

INSTITUT DE RECHERCHE MATHÉMATIQUE AVANCÉE
Université Louis Pasteur et CNRS (UMR 7501)
7, rue René Descartes
67084 Strasbourg Cedex

ALGÈBRES DE HOPF GRADUÉES
ET FIBRÉS PLATS SUR LES 3-VARIÉTÉS

par

ALEXIS VIRELIZIER

2000 Mathematics Subject Classification : 16W30, 16W50, 81R50, 57M27, 55R10, 57R56

Mots clés : algèbres de Hopf, groupes quantiques, variétés de dimension 3, fibrés principaux, topologie quantique

*Shoot for the moon. Even if you miss,
you'll land among the stars.*

LES BROWN

A mes parents

Remerciements

Je remercie chaleureusement mon directeur de thèse Vladimir Turaev qui a su me faire profiter de sa grande expérience en matière de recherche mathématique. Ses conseils ont toujours été une aide précieuse pour moi. J'ai beaucoup appris à son contact et eu grand plaisir à travailler avec lui.

Je remercie Christian Blanchet, Benjamin Enriquez, Christian Kassel et Marc Rosso pour avoir accepté de faire partie de mon jury de thèse et pour l'intérêt qu'ils ont porté à mon travail.

Je remercie également Léonid Vainerman avec qui j'ai eu de nombreuses discussions enrichissantes.

Je tiens à remercier tous ceux qui, à l'Université, ont participé à rendre ce travail possible et agréable. Je pense notamment à Marco, Alain et Véronique.

Je remercie enfin mes parents qui m'ont toujours affectueusement soutenu et Estelle qui, par sa présence et son amour, m'a accompagné tout au long de mes travaux.

Contents

Introduction	III
CHAPTER 1	
Hopf group-coalgebras	
1.1. Basic definitions	2
1.2. Modules and comodules	4
1.3. Existence and uniqueness of π -integrals	10
1.4. The distinguished π -grouplike element	13
1.5. Semisimplicity and cosemisimplicity	18
1.6. Involutory Hopf π -coalgebras	22
CHAPTER 2	
Quasitriangular Hopf group-coalgebras	
2.1. Quasitriangular Hopf π -coalgebras	25
2.2. Existence of π -traces	36
2.3. The case π finite: an abstract reformulation	39
2.4. Examples	42
CHAPTER 3	
Categorical Hopf group-algebras	
3.1. Basic facts on π -categories	45
3.2. Dinatural transformations and coends	51
3.3. Categorical Hopf π -algebras	55
3.4. Particular cases	59
CHAPTER 4	
Hennings-like invariants of group-links and group-manifolds	
4.1. Invariants of π -links	74
4.2. Invariants of π -manifolds	88
4.3. Comparison with the Turaev invariant	97
4.4. Homotopy quantum field theory	106
CHAPTER 5	
Kuperberg-like invariants of group-manifolds	
5.1. Invariants of π -colored Heegaard diagrams	121
5.2. Invariants of pointed π -manifolds	130
5.3. An example	135

Appendix A	137
Appendix B	143
Bibliography	147
Table of symbols	149
Index	151

Introduction

Depuis l'introduction d'un nouvel invariant polynômial des noeuds par Jones [14] en 1984, d'inattendus et spectaculaires liens entre la théorie purement algébrique des groupes quantiques et la topologie des noeuds et variétés de dimension 3 se sont révélés.

En 1989, Reshetikhin et Turaev [40] ont construit un invariant des variétés de dimension 3 (en les représentant par chirurgie le long d'entrelacs et en colorant ceux-ci à l'aide de représentations simples d'un groupe quantique), donnant ainsi une justification rigoureuse aux prédictions du physicien Witten [51]. Suivirent divers travaux permettant de calculer ces nouveaux invariants et mettant en évidence qu'ils s'étendent à une théorie topologique quantique des champs (TQFT) en dimension $2+1$, voir Kirby et Melvin [20], Lickorish [25, 26, 28], Blanchet, Habegger, Masbaum, Vogel [3, 4], Turaev [47], Kassel, Rosso, Turaev [16].

Durant cette période, d'autres invariants des variétés de dimension 3 furent construits, en particulier ceux de Hennings [12, 13] (définis directement à partir d'une algèbre de Hopf quasitriangulaire, c'est à dire sans utiliser ses représentations) et ceux de Kuperberg [21] (qui associe aux diagrammes de Heegaard d'une 3-variété un scalaire défini à partir des constantes de structure d'une algèbre de Hopf involutive).

Récemment, étant donné un groupe discret π , Turaev [48] a introduit la notion de π -catégorie modulaire et a montré qu'une telle catégorie permet la construction d'une théorie homotopique quantique des champs (HQFT) en dimension $2 + 1$ et, plus particulièrement, la construction d'invariants des π -fibrés principaux sur les 3-variétés. Le cas $\pi = 1$ est celui des invariants des 3-variétés définis dans [40, 47]. Des exemples de π -catégories sont les catégories de représentations de structures algébriques appelées π -cogèbres de Hopf, également introduites dans [48].

Le but de cette thèse est de développer, à partir d'une π -cogèbre de Hopf quasitriangulaire (resp. involutive), une théorie analogue à celle de Hennings (resp. de Kuperberg) dans le cadre des π -fibrés principaux sur les variétés de dimension 3.

La thèse est composée de deux parties. Dans la première (Chapitres 1 à 3), nous établissons les propriétés algébriques des π -cogèbres de Hopf nécessaires pour les constructions topologiques faites dans la seconde partie (Chapitres 4 et 5).

Fixons un groupe discret π et rappelons brièvement qu'une π -cogèbre de Hopf est une famille $H = \{H_\alpha\}_{\alpha \in \pi}$ d'algèbres (sur un corps \mathbb{k}) munie d'une comultiplication $\Delta = \{\Delta_{\alpha,\beta} : H_{\alpha\beta} \rightarrow H_\alpha \otimes H_\beta\}_{\alpha,\beta \in \pi}$, d'une counité $\varepsilon : H_1 \rightarrow \mathbb{k}$ et d'une antipode $S = \{S_\alpha : H_\alpha \rightarrow H_{\alpha^{-1}}\}_{\alpha \in \pi}$ qui vérifient certaines conditions de compatibilité. Le cas $\pi = 1$ est celui des algèbres de Hopf (en particulier H_1 est une algèbre de Hopf). Comme remarqué par Enriquez [9], quand le groupe π est fini, une π -cogèbre de Hopf peut être vue comme une *prolongation centrale* de l'algèbre de Hopf $F(\pi)$ des fonctions sur π , c'est à dire une algèbre de Hopf A munie d'un morphisme de Hopf $F(\pi) \rightarrow A$ dont l'image est centrale.

De nombreuses notions de la théorie des algèbres de Hopf peuvent s'étendre aux π -cogèbres de Hopf. En particulier, une π -intégrale (à droite) d'une π -cogèbre de Hopf $H = \{H_\alpha\}_{\alpha \in \pi}$ est une famille $\lambda = (\lambda_\alpha : H_\alpha \rightarrow \mathbb{k})_{\alpha \in \pi}$ de formes linéaires telles que $(\lambda_\alpha \otimes \text{id}_{H_\beta})\Delta_{\alpha,\beta} = \lambda_{\alpha\beta} 1_\beta$ pour tous $\alpha, \beta \in \pi$. Un *élément π -grouplike* de H est une famille $g = (g_\alpha)_{\alpha \in \pi} \in \prod_{\alpha \in \pi} H_\alpha$ telle que $\varepsilon(g_1) = 1$ et $\Delta_{\alpha,\beta}(g_{\alpha\beta}) = g_\alpha \otimes g_\beta$ pour tous $\alpha, \beta \in \pi$.

Dans le premier chapitre, nous nous intéressons principalement aux π -cogèbres de Hopf $H = \{H_\alpha\}_{\alpha \in \pi}$ de *type fini*, c'est à dire telles que chaque H_α soit de dimension finie. Un des résultats principaux de ce chapitre est l'existence et l'unicité (à multiplication scalaire près) des π -intégrales :

THÉORÈME 1.13. *L'espace des π -intégrales à droite (resp. à gauche) d'une π -cogèbre de Hopf de type fini est de dimension 1.*

Pour prouver ce résultat, nous étudions les modules π -gradués rationnels, nous introduisons la notion de π -comodule de Hopf et généralisons le théorème fondamental des modules de Hopf (affirmant qu'un module de Hopf est isomorphe au module de Hopf trivial associé à son sous-module des coinvariants, voir [24]) aux π -comodules de Hopf.

Comme pour les algèbres de Hopf, l'unicité des π -intégrales assure que toute π -cogèbre de Hopf $H = \{H_\alpha\}_{\alpha \in \pi}$ de type fini possède un élément π -grouplike, dit *distingué*, qui mesure le défaut d'une π -intégrale à droite de H à être une π -intégrale à gauche de H . Généralisant [39], nous établissons des relations entre l'élément π -grouplike distingué, l'antipode et les π -intégrales d'une π -cogèbre de Hopf de type fini (Théorème 1.16). Ces relations ont un rôle capital dans la construction de traces pour les π -cogèbres de Hopf (voir le Chapitre 2) et dans les constructions topologiques du Chapitre 4 (notamment de la théorie homotopique quantique des champs).

Nous montrons qu'une π -cogèbre de Hopf $H = \{H_\alpha\}_{\alpha \in \pi}$ de type fini est *semisimple* (c'est à dire chaque H_α est semisimple) si et seulement si H_1 est semisimple. Nous définissons la *cosemisimplicité* des π -comodules et des π -cogèbres, et nous utilisons les π -intégrales afin de donner des critères pour qu'une π -cogèbre de Hopf soit cosemisimple (Théorème 1.24). Ces critères nous permettent d'établir certaines propriétés concernant les π -cogèbres de Hopf de type fini et involutives (voir la Section 1.6) qui sont utilisées dans le Chapitre 5 pour généraliser les invariants de Kuperberg.

Dans le deuxième chapitre, nous étudions les π -cogèbres de Hopf quasitriangulaires et rubannées. Rappelons (voir [48]) qu'une π -cogèbre de Hopf $H = \{H_\alpha\}_{\alpha \in \pi}$ est dite *croisée* si elle est munie d'une famille $\varphi = \{\varphi_\beta : H_\alpha \rightarrow H_{\beta\alpha\beta^{-1}}\}_{\alpha, \beta \in \pi}$ d'isomorphismes d'algèbres, appelée *croisement*, qui préserve la comultiplication et la counité et qui définit une action de π , c'est à dire telle que $\varphi_\beta \varphi_{\beta'} = \varphi_{\beta\beta'}$. Une π -cogèbre de Hopf *quasitriangulaire* (resp. *rubannée*) est une π -cogèbre de Hopf croisée $H = \{H_\alpha\}_{\alpha \in \pi}$ munie d'une R -matrice $R = \{R_{\alpha, \beta} \in H_\alpha \otimes H_\beta\}_{\alpha, \beta \in \pi}$ (resp. d'une R -matrice et d'un twist $\theta = \{\theta_\alpha \in H_\alpha\}_{\alpha \in \pi}$) vérifiant des axiomes qui généralisent ceux donnés dans [7] (resp. [40]) et dans lesquels apparaît le croisement φ . Le cas $\pi = 1$ est celui des algèbres de Hopf. Quand π est abélien et φ est trivial, on retrouve la définition d'une algèbre de Hopf π -colorée quasitriangulaire (resp. rubannée) donnée par Ohtsuki [34].

La notion de trace pour une algèbre de Hopf s'étend aux π -cogèbres de Hopf croisées. Une π -trace d'une π -cogèbre de Hopf croisée $H = \{H_\alpha\}_{\alpha \in \pi}$ est une famille $\text{tr} = (\text{tr}_\alpha : H_\alpha \rightarrow \mathbb{k})_{\alpha \in \pi}$ de formes linéaires vérifiant $\text{tr}_\alpha(xy) = \text{tr}_\alpha(yx)$, $\text{tr}_{\alpha^{-1}}(S_\alpha(x)) = \text{tr}_\alpha(x)$ et $\text{tr}_{\beta\alpha\beta^{-1}}(\varphi_\beta(x)) = \text{tr}_\alpha(x)$ pour tous $\alpha, \beta \in \pi$ et $x, y \in H_\alpha$. Les π -cogèbres de Hopf rubannées munies d'une π -trace sont utilisées dans le Chapitre 4 pour généraliser les invariants de Hennings. Le résultat principal du deuxième chapitre est l'existence, sous certaines conditions techniques, de π -traces. Pour prouver ce résultat, nous généralisons les principales propriétés des algèbres de Hopf quasitriangulaires et rubannées (voir [8, 15, 38]). En particulier, étant donné une π -cogèbre de Hopf quasitriangulaire H , nous introduisons (à l'aide de la R -matrice et du croisement φ) les *éléments de Drinfeld* (généralisés) et nous montrons qu'ils permettent de calculer l'élément π -grouplike distingué de H (Théorème 2.7). Lorsque H est rubannée, le twist et les éléments de Drinfeld de H permettent la construction d'un élément π -grouplike $G = (G_\alpha)_{\alpha \in \pi}$ qui implémente le carré de l'antipode par conjugaison. Cet élément π -grouplike, les π -intégrales et leurs relations avec l'élément π -grouplike distingué sont à la base de la construction des π -traces. Par exemple, nous obtenons :

THÉORÈME 2.14. *Soit $H = \{H_\alpha\}_{\alpha \in \pi}$ une π -cogèbre de Hopf rubannée, de type fini et unimodulaire (c'est à dire l'algèbre de Hopf H_1 est unimodulaire). Soit $(\lambda_\alpha)_{\alpha \in \pi}$ une π -intégrale à droite de H . Si H est semisimple ou cosemisimple, alors $(x \in H_\alpha \mapsto \lambda_\alpha(G_\alpha x) \in \mathbb{k})_{\alpha \in \pi}$ est une π -trace de H .*

Quand le groupe π est fini, les définitions et résultats principaux concernant les π -cogèbres de Hopf quasitriangulaires et rubannées peuvent être réécrits, de manière intrinsèque, dans le langage des prolongations centrales de l'algèbre de Hopf des fonctions sur π .

Les deux premiers chapitres ont fait l'objet d'un article [50].

Dans le troisième chapitre, nous introduisons et étudions les π -algèbres de Hopf catégorielles qui jouent un rôle important dans la partie topologique (voir Section 4.3). Une π -algèbre de Hopf dans une catégorie tressée est une famille $A = \{A_\alpha\}_{\alpha \in \pi}$ d'objets munie de morphismes de structure qui vérifient des axiomes duaux à ceux d'une π -cogèbre de Hopf. En utilisant la propriété universelle de factorisation des coends, nous construisons explicitement une π -algèbre de Hopf catégorielle $A = \{A_\alpha\}_{\alpha \in \pi}$ dans la composante neutre de chaque π -catégorie rubannée (Théorème 3.5). Lorsque $\pi = 1$, nous retrouvons les algèbres de Hopf catégorielles de Lyubashenko [30]. Lorsque la π -catégorie est celle des représentations d'une π -cogèbre de Hopf rubannée $H = \{H_\alpha\}_{\alpha \in \pi}$ de type fini et unimodulaire, nous relient les intégrales de A et H (ce résultat est un des points clé de la démonstration du Théorème 4.18) :

THÉORÈME 3.8. *Les π -intégrales catégorielles de A sont en bijection canonique avec les π -intégrales de H .*

La deuxième partie de la thèse est consacrée à la généralisation des invariants de Hennings (Chapitre 4) et de Kuperberg (Chapitre 5) à des invariants des fibrés principaux plats sur les variétés de dimension 3. Fixons un groupe discret π (l'étude des fibrés principaux plats se ramène à celle des fibrés principaux dont la fibre est discrète).

Rappelons qu'Hennings [12, 13] a défini un invariant des noeuds et des 3-variétés en termes d'intégrales sur certaines algèbres de Hopf. Kauffman et Radford [17] ont clarifié les rapports entre cet invariant et les algèbres de Hopf et ont simplifié la construction d'Hennings. Dans le quatrième chapitre, partant d'une π -cogèbre de Hopf rubannée $H = \{H_\alpha\}_{\alpha \in \pi}$ munie d'une π -trace $\text{tr} = (\text{tr}_\alpha)_{\alpha \in \pi}$, nous donnons une version améliorée de la méthode de Kauffman-Radford pour construire un invariant $\text{Inv}_{\{H, \text{tr}\}}(L, g)$ des paires (L, g) , où L est un entrelacs parallélisé et $g : \pi_1(S^3 \setminus L) \rightarrow \pi$ est un morphisme de groupe (Théorème 4.3). Cette construction s'effectue en colorant les segments verticaux d'un diagramme générique de L par π via le morphisme g , en décorant les croisements du diagramme ainsi π -coloré avec la R -matrice $R = \{R_{\alpha, \beta}\}_{\alpha, \beta \in \pi}$, en concentrant les éléments algébriques de cette décoration, grâce aux morphismes de structure de H , puis en les évaluant avec la π -trace $\text{tr} = (\text{tr}_\alpha)_{\alpha \in \pi}$. La preuve du Théorème 4.3 consiste à montrer que les mouvements de Reidemeister colorés rendent compte de l'équivalence des paires (L, g) , puis à vérifier l'invariance par rapport à ces mouvements en utilisant les propriétés des π -cogèbres de Hopf quasitriangulaires et rubannées et de leurs π -traces établies dans le Chapitre 2 (en particulier les Lemmes 2.4, 2.5 et 2.9).

Nous donnons des exemples de calculs (faits à l'aide de π -cogèbres de Hopf construites à partir de bicaractères de π) montrant que l'invariant $\text{Inv}_{\{H, \text{tr}\}}$ est non trivial.

Lorsqu'une π -trace tr^λ construite à partir d'une π -intégrale λ est utilisée, l'invariant $\text{Inv}_{\{H, \text{tr}^\lambda\}}$ peut être normalisé en un invariant $\tau_H(M, \xi)$ des π -fibrés principaux ξ au dessus des 3-variétés M . Cette construction s'effectue en présentant l'espace de base M par chirurgie le long d'un entrelacs parallélisé L , en définissant $g : \pi_1(S^3 \setminus L) \rightarrow \pi$ à l'aide de la monodromie du π -fibré, puis en normalisant l'invariant $\text{Inv}_{\{H, \text{tr}^\lambda\}}(L, g)$.

THÉORÈME 4.12. *Si $H = \{H_\alpha\}_{\alpha \in \pi}$ est une π -cogèbre de Hopf rubannée, unimodulaire et de type fini, alors τ_H est un invariant des π -fibrés principaux sur les variétés de dimension 3.*

Pour prouver ce résultat, nous montrons que les mouvements de Kirby colorés rendent compte de l'équivalence des π -fibrés principaux sur les 3-variétés, puis nous vérifions l'invariance par rapport à ces mouvements grâce aux propriétés des π -intégrales (en particulier le Théorème 1.16), sachant que nous utilisons une π -trace construite à partir d'une π -intégrale.

L'invariant τ_H est non trivial (nous donnons un exemple de calcul pour des $\mathbb{Z}/n\mathbb{Z}$ -fibrés sur certains espaces lenticulaires en utilisant les $\mathbb{Z}/n\mathbb{Z}$ -cogèbres de Hopf décrites dans [34]) et coïncide avec celui de Hennings lorsque $\pi = 1$.

Rappelons que Turaev [48] a construit un invariant \mathcal{T}_C des π -fibrés principaux sur les 3-variétés à partir d'une π -catégorie modulaire C . En général, la catégorie des représentations $\text{Rep}(H)$ d'une π -cogèbre de Hopf rubannée, unimodulaire et de type fini H n'est pas modulaire, mais elle permet souvent la construction d'une catégorie C_H modulaire (voir [5]). Dans ce cas, les invariants τ_H et \mathcal{T}_{C_H} sont en général différents (voir [17] pour le cas $\pi = 1$). Cependant, nous obtenons :

THÉORÈME 4.18. *Si $\text{Rep}(H)$ est modulaire, les invariants τ_H et $\mathcal{T}_{\text{Rep}(H)}$ coïncident.*

La technique employée pour montrer ce résultat, esquissée dans [18, 29] pour le cas $\pi = 1$, utilise les π -algèbres de Hopf catégorielles étudiées dans le Chapitre 3 (en particulier les Théorèmes 3.5 et 3.8) qui permettent de relier l'approche catégorielle de [48] avec celle algébrique développée ici. Plus précisément, la comparaison s'effectue en réécrivant l'invariant de Turaev à l'aide des π -intégrales d'une π -algèbre de Hopf catégorielle de $\text{Rep}(H)$ qui est explicitée au moyen des morphismes de structures de H .

Rappelons brièvement qu'une théorie homotopique quantique des champs en dimension $2 + 1$ ayant pour but un espace X peut être vue comme une théorie topologique quantique des champs pour les surfaces et les 3-cobordismes munis d'une classe d'homotopie d'applications vers X . De même qu'une théorie topologique quantique des champs donne naissance à des invariants des variétés de dimension 3, une théorie homotopique quantique des champs ayant pour but l'espace d'Eilenberg-Mac Lane $K(\pi, 1)$ donne naissance à des invariants des π -fibrés principaux sur les variétés de dimension 3.

THÉORÈME 4.27. *Sous les hypothèses du Théorème 4.12, l'invariant τ_H s'étend à une théorie homotopique quantique des champs en dimension $2 + 1$ (pour surfaces connexes) ayant pour but l'espace d'Eilenberg-Mac Lane $K(\pi, 1)$.*

Dans [21], Kuperberg a construit, à l'aide d'une algèbre de Hopf involutive, un invariant des 3-variétés en les présentant par des diagrammes de Heegaard. Le résultat principal du cinquième chapitre est la généralisation de cette construction au cadre des π -fibrés principaux sur les variétés de dimension 3. Elle s'effectue en présentant l'espace de base d'un π -fibré principal sur une 3-variété par un diagramme de Heegaard que l'on colore par π grâce à la monodromie du fibré et auquel on associe des constantes de structures d'une π -cogèbre de Hopf involutive.

THÉORÈME 5.5. *Toute π -cogèbre de Hopf $H = \{H_\alpha\}_{\alpha \in \pi}$ qui est involutive, de type fini, et telle que $\dim H_1 \neq 0$ (dans le corps de base \mathbb{k}), permet la construction d'un invariant K_H des π -fibrés principaux sur les variétés de dimension 3.*

Pour prouver ce résultat, nous montrons que les mouvements de Reidemeister-Singer colorés rendent compte de l'équivalence des π -fibrés principaux sur les 3-variétés, puis nous vérifions l'invariance par rapport à ces mouvements en utilisant les propriétés des π -cogèbres de Hopf involutives (voir en particulier la Section 1.6 et les Lemmes 5.1 et 5.2).

L'invariant K_H est non trivial (nous donnons des exemples de calculs pour des $\mathbb{Z}/2\mathbb{Z}$ -fibrés sur certains espaces lenticulaires en utilisant une $\mathbb{Z}/2\mathbb{Z}$ -cogèbre de Hopf involutive [49] dérivée de l'algèbre de Hopf de Kac-Paljutkin) et coïncide avec celui de Kuperberg lorsque $\pi = 1$.

Cette thèse est organisée de la manière suivante. Le Chapitre 1 est consacré à l'étude des π -cogèbres de Hopf et le Chapitre 2 à celle des π -cogèbres de Hopf quasitriangulaires. Dans le Chapitre 3, nous étudions les π -algèbres de Hopf catégorielles. Le Chapitre 4 est consacré à la généralisation des invariants de Hennings et le Chapitre 5 à celle des invariants de Kuperberg. Dans l'Annexe A, nous étudions les $\mathbb{Z}/n\mathbb{Z}$ -cogèbres de Hopf de [34]. Finalement, dans l'Annexe B, nous calculons la valeur de certains invariants en utilisant la $\mathbb{Z}/2\mathbb{Z}$ -cogèbre de Hopf involutive de [49].

CHAPTER 1

Hopf group-coalgebras

The notion of a Hopf group-coalgebra, introduced in [48], generalizes that of a Hopf algebra. We will use Hopf group-coalgebras to construct Hennings-like (see Chapter 4) and Kuperberg-like (see Chapter 5) invariants of flat bundles over 3-manifolds. The aim of the present chapter (together with the following) is to lay the algebraic foundations needed for these topological purposes.

Given a (discrete) group π , a Hopf π -coalgebra is a family $H = \{H_\alpha\}_{\alpha \in \pi}$ of algebras (over a field \mathbb{k}) endowed with a comultiplication $\Delta = \{\Delta_{\alpha,\beta} : H_{\alpha\beta} \rightarrow H_\alpha \otimes H_\beta\}_{\alpha,\beta \in \pi}$, a counit $\varepsilon : H_1 \rightarrow \mathbb{k}$, and an antipode $S = \{S_\alpha : H_\alpha \rightarrow H_{\alpha^{-1}}\}_{\alpha \in \pi}$ which verify some compatibility conditions. Basic notions of the theory of Hopf algebras can be extended to the setting of Hopf π -coalgebras. In particular, a (right) π -integral for a Hopf π -coalgebra H is a family of \mathbb{k} -forms $\lambda = (\lambda_\alpha : H_\alpha \rightarrow \mathbb{k})_{\alpha \in \pi}$ such that $(\lambda_\alpha \otimes \text{id}_{H_\beta})\Delta_{\alpha,\beta} = \lambda_{\alpha\beta} 1_\beta$ for all $\alpha, \beta \in \pi$.

In this chapter, we mainly focus on Hopf π -coalgebras of finite type, that is Hopf π -coalgebras $H = \{H_\alpha\}_{\alpha \in \pi}$ with each H_α finite-dimensional. The first main result is the existence and uniqueness (up to a scalar multiple) of a π -integral for such a Hopf π -coalgebra. To prove this result, we study rational π -graded modules, introduce the notion of a Hopf π -comodule, and generalize the fundamental theorem of Hopf modules (saying that a Hopf module is isomorphic to the trivial module associated to its submodule of coinvariants, see [24]) to Hopf π -comodules.

As for Hopf algebras, the uniqueness of the π -integrals assures that any finite type Hopf π -coalgebra contains a π -grouplike element, called distinguished, which measures the defect of a right π -integral to be a left π -integral. Generalizing [39], we study the relationships between this element, the antipode, and the π -integrals. As a corollary, we give an upper bound for the order of $S_{\alpha^{-1}}S_\alpha$ whenever $\alpha \in \pi$ has a finite order.

The notions of semisimplicity and cosemisimplicity can be extended to the setting of Hopf π -coalgebras. We show that a finite type Hopf π -coalgebra $H = \{H_\alpha\}_{\alpha \in \pi}$ is semisimple (that is each H_α is semisimple) if and only if H_1 is semisimple. We define the cosemisimplicity for π -comodules and π -coalgebras, and we use π -integrals to give necessary and sufficient criteria for a Hopf π -coalgebra to be cosemisimple.

When the ground field \mathbb{k} is of characteristic zero, a Hopf π -coalgebra $H = \{H_\alpha\}_{\alpha \in \pi}$ which is involutory (that is $S_{\alpha^{-1}}S_\alpha = \text{id}_{H_\alpha}$ for all $\alpha \in \pi$) is semisimple and cosemisimple and verifies that $\dim H_\alpha = \dim H_1$ whenever $H_\alpha \neq 0$.

This chapter is organized as follows. In Section 1.1, we review the basic definitions and properties of Hopf π -coalgebras. In Section 1.2, we discuss the notions of a rational π -graded module and of a Hopf π -comodule. In Section 1.3, we use these notions to establish the existence and uniqueness of π -integrals. Section 1.4 is devoted to the study of the distinguished π -grouplike element. In Section 1.5, we discuss the notion of a semisimple (resp. cosemisimple) Hopf π -coalgebra. Finally, in Section 1.6, we study involutory Hopf π -coalgebras.

1.1. Basic definitions

Throughout this thesis, we let π be a discrete group (with neutral element 1) and \mathbb{k} be a field (although much of what we do is valid over any commutative ring). We set $\mathbb{k}^* = \mathbb{k} \setminus \{0\}$. All algebras are supposed to be over \mathbb{k} , associative, and unitary. The tensor product $\otimes = \otimes_{\mathbb{k}}$ is always assumed to be over \mathbb{k} . If U and V are \mathbb{k} -spaces, $\sigma_{U,V} : U \otimes V \rightarrow V \otimes U$ will denote the flip map defined by $\sigma_{U,V}(u \otimes v) = v \otimes u$ for all $u \in U$ and $v \in V$.

1.1.1. π -coalgebras. We recall the definition of a π -coalgebra, following [48, §11.2]. A π -coalgebra (over \mathbb{k}) is a family $C = \{C_\alpha\}_{\alpha \in \pi}$ of \mathbb{k} -spaces endowed with a family $\Delta = \{\Delta_{\alpha,\beta} : C_{\alpha\beta} \rightarrow C_\alpha \otimes C_\beta\}_{\alpha,\beta \in \pi}$ of \mathbb{k} -linear maps (the *comultiplication*) and a \mathbb{k} -linear map $\varepsilon : C_1 \rightarrow \mathbb{k}$ (the *counit*) such that

(1.1) Δ is coassociative in the sense that, for any $\alpha, \beta, \gamma \in \pi$,

$$(\Delta_{\alpha,\beta} \otimes \text{id}_{C_\gamma})\Delta_{\alpha\beta,\gamma} = (\text{id}_{C_\alpha} \otimes \Delta_{\beta,\gamma})\Delta_{\alpha,\beta\gamma};$$

(1.2) for all $\alpha \in \pi$, $(\text{id}_{C_\alpha} \otimes \varepsilon)\Delta_{\alpha,1} = \text{id}_{C_\alpha} = (\varepsilon \otimes \text{id}_{C_\alpha})\Delta_{1,\alpha}$.

Note that $(C_1, \Delta_{1,1}, \varepsilon)$ is a coalgebra in the usual sense of the word.

Sweedler's notation. We extend the Sweedler notation for a comultiplication in the following way: for any $\alpha, \beta \in \pi$ and $c \in C_{\alpha\beta}$, we write

$$\Delta_{\alpha,\beta}(c) = \sum_{(c)} c_{(1,\alpha)} \otimes c_{(2,\beta)} \in C_\alpha \otimes C_\beta,$$

or shortly, if we leave the summation implicit, $\Delta_{\alpha,\beta}(c) = c_{(1,\alpha)} \otimes c_{(2,\beta)}$.

The coassociativity axiom (1.1) gives that, for any $\alpha, \beta, \gamma \in \pi$ and $c \in C_{\alpha\beta\gamma}$,

$$c_{(1,\alpha\beta)(1,\alpha)} \otimes c_{(1,\alpha\beta)(2,\beta)} \otimes c_{(2,\gamma)} = c_{(1,\alpha)} \otimes c_{(2,\beta\gamma)(1,\beta)} \otimes c_{(2,\beta\gamma)(2,\gamma)}.$$

This element of $C_\alpha \otimes C_\beta \otimes C_\gamma$ is written as $c_{(1,\alpha)} \otimes c_{(2,\beta)} \otimes c_{(3,\gamma)}$. By iterating the procedure, we define inductively $c_{(1,\alpha_1)} \otimes \cdots \otimes c_{(n,\alpha_n)}$ for any $c \in C_{\alpha_1 \cdots \alpha_n}$.

1.1.2. Convolution algebras. Let $C = (\{C_\alpha\}, \Delta, \varepsilon)$ be a π -coalgebra and A be an algebra with multiplication m and unit element 1_A . For any $f \in \text{Hom}_{\mathbb{k}}(C_\alpha, A)$ and $g \in \text{Hom}_{\mathbb{k}}(C_\beta, A)$, we define their *convolution product* by

$$f * g = m(f \otimes g)\Delta_{\alpha,\beta} \in \text{Hom}_{\mathbb{k}}(C_{\alpha\beta}, A).$$

Using (1.1) and (1.2), one verifies that the \mathbb{k} -space

$$\text{Conv}(C, A) = \bigoplus_{\alpha \in \pi} \text{Hom}_{\mathbb{k}}(C_\alpha, A),$$

endowed with the convolution product $*$ and the unit element $\varepsilon 1_A$, is a π -graded algebra, called *convolution algebra*.

In particular, for $A = \mathbb{k}$, the π -graded algebra $\text{Conv}(C, \mathbb{k}) = \bigoplus_{\alpha \in \pi} C_\alpha^*$ is called *dual* to C and is denoted by C^* .

1.1.3. Hopf π -coalgebras. Following [48, §11.2], a *Hopf π -coalgebra* is a π -coalgebra $H = (\{H_\alpha\}, \Delta, \varepsilon)$ endowed with a family $S = \{S_\alpha : H_\alpha \rightarrow H_{\alpha^{-1}}\}_{\alpha \in \pi}$ of \mathbb{k} -linear maps (the *antipode*) such that

(1.3) each H_α is an algebra with multiplication m_α and unit element $1_\alpha \in H_\alpha$;

(1.4) $\varepsilon : H_1 \rightarrow \mathbb{k}$ and $\Delta_{\alpha,\beta} : H_{\alpha\beta} \rightarrow H_\alpha \otimes H_\beta$ (for all $\alpha, \beta \in \pi$) are algebra homomorphisms;

(1.5) for any $\alpha \in \pi$,

$$m_\alpha(S_{\alpha^{-1}} \otimes \text{id}_{H_\alpha})\Delta_{\alpha^{-1},\alpha} = \varepsilon 1_\alpha = m_\alpha(\text{id}_{H_\alpha} \otimes S_{\alpha^{-1}})\Delta_{\alpha,\alpha^{-1}}.$$

We remark that the notion of a Hopf π -coalgebra is not self-dual and that $(H_1, m_1, 1_1, \Delta_{1,1}, \varepsilon, S_1)$ is a (classical) Hopf algebra.

The Hopf π -coalgebra H is said to be of *finite type* if, for all $\alpha \in \pi$, H_α is finite-dimensional (over \mathbb{k}). Note that it does not mean that $\bigoplus_{\alpha \in \pi} H_\alpha$ is finite-dimensional (unless $H_\alpha = 0$ for all but a finite number of $\alpha \in \pi$).

The antipode $S = \{S_\alpha\}_{\alpha \in \pi}$ of H is said to be *bijective* if each S_α is bijective. Unlike [48, §11.2], we do not suppose that the antipode of a Hopf π -coalgebra H is bijective. However, we will show that it is bijective whenever H is of finite type (see Corollary 1.14(a)) or quasitriangular (see Lemma 2.5(c)).

A useful remark is that if $H = \{H_\alpha\}_{\alpha \in \pi}$ is a Hopf π -coalgebra with antipode $S = \{S_\alpha\}_{\alpha \in \pi}$, then Axiom (1.5) says that S_α is the inverse of $\text{id}_{H_{\alpha^{-1}}}$ in the convolution algebra $\text{Conv}(H, H_{\alpha^{-1}})$ for all $\alpha \in \pi$.

In the next lemma, generalizing [45, PROPOSITION 4.0.1], we show that the antipode of a Hopf π -coalgebra is anti-multiplicative and anti-comultiplicative.

LEMMA 1.1. *Let $H = (\{H_\alpha, m_\alpha, 1_\alpha\}, \Delta, \varepsilon, S)$ be a Hopf π -coalgebra. Then*

- (a) $S_\alpha(ab) = S_\alpha(b)S_\alpha(a)$ for any $\alpha \in \pi$ and $a, b \in H_\alpha$;
- (b) $S_\alpha(1_\alpha) = 1_{\alpha^{-1}}$ for any $\alpha \in \pi$;
- (c) $\Delta_{\beta^{-1}, \alpha^{-1}} S_{\alpha\beta} = \sigma_{H_{\alpha^{-1}}, H_{\beta^{-1}}}(S_\alpha \otimes S_\beta) \Delta_{\alpha, \beta}$ for any $\alpha, \beta \in \pi$;
- (d) $\varepsilon S_1 = \varepsilon$.

Proof. The proof is essentially the same as in the Hopf algebra setting. For example, to show Part (c), fix $\alpha, \beta \in \pi$ and consider the algebra $\text{Conv}(H, H_{\beta^{-1}} \otimes H_{\alpha^{-1}})$ with convolution product $*$ and unit element $e = \varepsilon 1_{\beta^{-1}} \otimes 1_{\alpha^{-1}}$. Using Axioms (1.2), (1.4), and (1.5), one easily checks that $\Delta_{\beta^{-1}, \alpha^{-1}} S_{\alpha\beta} * \Delta_{\beta^{-1}, \alpha^{-1}} = e$ and $\Delta_{\beta^{-1}, \alpha^{-1}} * \sigma_{H_{\alpha^{-1}}, H_{\beta^{-1}}}(S_\alpha \otimes S_\beta) \Delta_{\alpha, \beta} = e$. Hence we can conclude that $\Delta_{\beta^{-1}, \alpha^{-1}} S_{\alpha\beta} = \sigma_{H_{\alpha^{-1}}, H_{\beta^{-1}}}(S_\alpha \otimes S_\beta) \Delta_{\alpha, \beta}$. \square

COROLLARY 1.2. *Let $H = \{H_\alpha\}_{\alpha \in \pi}$ be a Hopf π -coalgebra. Then $\{\alpha \in \pi \mid H_\alpha \neq 0\}$ is a subgroup of π .*

Proof. Set $G = \{\alpha \in \pi \mid H_\alpha \neq 0\}$. Firstly $1_1 \neq 0$ (since $\varepsilon(1_1) = 1_{\mathbb{k}} \neq 0$) and so $1 \in G$. Then let $\alpha, \beta \in G$. Using (1.4), $\Delta_{\alpha, \beta}(1_{\alpha\beta}) = 1_\alpha \otimes 1_\beta \neq 0$. Therefore $1_{\alpha\beta} \neq 0$ and so $\alpha\beta \in G$. Finally, let $\alpha \in G$. By Lemma 1.1(b), $S_{\alpha^{-1}}(1_{\alpha^{-1}}) = 1_\alpha \neq 0$. Thus $1_{\alpha^{-1}} \neq 0$ and hence $\alpha^{-1} \in G$. \square

1.1.3.1. Opposite Hopf π -coalgebra. Let $H = \{H_\alpha\}_{\alpha \in \pi}$ be a Hopf π -coalgebra. Suppose that the antipode $S = \{S_\alpha\}_{\alpha \in \pi}$ of H is bijective. For any $\alpha \in \pi$, let H_α^{op} be the opposite algebra to H_α . Then $H^{\text{op}} = \{H_\alpha^{\text{op}}\}_{\alpha \in \pi}$, endowed with the comultiplication and counit of H and with the antipode $S^{\text{op}} = \{S_\alpha^{\text{op}} = S_{\alpha^{-1}}^{-1}\}_{\alpha \in \pi}$, is a Hopf π -coalgebra, called *opposite to H* .

1.1.3.2. Coopposite Hopf π -coalgebra. Let $C = (\{C_\alpha\}, \Delta, \varepsilon)$ be a π -coalgebra. Set

$$C_\alpha^{\text{cop}} = C_{\alpha^{-1}} \quad \text{and} \quad \Delta_{\alpha, \beta}^{\text{cop}} = \sigma_{C_{\beta^{-1}}, C_{\alpha^{-1}}} \Delta_{\beta^{-1}, \alpha^{-1}}.$$

Then $C^{\text{cop}} = (\{C_\alpha^{\text{cop}}\}, \Delta^{\text{cop}}, \varepsilon)$ is a π -coalgebra, called *coopposite to C* . If H is a Hopf π -coalgebra whose antipode $S = \{S_\alpha\}_{\alpha \in \pi}$ is bijective, then the coopposite π -coalgebra H^{cop} , where $H_\alpha^{\text{cop}} = H_{\alpha^{-1}}$ as an algebra, is a Hopf π -coalgebra with antipode $S^{\text{cop}} = \{S_\alpha^{\text{cop}} = S_{\alpha^{-1}}^{-1}\}_{\alpha \in \pi}$.

1.1.3.3. Opposite and coopposite Hopf π -coalgebra. Let $H = (\{H_\alpha\}, \Delta, \varepsilon, S)$ be a Hopf π -coalgebra. Even if the antipode of H is not bijective, one can always define a Hopf π -coalgebra *opposite and coopposite to H* by setting $H_\alpha^{\text{op, cop}} = H_{\alpha^{-1}}^{\text{op}}$, $\Delta_{\alpha, \beta}^{\text{op, cop}} = \Delta_{\alpha, \beta}^{\text{cop}}$, $\varepsilon^{\text{op, cop}} = \varepsilon$, and $S_\alpha^{\text{op, cop}} = S_{\alpha^{-1}}$.

1.1.3.4. The dual Hopf algebra. Let $H = (\{H_\alpha, m_\alpha, 1_\alpha\}, \Delta, \varepsilon, S)$ be a finite type Hopf π -coalgebra. The π -graded algebra $H^* = \bigoplus_{\alpha \in \pi} H_\alpha^*$ dual to H (see §1.1.2) inherits a structure of a Hopf algebra by setting, for all $\alpha \in \pi$ and $f \in H_\alpha^*$,

$$\Delta(f) = m_\alpha^*(f) \in (H_\alpha \otimes H_\alpha)^* \cong H_\alpha^* \otimes H_\alpha^*,$$

$\varepsilon(f) = f(1_\alpha)$, and $S(f) = f \circ S_{\alpha^{-1}}$. Note that if $H_\alpha \neq 0$ for infinitely many $\alpha \in \pi$, then H^* is infinite-dimensional.

1.1.3.5. The case π finite. Let us first remark that, when π is a finite group, there is a one-to-one correspondence between (isomorphic classes of) π -coalgebras and (isomorphic classes of) π -graded coalgebras. Recall that a coalgebra (C, Δ, ε) is π -graded if C admits a decomposition as a direct sum of \mathbb{k} -spaces $C = \bigoplus_{\alpha \in \pi} C_\alpha$ such that, for any $\alpha \in \pi$,

$$\Delta(C_\alpha) \subseteq \sum_{\beta\gamma=\alpha} C_\beta \otimes C_\gamma \quad \text{and} \quad \varepsilon(C_\alpha) = 0 \text{ if } \alpha \neq 1.$$

Let us denote by $p_\alpha : C \rightarrow C_\alpha$ the canonical projection. Then $\{C_\alpha\}_{\alpha \in \pi}$ is a π -coalgebra with comultiplication $\{(p_\alpha \otimes p_\beta)\Delta|_{C_{\alpha\beta}}\}_{\alpha, \beta \in \pi}$ and counit $\varepsilon|_{C_1}$. Conversely, if $C = (\{C_\alpha\}, \Delta, \varepsilon)$ is a π -coalgebra, then $\tilde{C} = \bigoplus_{\alpha \in \pi} C_\alpha$ is a π -graded coalgebra with comultiplication $\tilde{\Delta}$ and counit $\tilde{\varepsilon}$ given on the summands by

$$\tilde{\Delta}|_{C_\alpha} = \sum_{\beta\gamma=\alpha} \Delta_{\beta,\gamma} \quad \text{and} \quad \tilde{\varepsilon}|_{C_\alpha} = \begin{cases} \varepsilon & \text{if } \alpha = 1 \\ 0 & \text{if } \alpha \neq 1 \end{cases}.$$

Let now $H = (\{H_\alpha, m_\alpha, 1_\alpha\}, \Delta, \varepsilon, S)$ be a Hopf π -coalgebra, where π is a finite group. Then the coalgebra $(\tilde{H}, \tilde{\Delta}, \tilde{\varepsilon})$, defined as above, is a Hopf algebra with multiplication \tilde{m} , unit element $\tilde{1}$, and antipode \tilde{S} given by

$$\tilde{m}|_{H_\alpha \otimes H_\beta} = \begin{cases} m_\alpha & \text{if } \alpha = \beta \\ 0 & \text{if } \alpha \neq \beta \end{cases}, \quad \tilde{1} = \sum_{\alpha \in \pi} 1_\alpha, \quad \text{and} \quad \tilde{S} = \sum_{\alpha \in \pi} S_\alpha.$$

When H is of finite type and π is finite, the Hopf algebra H^* (see §1.1.3.4) is simply the dual Hopf algebra \tilde{H}^* .

Note that if π is a finite group, then the notion of a Hopf π -coalgebra coincides with that of a central prolongation of the Hopf algebra of functions on π (see Section 2.3.1).

REMARK. When π is finite, the structure of π -comodules over a π -coalgebra $C = \{C_\alpha\}_{\alpha \in \pi}$ (Theorem 1.4), the existence of π -integrals for a finite type Hopf π -coalgebra $H = \{H_\alpha\}_{\alpha \in \pi}$ (Theorem 1.13) and their relations with the distinguished π -grouplike element (Theorem 1.16) can be deduced from the classical theory of coalgebras and Hopf algebras by using $\tilde{C} = \bigoplus_{\alpha \in \pi} C_\alpha$ or $\tilde{H} = \bigoplus_{\alpha \in \pi} H_\alpha$ (defined as in §1.1.3.5). Nevertheless, for the general case, self-contained proofs must be given.

In general, the results relating to a quasitriangular Hopf π -coalgebra (see Sect. 2.1-2.2) cannot be deduced from the classical theory of quasitriangular Hopf algebras, even if π is finite. Indeed, an R -matrix for a Hopf π -coalgebra H (whose definition involves an action of π , see §2.1.2) does not necessarily lead to a usual R -matrix for the Hopf algebra \tilde{H} .

1.2. Modules and comodules

In this section, we introduce and discuss the notions of π -comodules, rational π -graded modules, and Hopf π -comodules. They are used in Section 1.3 to show the existence of integrals.

1.2.1. π -comodules. Let $C = (\{C_\alpha\}, \Delta, \varepsilon)$ be a π -coalgebra. A *right π -comodule over C* is a family $M = \{M_\alpha\}_{\alpha \in \pi}$ of \mathbb{k} -spaces endowed with a family $\rho = \{\rho_{\alpha,\beta} : M_{\alpha\beta} \rightarrow M_\alpha \otimes C_\beta\}_{\alpha,\beta \in \pi}$ of \mathbb{k} -linear maps (the *structure maps*) such that

$$(1.6) \quad \text{for any } \alpha, \beta, \gamma \in \pi,$$

$$(\rho_{\alpha,\beta} \otimes \text{id}_{C_\gamma})\rho_{\alpha\beta,\gamma} = (\text{id}_{M_\alpha} \otimes \Delta_{\beta,\gamma})\rho_{\alpha,\beta\gamma};$$

$$(1.7) \quad \text{for any } \alpha \in \pi, (\text{id}_{M_\alpha} \otimes \varepsilon)\rho_{\alpha,1} = \text{id}_{M_\alpha}.$$

Note that M_1 endowed with the structure map $\rho_{1,1}$ is a (usual) right comodule over the coalgebra C_1 .

If π is finite and $\tilde{C} = \bigoplus_{\alpha \in \pi} C_\alpha$ is the π -graded coalgebra defined as in §1.1.3.5, then M leads to a π -graded right comodule $\tilde{M} = \bigoplus_{\alpha \in \pi} M_\alpha$ over \tilde{C} with comodule map $\tilde{\rho} = \sum_{\alpha,\beta \in \pi} \rho_{\alpha,\beta}$ (see [32]).

A π -subcomodule of M is a family $N = \{N_\alpha\}_{\alpha \in \pi}$, where N_α is a \mathbb{k} -subspace of M_α , such that $\rho_{\alpha,\beta}(N_{\alpha\beta}) \subset N_\alpha \otimes C_\beta$ for all $\alpha, \beta \in \pi$. Then N is a right π -comodule over C with induced structure maps.

A π -comodule morphism between two right π -comodules M and M' over C (with structure maps ρ and ρ') is a family $f = \{f_\alpha : M_\alpha \rightarrow M'_\alpha\}_{\alpha \in \pi}$ of \mathbb{k} -linear maps such that $\rho'_{\alpha,\beta} f_{\alpha\beta} = (f_\alpha \otimes \text{id}_{C_\beta})\rho_{\alpha,\beta}$ for all $\alpha, \beta \in \pi$.

Sweedler's notation. We extend the notation of Section 1.1.1 by setting, for any $\alpha, \beta \in \pi$ and $m \in M_{\alpha\beta}$,

$$\rho_{\alpha,\beta}(m) = m_{(0,\alpha)} \otimes m_{(1,\beta)} \in M_\alpha \otimes C_\beta.$$

Axiom (1.6) gives that, for any $\alpha, \beta, \gamma \in \pi$ and $m \in M_{\alpha\beta\gamma}$,

$$m_{(0,\alpha\beta)(0,\alpha)} \otimes m_{(0,\alpha\beta)(1,\beta)} \otimes m_{(1,\gamma)} = m_{(0,\alpha)} \otimes m_{(1,\beta\gamma)(1,\beta)} \otimes m_{(1,\beta\gamma)(2,\gamma)}.$$

This element of $M_\alpha \otimes C_\beta \otimes C_\gamma$ is written as $m_{(0,\alpha)} \otimes m_{(1,\beta)} \otimes m_{(2,\gamma)}$. By iterating the procedure, we define inductively $m_{(0,\alpha_0)} \otimes m_{(1,\alpha_1)} \otimes \cdots \otimes m_{(n,\alpha_n)}$ for any $m \in M_{\alpha_0\alpha_1\cdots\alpha_n}$.

Let $N = \{N_\alpha\}_{\alpha \in \pi}$ be a π -subcomodule of a right π -comodule $M = \{M_\alpha\}_{\alpha \in \pi}$ over a π -coalgebra C . One easily checks that $M/N = \{M_\alpha/N_\alpha\}_{\alpha \in \pi}$ is a right π -comodule over C , with structure maps naturally induced from the structure maps of M . Moreover this is the unique structure of a right π -comodule over C on M/N which makes the canonical projection $p = \{p_\alpha : M_\alpha \rightarrow M_\alpha/N_\alpha\}_{\alpha \in \pi}$ a π -comodule morphism.

If $f = \{f_\alpha : M_\alpha \rightarrow M'_\alpha\}_{\alpha \in \pi}$ is a π -comodule morphism between two right π -comodules M and M' , then $\ker(f) = \{\ker(f_\alpha)\}_{\alpha \in \pi}$ is a π -subcomodule of M , $f(M) = \{f_\alpha(M_\alpha)\}_{\alpha \in \pi}$ is a π -subcomodule of M' , and the canonical isomorphism $\tilde{f} = \{\tilde{f}_\alpha : M_\alpha/\ker(f_\alpha) \rightarrow f_\alpha(M_\alpha)\}_{\alpha \in \pi}$ is a π -comodule isomorphism.

EXAMPLE 1.3. Let $H = \{H_\alpha\}_{\alpha \in \pi}$ be a Hopf π -coalgebra and $M = \{M_\alpha\}_{\alpha \in \pi}$ be a right π -comodule over H with structure maps $\rho = \{\rho_{\alpha,\beta}\}_{\alpha,\beta \in \pi}$. The *coinvariants of H on M* are the elements of the \mathbb{k} -space

$$\{m = (m_\alpha)_{\alpha \in \pi} \in \prod_{\alpha \in \pi} M_\alpha \mid \rho_{\alpha,\beta}(m_{\alpha\beta}) = m_\alpha \otimes 1_\beta \text{ for all } \alpha, \beta \in \pi\}.$$

For any $\alpha \in \pi$, let $M_\alpha^{\text{co}H}$ be the image of the (canonical) projection of this set onto M_α . It is easy to verify that $M^{\text{co}H} = \{M_\alpha^{\text{co}H}\}_{\alpha \in \pi}$ is a right π -subcomodule of M , called the π -subcomodule of *coinvariants*.

1.2.2. Rational π -graded modules. Throughout this subsection, $C = (\{C_\alpha\}, \Delta, \varepsilon)$ will denote a π -coalgebra and $C^* = \bigoplus_{\alpha \in \pi} C_\alpha^*$ its dual π -graded algebra (see §1.1.2). In this subsection we explore the relationships between right π -comodules over C and π -graded left C^* -modules.

Recall that a left module M over a π -graded algebra $A = \bigoplus_{\alpha \in \pi} A_\alpha$ is *graded* if M admits a decomposition as a direct sum of \mathbb{k} -spaces $M = \bigoplus_{\alpha \in \pi} M_\alpha$ such that $A_\alpha M_\beta \subset M_{\alpha\beta}$ for all $\alpha, \beta \in \pi$. A submodule N of M is *graded* if $N = \bigoplus_{\alpha \in \pi} (N \cap M_\alpha)$. The quotient M/N is then a left π -graded A -module by setting $(M/N)_\alpha = (M_\alpha + N)/N$ for all $\alpha \in \pi$. This is the unique structure of a π -graded A -module on M/N which makes the canonical projection $M \rightarrow M/N$ a graded A -morphism.

Let $M = \bigoplus_{\alpha \in \pi} M_\alpha$ be a π -graded left C^* -module with action $\psi : C^* \otimes M \rightarrow M$. Set $\overline{M}_\alpha = M_{\alpha^{-1}}$. For any $\alpha, \beta \in \pi$, define

$$(1.8) \quad \rho_{\alpha, \beta} : \overline{M}_{\alpha\beta} \rightarrow \text{Hom}_{\mathbb{k}}(C_\beta^*, \overline{M}_\alpha) \quad \text{by} \quad \rho_{\alpha, \beta}(m)(f) = \psi(f \otimes m).$$

There is a natural embedding

$$\overline{M}_\alpha \otimes C_\beta \hookrightarrow \text{Hom}_{\mathbb{k}}(C_\beta^*, \overline{M}_\alpha) \quad m \otimes c \mapsto (f \mapsto f(c)m).$$

Regard this embedding as inclusion, so that $\overline{M}_\alpha \otimes C_\beta \subset \text{Hom}_{\mathbb{k}}(C_\beta^*, \overline{M}_\alpha)$. The π -graded left C^* -module M is said to be *rational* if $\rho_{\alpha, \beta}(\overline{M}_{\alpha\beta}) \subset \overline{M}_\alpha \otimes C_\beta$ for all $\alpha, \beta \in \pi$. In this case, the restriction of $\rho_{\alpha, \beta}$ onto $\overline{M}_\alpha \otimes C_\beta$ will also be denoted by

$$(1.9) \quad \rho_{\alpha, \beta} : \overline{M}_{\alpha\beta} \rightarrow \overline{M}_\alpha \otimes C_\beta.$$

The definition given here generalizes that of a rational π -graded left module given in [32] and agrees with it when π is finite.

The next theorem generalizes [32, THEOREM 6.3] and [45, THEOREM 2.1.3].

THEOREM 1.4. *Let $C = \{C_\alpha\}_{\alpha \in \pi}$ be a π -coalgebra and C^* be its dual π -graded algebra. Then*

- (a) *There is a one-to-one correspondence between (isomorphic classes of) right π -comodules over C and (isomorphic classes of) rational π -graded left C^* -modules.*
- (b) *Every graded submodule of a rational π -graded left C^* -module is rational.*
- (c) *Any π -graded left C^* -module $L = \bigoplus_{\alpha \in \pi} L_\alpha$ has a unique maximal rational graded submodule, noted L^{rat} , which is equal to the sum of all rational graded submodules of L . Moreover, if $\rho = \{\rho_{\alpha, \beta}\}_{\alpha, \beta \in \pi}$ is defined as in (1.8), then $(L^{\text{rat}})_\gamma = \bigcap_{\substack{\alpha, \beta \in \pi \\ \alpha\beta = \gamma^{-1}}} \rho_{\alpha, \beta}^{-1}(\overline{L}_\alpha \otimes C_\beta)$ for*

any $\gamma \in \pi$.

Before proving the theorem, we need two lemmas. Let $M = \{M_\alpha\}_{\alpha \in \pi}$ be a family of \mathbb{k} -spaces and $\rho = \{\rho_{\alpha, \beta} : M_{\alpha\beta} \rightarrow M_\alpha \otimes C_\beta\}_{\alpha, \beta \in \pi}$ be a family of \mathbb{k} -linear maps. Set $\overline{M} = \bigoplus_{\alpha \in \pi} \overline{M}_\alpha$, where $\overline{M}_\alpha = M_{\alpha^{-1}}$. Let $\psi_\rho : C^* \otimes \overline{M} \rightarrow \overline{M}$ be the \mathbb{k} -linear map defined on the summands by

$$C_\alpha^* \otimes \overline{M}_\beta \xrightarrow{\text{id}_{C_\alpha^*} \otimes \rho_{(\alpha\beta)^{-1}, \alpha}} C_\alpha^* \otimes \overline{M}_{\alpha\beta} \otimes C_\alpha \xrightarrow{\sigma_{C_\alpha^*, \overline{M}_{\alpha\beta}} \otimes \text{id}_{C_\alpha}} \overline{M}_{\alpha\beta} \otimes C_\alpha^* \otimes C_\alpha \xrightarrow{\text{id}_{\overline{M}_{\alpha\beta}} \otimes \langle \cdot, \cdot \rangle} \overline{M}_{\alpha\beta} \otimes \mathbb{k} \cong \overline{M}_{\alpha\beta},$$

where $\langle \cdot, \cdot \rangle$ denotes the natural pairing between C_α^* and C_α .

LEMMA 1.5. *(M, ρ) is a right π -comodule over C if and only if $(\overline{M}, \psi_\rho)$ is a π -graded left C^* -module.*

Proof. Suppose that (M, ρ) is a right π -comodule over C . Firstly, using (1.7), we have that $\psi_\rho(\varepsilon \otimes m) = m_{(0, \alpha^{-1})} \varepsilon(m_{(1, 1)}) = m$ for any $m \in \overline{M}_\alpha$. Secondly, for any $f \in C_\alpha^*$, $g \in C_\beta^*$, and $m \in \overline{M}_\gamma$, we have

$$\begin{aligned} \psi_\rho(fg \otimes m) &= m_{(0, (\alpha\beta\gamma)^{-1})} fg(m_{(1, \alpha\beta)}) \\ &= m_{(0, (\alpha\beta\gamma)^{-1})} f(m_{(1, \alpha)}) g(m_{(2, \beta)}) \end{aligned}$$

$$\begin{aligned}
&= \psi_\rho(f \otimes m_{(0,(\beta\gamma)^{-1})}g(m_{(1,\beta)})) \\
&= \psi_\rho(f \otimes \psi_\rho(g \otimes m)).
\end{aligned}$$

Moreover, by construction, $\psi_\rho(C_\alpha^* \otimes \overline{M}_\beta) \subset \overline{M}_{\alpha\beta}$ for any $\alpha, \beta \in \pi$. Hence $(\overline{M}, \psi_\rho)$ is a π -graded left C^* -module.

Conversely, suppose that $(\overline{M}, \psi_\rho)$ is a left π -graded C^* -module. Axiom (1.7) is satisfied since $(\text{id}_{M_\alpha} \otimes \varepsilon)\rho_{\alpha,1}(m) = \psi_\rho(\varepsilon \otimes m) = m$ for all $\alpha \in \pi$ and $m \in M_\alpha = \overline{M}_{\alpha^{-1}}$. To show that Axiom (1.6) is satisfied, let $\alpha, \beta, \gamma \in \pi$ and $m \in M_{\alpha\beta\gamma}$. Set

$$\delta = (\rho_{\alpha,\beta} \otimes \text{id}_{C_\gamma})\rho_{\alpha\beta,\gamma}(m) - (\text{id}_{M_\alpha} \otimes \Delta_{\beta,\gamma})\rho_{\alpha,\beta\gamma}(m) \in M_\alpha \otimes C_\beta \otimes C_\gamma.$$

Suppose that $\delta \neq 0$. Then there exists $F \in (M_\alpha \otimes C_\beta \otimes C_\gamma)^*$ such that $F(\delta) \neq 0$. Now $M_\alpha^* \otimes C_\beta^* \otimes C_\gamma^*$ is dense in the linear topological space $(M_\alpha \otimes C_\beta \otimes C_\gamma)^*$ endowed with the $(M_\alpha \otimes C_\beta \otimes C_\gamma)$ -topology (see [1, PAGE 70]). Thus $(M_\alpha^* \otimes C_\beta^* \otimes C_\gamma^*) \cap (F + \delta^\perp) \neq \emptyset$, where $\delta^\perp = \{f \in (M_\alpha \otimes C_\beta \otimes C_\gamma)^* \mid f(\delta) = 0\}$. Then there exists $G \in M_\alpha^* \otimes C_\beta^* \otimes C_\gamma^*$ such that $G(\delta) \neq 0$. Now, for all $f \in M_\alpha^*$, $g \in C_\beta^*$, and $h \in C_\gamma^*$, we have

$$\begin{aligned}
(f \otimes g \otimes h)(\rho_{\alpha,\beta} \otimes \text{id}_{C_\gamma})\rho_{\alpha\beta,\gamma}(m) &= f \circ \psi_\rho(g \otimes \psi_\rho(h \otimes m)) \\
&= f \circ \psi_\rho(gh \otimes m) \\
&= (f \otimes g \otimes h)(\text{id}_{M_\alpha} \otimes \Delta_{\beta,\gamma})\rho_{\alpha,\beta\gamma}(m),
\end{aligned}$$

i.e., $(f \otimes g \otimes h)(\delta) = 0$. Therefore $G(\delta) = 0$, which is a contradiction. We conclude that $\delta = 0$ and then $(\rho_{\alpha,\beta} \otimes \text{id}_{C_\gamma})\rho_{\alpha\beta,\gamma} = (\text{id}_{M_\alpha} \otimes \Delta_{\beta,\gamma})\rho_{\alpha,\beta\gamma}$. Hence (M, ρ) is a right π -comodule over C . \square

LEMMA 1.6. *Let $(M = \bigoplus_{\alpha \in \pi} M_\alpha, \psi)$ be a rational π -graded left C^* -module. Then $\overline{M} = \{\overline{M}_\alpha\}_{\alpha \in \pi}$, endowed with the structure maps $\rho = \{\rho_{\alpha,\beta}\}_{\alpha,\beta \in \pi}$ defined by (1.9), is a right π -comodule over C .*

Proof. Let $\psi_\rho : C^* \otimes \overline{\overline{M}} \rightarrow \overline{\overline{M}}$ be the map defined as in Lemma 1.5. It is easy to verify that $(\overline{\overline{M}}, \psi_\rho) = (M, \psi)$. Thus $(\overline{\overline{M}}, \psi_\rho)$ is a π -graded left C^* -module and hence, by Lemma 1.5, $(\overline{\overline{M}}, \rho)$ is a right π -comodule over C . \square

Proof of Theorem 1.4. Part (a) follows directly from Lemmas 1.5 and 1.6. To show Part (b), let N be a graded submodule of a rational π -graded left C^* -module (M, ψ) . Let $\rho_{\alpha,\beta} : \overline{N}_{\alpha\beta} \rightarrow \text{Hom}_{\mathbb{k}}(C_\beta^*, \overline{N}_\alpha)$ defined by $\rho_{\alpha,\beta}(m)(f) = \psi(f \otimes m)$. Suppose that there exist $\alpha, \beta \in \pi$ and $n \in \overline{N}_{\alpha\beta}$ such that $\rho_{\alpha,\beta}(n) \notin \overline{N}_\alpha \otimes C_\beta$. Since M is rational, we can write $\rho_{\alpha,\beta}(n) = \sum_{i=1}^k n_i \otimes c_i \in \overline{M}_\alpha \otimes C_\beta$. Without loss of generality, we can assume that the c_i are \mathbb{k} -linearly independent and $n_1 \notin \overline{N}_\alpha$. Let $f \in C_\beta^*$ such that $f(c_1) = 1$ and $f(c_i) = 0$ for $i \geq 2$. Now $\psi(f \otimes n) = \sum_{i=1}^k n_i f(c_i) = n_1 \notin \overline{N}_\alpha = N_{\alpha^{-1}}$, contradicting the fact that N is a graded submodule of M . Thus $\rho_{\alpha,\beta}(\overline{N}_{\alpha\beta}) \subset \overline{N}_\alpha \otimes C_\beta$ for all $\alpha, \beta \in \pi$. Hence N is rational.

Let us show Part (c). Denote by \cdot the left action of C^* on L . Set $\overline{L}_\alpha = L_{\alpha^{-1}}$ and $\rho_{\alpha,\beta} : \overline{L}_{\alpha\beta} \rightarrow \text{Hom}_{\mathbb{k}}(C_\beta^*, \overline{L}_\alpha)$ given by $\rho_{\alpha,\beta}(m)(f) = f \cdot m$. Recall $\overline{L}_\alpha \otimes C_\beta$ can be viewed as a subspace of $\text{Hom}_{\mathbb{k}}(C_\beta^*, \overline{L}_\alpha)$ via the embedding $\overline{L}_\alpha \otimes C_\beta \hookrightarrow \text{Hom}_{\mathbb{k}}(C_\beta^*, \overline{L}_\alpha)$ given by $m \otimes c \mapsto (f \mapsto f(c)m)$. Define $M_\gamma = \bigcap_{\alpha\beta=\gamma^{-1}} \rho_{\alpha,\beta}^{-1}(\overline{L}_\alpha \otimes C_\beta) \subset L_\gamma$ for any $\gamma \in \pi$, and set $M = \bigoplus_{\gamma \in \pi} M_\gamma$. Fix $\alpha, \beta \in \pi$, $f \in C_\alpha^*$, and $m \in M_\beta \subset \overline{L}_{\beta^{-1}}$. Let $u, v \in \pi$ such that $uv = (\alpha\beta)^{-1}$. We can write $\rho_{u,v\alpha}(m) = \sum_{i=1}^k l_i \otimes c_i \in \overline{L}_u \otimes C_{v\alpha}$. Now, for any $g \in C_v^*$,

$$g \cdot (f \cdot m) = (gf) \cdot m = \sum_{i=1}^k gf(c_i) l_i = \sum_{i=1}^k g(f(c_{i(2,\alpha)}))c_{i(1,v)} l_i.$$

Then $\rho_{u,v}(f \cdot m) = \sum_{i=1}^k l_i \otimes f(c_{i(2,\alpha)})c_{i(1,v)} \in \bar{L}_u \otimes C_v$ and so $f \cdot m \in \rho_{u,v}^{-1}(\bar{L}_u \otimes C_v)$. Hence $f \cdot m \in \cap_{uv=(\alpha\beta)^{-1}} \rho_{u,v}^{-1}(\bar{L}_u \otimes C_v) = M_{\alpha\beta}$. Therefore M is a graded submodule of L . Moreover one easily checks at this point that $\rho_{\alpha,\beta}(\bar{M}_{\alpha\beta}) \subset \bar{M}_\alpha \otimes C_\beta$ for any $\alpha, \beta \in \pi$. Thus M is rational.

Suppose now that N is another rational graded submodule of L and denote by $\varrho = \{\varrho_{\alpha,\beta}\}_{\alpha,\beta \in \pi}$ its corresponding π -comodule structure maps (see Lemma 1.6). Fix $\gamma \in \pi$ and let $\alpha, \beta \in \pi$ with $\alpha\beta = \gamma^{-1}$. By the definition of $\rho_{\alpha,\beta}$ and $\varrho_{\alpha,\beta}$ and of the embedding $\bar{N}_\alpha \otimes C_\beta \subset \bar{L}_\alpha \otimes C_\beta \subset \text{Hom}_{\mathbb{K}}(C_\beta^*, \bar{L}_\alpha)$, it follows that $\rho_{\alpha,\beta}|_N = \varrho_{\alpha,\beta} : \bar{N}_{\alpha\beta} \rightarrow \bar{N}_\alpha \otimes C_\beta$. Thus $\rho_{\alpha,\beta}(N_\gamma) = \varrho_{\alpha,\beta}(\bar{N}_{\alpha\beta}) \subset \bar{N}_\alpha \otimes C_\beta \subset \bar{L}_\alpha \otimes C_\beta$, and so $N_\gamma \subset \rho_{\alpha,\beta}^{-1}(\bar{L}_\alpha \otimes C_\beta)$. This holds for all $\alpha, \beta \in \pi$ such that $\alpha\beta = \gamma^{-1}$. Thus $N_\gamma \subset \cap_{\alpha\beta=\gamma^{-1}} \rho_{\alpha,\beta}^{-1}(\bar{L}_\alpha \otimes C_\beta) = M_\gamma$ for any $\gamma \in \pi$. Hence $N \subset M$. Therefore M is the unique maximal rational graded submodule of L and is the sum of all rational graded submodules of L . \square

REMARK. It follows from Lemma 1.6 and Theorem 1.4(c) that a unique ‘‘maximal’’ right π -comodule (M^{rat}) over a π -coalgebra $C = \{C_\alpha\}_{\alpha \in \pi}$ can be associated to any π -graded left C^* -module M .

1.2.3. Hopf π -comodules. In this subsection, we introduce and discuss the notion of a Hopf π -comodule.

Let $H = (\{H_\alpha\}, \Delta, \varepsilon, S)$ be a Hopf π -coalgebra. A *right Hopf π -comodule over H* is a right π -comodule $M = \{M_\alpha\}_{\alpha \in \pi}$ over H such that

(1.10) M_α is a right H_α -module for any $\alpha \in \pi$;

(1.11) Let us denote by $\psi_\alpha : M_\alpha \otimes H_\alpha \rightarrow M_\alpha$ the right action of H_α on M_α and by $\rho = \{\rho_{\alpha,\beta}\}_{\alpha,\beta \in \pi}$ the π -comodule maps of M . These structures are required to be compatible in the sense that, for any $\alpha, \beta \in \pi$, the diagram of Figure 1.1 is commutative.

$$\begin{array}{ccccc}
 M_{\alpha\beta} \otimes H_{\alpha\beta} & \xrightarrow{\psi_{\alpha\beta}} & M_{\alpha\beta} & \xrightarrow{\rho_{\alpha,\beta}} & M_\alpha \otimes H_\beta \\
 \downarrow \rho_{\alpha,\beta} \otimes \Delta_{\alpha,\beta} & & & & \uparrow \psi_{\alpha \otimes m_\beta} \\
 M_\alpha \otimes H_\beta \otimes H_\alpha \otimes H_\beta & \xrightarrow{\text{id}_{M_\alpha} \otimes \sigma_{H_\beta, H_\alpha} \otimes \text{id}_{H_\beta}} & & & M_\alpha \otimes H_\alpha \otimes H_\beta \otimes H_\beta
 \end{array}$$

FIGURE 1.1. Compatibility of the structure maps of a right Hopf π -comodule

When $\pi = 1$, one recovers the definition of a Hopf module (see [24]).

Note that Axiom (1.11) means that $\rho_{\alpha,\beta} : M_{\alpha\beta} \rightarrow M_\alpha \otimes H_\beta$ is $H_{\alpha\beta}$ -linear, where $M_\alpha \otimes H_\beta$ is endowed with the right $H_{\alpha\beta}$ -module structure given by

$$(m \otimes h) \cdot a = \psi_\alpha(m \otimes a_{(1,\alpha)}) \otimes h a_{(2,\beta)}.$$

A *Hopf π -subcomodule of M* is a π -subcomodule $N = \{N_\alpha\}_{\alpha \in \pi}$ of M such that N_α is a H_α -submodule of M_α for any $\alpha \in \pi$. Then N is a right Hopf π -comodule over H .

A *Hopf π -comodule morphism* between two right Hopf π -comodules M and M' is a π -comodule morphism $f = \{f_\alpha : M_\alpha \rightarrow M'_\alpha\}_{\alpha \in \pi}$ between M and M' such that f_α is H_α -linear for any $\alpha \in \pi$.

EXAMPLE 1.7. Let $H = \{H_\alpha\}_{\alpha \in \pi}$ be a Hopf π -coalgebra and $M = \{M_\alpha\}_{\alpha \in \pi}$ be a right π -comodule over H , with structure maps $\rho = \{\rho_{\alpha,\beta}\}_{\alpha,\beta \in \pi}$. For any $\alpha \in \pi$, set $(M \otimes H)_\alpha = M_\alpha \otimes H_\alpha$. The multiplication in H_α induces a structure of a right H_α -module on $(M \otimes H)_\alpha$ by setting $(m \otimes h) \triangleleft a = m \otimes ha$. Define the π -comodule structure maps $\xi_{\alpha,\beta} : (M \otimes H)_{\alpha\beta} \rightarrow (M \otimes H)_\alpha \otimes H_\beta$ by

$$\xi_{\alpha,\beta}(m \otimes h) = m_{(0,\alpha)} \otimes h_{(1,\alpha)} \otimes m_{(1,\beta)} h_{(2,\beta)},$$

where we write as usual $\rho_{\alpha,\beta}(m) = m_{(0,\alpha)} \otimes m_{(1,\beta)}$ and $\Delta_{\alpha,\beta}(h) = h_{(1,\alpha)} \otimes h_{(2,\beta)}$. One easily verifies that $M \otimes H = \{(M \otimes H)_\alpha\}_{\alpha \in \pi}$ is a right Hopf π -comodule over H , called *trivial*.

In the next theorem, we show that a Hopf π -comodule can be canonically decomposed. This generalizes the fundamental theorem of Hopf modules (see [24, PROPOSITION 1]).

THEOREM 1.8. *Let $H = \{H_\alpha\}_{\alpha \in \pi}$ be a Hopf π -coalgebra and M be a right Hopf π -comodule over H . Consider the π -subcomodule of coinvariants $M^{\text{co}H}$ of M (see Example 1.3) and the trivial right Hopf π -comodule $M^{\text{co}H} \otimes H$ (see Example 1.7). Then there exists a Hopf π -comodule isomorphism $M \cong M^{\text{co}H} \otimes H$.*

Proof. We will denote by \cdot (resp. \triangleleft) the right action of H_α on M_α (resp. on $(M^{\text{co}H} \otimes H)_\alpha$) and by $\rho = \{\rho_{\alpha,\beta}\}_{\alpha,\beta \in \pi}$ (resp. $\xi = \{\xi_{\alpha,\beta}\}_{\alpha,\beta \in \pi}$) the π -comodule structure maps of M (resp. of $M^{\text{co}H} \otimes H$). For any $\alpha \in \pi$, define $P_\alpha : M_1 \rightarrow M_\alpha$ by $P_\alpha(m) = m_{(0,\alpha)} \cdot S_{\alpha^{-1}}(m_{(1,\alpha^{-1})})$. Remark first that, for any $m \in M_1$, $(P_\alpha(m))_{\alpha \in \pi}$ is a coinvariant of H on M . Indeed, for all $\alpha, \beta \in \pi$,

$$\begin{aligned} \rho_{\alpha,\beta}(P_\alpha(m)) &= \rho_{\alpha,\beta}(m_{(0,\alpha\beta)} \cdot S_{(\alpha\beta)^{-1}}(m_{(1,(\alpha\beta)^{-1})})) \\ &= \rho_{\alpha,\beta}(m_{(0,\alpha\beta)}) \cdot \Delta_{\alpha,\beta} S_{(\alpha\beta)^{-1}}(m_{(1,(\alpha\beta)^{-1})}) \quad \text{by (1.11)} \\ &= m_{(0,\alpha)} \cdot S_{\alpha^{-1}}(m_{(3,\alpha^{-1})}) \otimes m_{(1,\beta)} S_{\beta^{-1}}(m_{(2,\beta^{-1})}) \quad \text{by Lemma 1.1(c)} \\ &= m_{(0,\alpha)} \cdot S_{\alpha^{-1}}(\varepsilon(m_{(1,1)}) m_{(2,\alpha^{-1})}) \otimes 1_\beta \quad \text{by (1.5)} \\ &= m_{(0,\alpha)} \cdot S_{\alpha^{-1}}(m_{(1,\alpha^{-1})}) \otimes 1_\beta \quad \text{by (1.2)} \\ &= P_\alpha(m) \otimes 1_\beta. \end{aligned}$$

For any $\alpha \in \pi$, define $f_\alpha : (M^{\text{co}H} \otimes H)_\alpha \rightarrow M_\alpha$ by $f_\alpha(m \otimes h) = m \cdot h$. Then f_α is H_α -linear since $f_\alpha(m \otimes h) \cdot a = (m \cdot h) \cdot a = m \cdot ha = f_\alpha((m \otimes h) \triangleleft a)$ for all $m \in M_\alpha^{\text{co}H}$ and $h, a \in H_\alpha$. Moreover $(f_\alpha \otimes \text{id}_{H_\beta}) \xi_{\alpha,\beta} = \rho_{\alpha,\beta} f_{\alpha\beta}$ for all $\alpha, \beta \in \pi$. Indeed let $m \in M_{\alpha\beta}^{\text{co}H}$ and $h \in H_{\alpha\beta}$. By the definition of $M_{\alpha\beta}^{\text{co}H}$, there exists a coinvariant $(m_\gamma)_{\gamma \in \pi}$ of H on M such that $m_{\alpha\beta} = m$. In particular $\rho_{\alpha,\beta}(m) = m_\alpha \otimes 1_\beta$. Thus

$$\begin{aligned} (f_\alpha \otimes \text{id}_{H_\beta}) \xi_{\alpha,\beta}(m \otimes h) &= m_\alpha \cdot h_{(1,\alpha)} \otimes h_{(2,\beta)} \\ &= \rho_{\alpha,\beta}(m) \cdot \Delta_{\alpha,\beta}(h) \\ &= \rho_{\alpha,\beta}(m \cdot h) \quad \text{by (1.11)} \\ &= \rho_{\alpha,\beta}(f_{\alpha\beta}(m \otimes h)). \end{aligned}$$

Then $f = \{f_\alpha\}_{\alpha \in \pi} : M^{\text{co}H} \otimes H \rightarrow M$ is a Hopf π -comodule morphism. To show that f is an isomorphism, we construct its inverse. For any $\alpha \in \pi$, define $g_\alpha : M_\alpha \rightarrow (M^{\text{co}H} \otimes H)_\alpha$ by $g_\alpha = (P_\alpha \otimes \text{id}_{H_\alpha}) \rho_{1,\alpha}$. The map g_α is well-defined since $(P_\gamma(m))_{\gamma \in \pi}$ is a coinvariant of H on M for all $m \in M_1$, and is H_α -linear since, for any $x \in M_\alpha$ and $a \in H_\alpha$,

$$\begin{aligned} g_\alpha(x \cdot a) &= (P_\alpha \otimes \text{id}_{H_\alpha}) \rho_{1,\alpha}(x \cdot a) \\ &= P_\alpha(x_{(0,1)} \cdot a_{(1,1)}) \otimes x_{(1,\alpha)} a_{(2,\alpha)} \quad \text{by (1.11)} \\ &= (x_{(0,\alpha)} \cdot a_{(1,\alpha)}) \cdot S_{\alpha^{-1}}(x_{(1,\alpha^{-1})} a_{(2,\alpha^{-1})}) \otimes x_{(2,\alpha)} a_{(3,\alpha)} \quad \text{by (1.11)} \\ &= x_{(0,\alpha)} \cdot (a_{(1,\alpha)} S_{\alpha^{-1}}(a_{(2,\alpha^{-1})}) S_{\alpha^{-1}}(x_{(1,\alpha^{-1})})) \otimes x_{(2,\alpha)} a_{(3,\alpha)} \\ &= x_{(0,\alpha)} \cdot S_{\alpha^{-1}}(x_{(1,\alpha^{-1})}) \otimes x_{(2,\alpha)} \varepsilon(a_{(1,1)}) a_{(2,\alpha)} \quad \text{by (1.5)} \end{aligned}$$

$$\begin{aligned}
&= x_{(0,\alpha)} \cdot S_{\alpha^{-1}}(x_{(1,\alpha^{-1})}) \otimes x_{(2,\alpha)} a \quad \text{by (1.2)} \\
&= g_{\alpha}(x) \triangleleft a.
\end{aligned}$$

Moreover $(g_{\alpha} \otimes \text{id}_{H_{\beta}})\rho_{\alpha,\beta} = \xi_{\alpha,\beta}g_{\alpha\beta}$ for all $\alpha, \beta \in \pi$. Indeed, for any $x \in M_{\alpha\beta}$,

$$\begin{aligned}
\xi_{\alpha,\beta}(g_{\alpha\beta}(x)) &= \xi_{\alpha,\beta}(P_{\alpha\beta}(x_{(0,1)}) \otimes x_{(1,\alpha\beta)}) \\
&= P_{\alpha\beta}(x_{(0,1)})_{(0,\alpha)} \otimes x_{(1,\alpha\beta)(1,\alpha)} \otimes P_{\alpha\beta}(x_{(1,1)})_{(1,\beta)} x_{(1,\alpha\beta)(2,\beta)},
\end{aligned}$$

and so, since $(P_{\gamma}(x_{(0,1)}))_{\gamma \in \pi}$ is a π -coinvariant of H on M ,

$$\begin{aligned}
\xi_{\alpha,\beta}(g_{\alpha\beta}(x)) &= P_{\alpha}(x_{(0,1)}) \otimes x_{(1,\alpha)} \otimes x_{(2,\beta)} \\
&= g_{\alpha}(x_{(0,\alpha)}) \otimes x_{(1,\beta)} \\
&= (g_{\alpha} \otimes \text{id}_{H_{\beta}})\rho_{\alpha,\beta}(x).
\end{aligned}$$

Thus $g = \{g_{\alpha}\}_{\alpha \in \pi} : M \rightarrow M^{\text{co}H} \otimes H$ is a Hopf π -comodule morphism. It remains now to verify that $g_{\alpha}f_{\alpha} = \text{id}_{(M^{\text{co}H} \otimes H)_{\alpha}}$ and $f_{\alpha}g_{\alpha} = \text{id}_{M_{\alpha}}$ for any $\alpha \in \pi$. Let $m \in M_{\alpha}^{\text{co}H}$ and $h \in H_{\alpha}$. By the definition of $M_{\alpha}^{\text{co}H}$, there exists a coinvariant $(m_{\gamma})_{\gamma \in \pi}$ of H on M such that $m_{\alpha} = m$. In particular, $\rho_{1,\alpha}(m) = m_1 \otimes 1_{\alpha}$ and $P_{\alpha}(m_1) = m_{\alpha} \cdot S_{\alpha^{-1}}(1_{\alpha^{-1}}) = m \cdot 1_{\alpha} = m$. Then

$$\begin{aligned}
g_{\alpha}f_{\alpha}(m \otimes h) &= g_{\alpha}(m \cdot h) \\
&= g_{\alpha}(m) \triangleleft h \quad \text{since } g_{\alpha} \text{ is } H_{\alpha}\text{-linear} \\
&= (P_{\alpha}(m_1) \otimes 1_{\alpha}) \triangleleft h \\
&= m \otimes h.
\end{aligned}$$

Finally, for all $x \in M_{\alpha}$,

$$\begin{aligned}
f_{\alpha}g_{\alpha}(x) &= (x_{(0,\alpha)} \cdot S_{\alpha^{-1}}(x_{(1,\alpha^{-1})})) \cdot x_{(2,\alpha)} \\
&= x_{(0,\alpha)} \cdot (S_{\alpha^{-1}}(x_{(1,\alpha^{-1})}) x_{(2,\alpha)}) \\
&= x_{(0,\alpha)} \varepsilon(x_{(1,1)}) \cdot 1_{\alpha} \quad \text{by (1.5)} \\
&= x \quad \text{by (1.7)}.
\end{aligned}$$

Hence $g = f^{-1}$ and f and g are Hopf π -comodule isomorphisms. \square

1.3. Existence and uniqueness of π -integrals

In this section, we introduce and discuss the notion of a π -integral for a Hopf π -coalgebra. In particular, by generalizing the arguments of [45, §5], we show that, in the finite type case, the space of left (resp. right) π -integrals is one-dimensional.

1.3.1. π -integrals. We first recall that a left (resp. right) integral for a Hopf algebra $(A, \Delta, \varepsilon, S)$ is an element $\Lambda \in A$ such that $x\Lambda = \varepsilon(x)\Lambda$ (resp. $\Lambda x = \varepsilon(x)\Lambda$) for all $x \in A$. A left (resp. right) integral for the dual Hopf algebra A^* is a \mathbb{k} -linear form $\lambda \in A^*$ verifying $(f \otimes \lambda)\Delta = f(1_A)\lambda$ (resp. $(\lambda \otimes f)\Delta = f(1_A)\lambda$) for all $f \in A^*$. Let us extend this notion to the setting of a Hopf π -coalgebra.

Let $H = (\{H_{\alpha}, m_{\alpha}, 1_{\alpha}\}, \Delta, \varepsilon, S)$ be a Hopf π -coalgebra. A left (resp. right) π -integral for H is a family of \mathbb{k} -linear forms $\lambda = (\lambda_{\alpha})_{\alpha \in \pi} \in \prod_{\alpha \in \pi} H_{\alpha}^*$ such that, for all $\alpha, \beta \in \pi$,

$$(1.12) \quad (\text{id}_{H_{\alpha}} \otimes \lambda_{\beta})\Delta_{\alpha,\beta} = \lambda_{\alpha\beta} 1_{\alpha} \quad (\text{resp. } (\lambda_{\alpha} \otimes \text{id}_{H_{\beta}})\Delta_{\alpha,\beta} = \lambda_{\alpha\beta} 1_{\beta}).$$

Note that λ_1 is a usual left (resp. right) integral for the Hopf algebra H_1^* .

If we use the multiplication of the dual π -graded algebra H^* of H (see §1.1.2), we have that $\lambda = (\lambda_{\alpha})_{\alpha \in \pi} \in \prod_{\alpha \in \pi} H_{\alpha}^*$ is a left (resp. right) π -integral for H if and only if $f\lambda_{\beta} = f(1_{\alpha})\lambda_{\alpha\beta}$ (resp. $\lambda_{\alpha}g = g(1_{\alpha})\lambda_{\alpha\beta}$) for all $\alpha, \beta \in \pi$ and $f \in H_{\alpha}^*$ (resp. $g \in H_{\beta}^*$).

A π -integral $\lambda = (\lambda_{\alpha})_{\alpha \in \pi}$ for H is said to be *non-zero* if $\lambda_{\beta} \neq 0$ for some $\beta \in \pi$.

LEMMA 1.9. *Let $\lambda = (\lambda_\alpha)_{\alpha \in \pi}$ be a non-zero left (resp. right) π -integral for H . Then $\lambda_\alpha \neq 0$ for all $\alpha \in \pi$ such that $H_\alpha \neq 0$. In particular $\lambda_1 \neq 0$.*

Proof. Let $\lambda = (\lambda_\alpha)_{\alpha \in \pi}$ be a left π -integral for H such that $\lambda_\beta \neq 0$ for some $\beta \in \pi$ and let $\alpha \in \pi$ with $H_\alpha \neq 0$. Then $H_{\beta\alpha^{-1}} \neq 0$ (by Corollary 1.2) and so $1_{\beta\alpha^{-1}} \neq 0$. Using (1.12), we have that $(\text{id}_{H_{\beta\alpha^{-1}}} \otimes \lambda_\alpha)\Delta_{\beta\alpha^{-1}, \alpha} = \lambda_\beta 1_{\beta\alpha^{-1}} \neq 0$. Hence $\lambda_\alpha \neq 0$. The right case can be done similarly. \square

REMARK. Let $H = \{H_\alpha\}_{\alpha \in \pi}$ be a finite type Hopf π -coalgebra. Consider the Hopf algebra H^* dual to H (see §1.1.3.4). If $H_\alpha = 0$ for all but a finite number of $\alpha \in \pi$, then $\lambda = (\lambda_\alpha)_{\alpha \in \pi} \in \Pi_{\alpha \in \pi} H_\alpha^*$ is a left (resp. right) π -integral for H if and only if $\sum_{\alpha \in \pi} \lambda_\alpha$ is a left (resp. right) integral for H^* . If $H_\alpha \neq 0$ for infinitely many $\alpha \in \pi$, then H^* is infinite-dimensional and thus does not have any non-zero left or right integral (see [46]). Nevertheless we show in the next subsection that H always has a non-zero π -integral.

1.3.2. The space of π -integrals is one-dimensional. It is known (see [45, COROLLARY 5.1.6]) that the space of left (resp. right) integrals for a finite-dimensional Hopf algebra is one-dimensional. In this subsection, we generalize this result to finite type Hopf π -coalgebras.

Let $H = \{H_\alpha\}_{\alpha \in \pi}$ be a Hopf π -coalgebra (not necessarily of finite type). The dual π -graded algebra H^* of H (see §1.1.2) is a π -graded left H^* -module via left multiplication. Let $(H^*)^{\text{rat}}$ be its maximal rational π -graded submodule (see Theorem 1.4(c)). Denote by $H^\square = \overline{(H^*)^{\text{rat}}} = \{H_\alpha^\square\}_{\alpha \in \pi}$ the right π -comodule over H which corresponds to it by Lemma 1.6. Recall that $H_\alpha^\square \subset H_{\alpha^{-1}}^*$ for any $\alpha \in \pi$. The π -comodule structure maps of H^\square will be denoted by $\rho = \{\rho_{\alpha, \beta}\}_{\alpha, \beta \in \pi}$.

LEMMA 1.10. *Let $\lambda = (\lambda_\alpha)_{\alpha \in \pi} \in \Pi_{\alpha \in \pi} H_\alpha^*$. Then λ is a left π -integral for H if and only if $(\lambda_{\alpha^{-1}})_{\alpha \in \pi}$ is a coinvariant of H on H^\square (see Example 1.3).*

Proof. Suppose that λ is a left π -integral for H . Fix $\gamma \in \pi$. Let $\alpha, \beta \in \pi$ such that $\alpha\beta = \gamma$. We have that $\rho_{\alpha, \beta}(\lambda_{\gamma^{-1}}) = \lambda_{\alpha^{-1}} \otimes 1_\beta \in \overline{H_\alpha^*} \otimes H_\beta$ since $f\lambda_{\gamma^{-1}} = f(1_\beta)\lambda_{\alpha^{-1}}$ for all $f \in H_\beta^*$. Therefore $\lambda_{\gamma^{-1}} \in \cap_{\alpha\beta=\gamma} \rho_{\alpha, \beta}^{-1}(\overline{H_\alpha^*} \otimes H_\beta) = (H^*)_{\gamma^{-1}}^{\text{rat}} = H_\gamma^\square$, see Theorem 1.4(c). Hence, since $\rho_{\alpha, \beta}(\lambda_{(\alpha\beta)^{-1}}) = \lambda_{\alpha^{-1}} \otimes 1_\beta$ for all $\alpha, \beta \in \pi$, $(\lambda_{\alpha^{-1}})_{\alpha \in \pi}$ is a coinvariant of H on H^\square . Conversely, suppose that $(\lambda_{\alpha^{-1}})_{\alpha \in \pi}$ is a coinvariant of H on H^\square . Let $\alpha, \beta \in \pi$. Then $\rho_{(\alpha\beta)^{-1}, \alpha}(\lambda_\beta) = \lambda_{\alpha\beta} \otimes 1_\alpha$, i.e., $f\lambda_\beta = f(1_\alpha)\lambda_{\alpha\beta}$ for all $f \in H_\alpha^*$. Hence λ is a left π -integral for H . \square

For all $\alpha \in \pi$, we define a right H_α -module structure on H_α^\square by setting

$$(f \leftarrow a)(x) = f(xS_\alpha(a))$$

for any $f \in H_\alpha^\square$, $a \in H_\alpha$, and $x \in H_{\alpha^{-1}}$.

LEMMA 1.11. *H^\square is a right Hopf π -comodule over H .*

Proof. Let us first show that for any $\alpha, \beta \in \pi$, $f \in H_{\alpha\beta}^\square$, $a \in H_{\alpha\beta}$, and $g \in H_\beta^*$,

$$(1.13) \quad g(f \leftarrow a) = f_{(0, \alpha)} \leftarrow a_{(1, \alpha)} \langle g, f_{(1, \beta)} a_{(2, \beta)} \rangle,$$

where $\langle \cdot, \cdot \rangle$ denotes the natural pairing between H_β^* and H_β . Remark first that

$$\begin{aligned} 1_\beta \otimes S_{\alpha\beta}(a) &= \varepsilon(a_{(2, 1)}) 1_\beta \otimes S_{\alpha\beta}(a_{(1, \alpha\beta)}) \quad \text{by (1.2)} \\ &= S_{\beta^{-1}}(a_{(2, \beta^{-1})}) a_{(3, \beta)} \otimes S_{\alpha\beta}(a_{(1, \alpha\beta)}) \quad \text{by (1.5)} \\ &= S_\alpha(a_{(1, \alpha)})_{(1, \beta)} a_{(2, \beta)} \otimes S_\alpha(a_{(1, \alpha)})_{(2, (\alpha\beta)^{-1})} \quad \text{by Lemma 1.1(c)}. \end{aligned}$$

Then, for all $x \in H_{\alpha^{-1}}$,

$$\begin{aligned} x_{(1, \beta)} \otimes x_{(2, (\alpha\beta)^{-1})} S_{\alpha\beta}(a) &= x_{(1, \beta)} S_\alpha(a_{(1, \alpha)})_{(1, \beta)} a_{(2, \beta)} \otimes x_{(2, (\alpha\beta)^{-1})} S_\alpha(a_{(1, \alpha)})_{(2, (\alpha\beta)^{-1})} \\ &= (xS_\alpha(a_{(1, \alpha)}))_{(1, \beta)} a_{(2, \beta)} \otimes (xS_\alpha(a_{(1, \alpha)}))_{(2, (\alpha\beta)^{-1})} \quad \text{by (1.4)}, \end{aligned}$$

and so

$$\begin{aligned}
g(f \leftarrow a)(x) &= \langle g, x_{(1,\beta)} \rangle \langle f \leftarrow a, x_{(2,(\alpha\beta)^{-1})} \rangle \\
&= \langle g, x_{(1,\beta)} \rangle \langle f, x_{(2,(\alpha\beta)^{-1})} S_{\alpha\beta}(a) \rangle \\
&= \langle g, (xS_\alpha(a_{(1,\alpha)}))_{(1,\beta)} a_{(2,\beta)} \rangle \langle f, (xS_\alpha(a_{(1,\alpha)}))_{(2,(\alpha\beta)^{-1})} \rangle \\
&= ((a_{(2,\beta)} \rightarrow g)f) \leftarrow a_{(1,\alpha)}(x),
\end{aligned}$$

where \rightarrow is the left H_β -action on H_β^* defined by $(b \rightarrow l)(y) = l(yb)$ for any $l \in H_\beta^*$ and $b, y \in H_\beta$. Then

$$\begin{aligned}
g(f \leftarrow a) &= ((a_{(2,\beta)} \rightarrow g)f) \leftarrow a_{(1,\alpha)} \\
&= (f_{(0,\alpha)} \langle a_{(2,\beta)} \rightarrow g, f_{(1,\beta)} \rangle) \leftarrow a_{(1,\alpha)} \quad \text{by definition of } \rho_{\alpha,\beta} \\
&= f_{(0,\alpha)} \leftarrow a_{(1,\alpha)} \langle g, f_{(1,\beta)} a_{(2,\beta)} \rangle,
\end{aligned}$$

and hence (1.13) is proved.

Recall that the π -comodule structure map $\rho_{\alpha,\beta}$ of H^\square is, via the natural embedding $H_\alpha^\square \otimes H_\beta \subset \overline{H_\alpha^*} \otimes H_\beta \hookrightarrow \text{Hom}_{\mathbb{k}}(H_\beta^*, \overline{H_\alpha^*})$, the restriction onto $H_\alpha^\square \otimes H_\beta$ of the map $\xi_{\alpha,\beta} : H_\alpha^\square \rightarrow \text{Hom}_{\mathbb{k}}(H_\beta^*, \overline{H_\alpha^*})$ defined by $\xi_{\alpha,\beta}(f)(g) = gf$. Let $\gamma \in \pi$. By (1.13) we have that, for any $\alpha, \beta \in \pi$ such that $\alpha\beta = \gamma$, $f \in H_\gamma^\square$, and $a \in H_\gamma$,

$$\xi_{\alpha,\beta}(f \leftarrow a) = f_{(0,\alpha)} \leftarrow a_{(1,\alpha)} \otimes f_{(1,\beta)} a_{(2,\beta)} \in (H_\alpha^\square \leftarrow a_{(1,\alpha)}) \otimes H_\beta \subset \overline{H_\alpha^*} \otimes H_\beta.$$

Therefore, by Theorem 1.4(c), $f \leftarrow a \in \cap_{\alpha\beta=\gamma} \xi_{\alpha,\beta}^{-1}(\overline{H_\alpha^*} \otimes C_\beta) = H_\gamma^\square$. Hence the action of H_γ on H_γ^\square is well-defined. This is a right action because S_γ is unitary and anti-multiplicative (see Lemma 1.1). Finally, Axiom (1.11) is satisfied since (1.13) says that $\rho_{\alpha,\beta}(f \leftarrow a) = f_{(0,\alpha)} \leftarrow a_{(1,\alpha)} \otimes f_{(1,\beta)} a_{(2,\beta)}$ for any $\alpha, \beta \in \pi$, $f \in H_{\alpha\beta}^\square$, and $a \in H_{\alpha\beta}$. Thus H^\square is a right Hopf π -comodule over H . \square

By Theorem 1.8, the Hopf π -comodule H^\square is isomorphic to the Hopf π -comodule $(H^\square)^{\text{co}H} \otimes H$. Let $f = \{f_\alpha : (H^\square)_{\alpha}^{\text{co}H} \otimes H_\alpha \rightarrow H_\alpha^\square\}_{\alpha \in \pi}$ be the right Hopf π -comodule isomorphism between them as in the proof Theorem 1.8. Recall that $f_\alpha(m \otimes h) = m \leftarrow h$ for any $\alpha \in \pi$, $m \in (H^\square)_{\alpha}^{\text{co}H}$, and $h \in H_\alpha$.

LEMMA 1.12. *If there exists a non-zero left π -integral for H , then S_α is injective for all $\alpha \in \pi$.*

Proof. Suppose that $\lambda = (\lambda_\alpha)_{\alpha \in \pi}$ is a non-zero left π -integral for H . Let $\alpha \in \pi$. If $H_\alpha = 0$, then the result is obvious. Let us suppose that $H_\alpha \neq 0$. Then $H_{\alpha^{-1}} \neq 0$ by Corollary 1.2 and so $\lambda_{\alpha^{-1}} \neq 0$ by Lemma 1.9. Let $h \in H_\alpha$ such that $S_\alpha(h) = 0$. By Lemma 1.10, $\lambda_{\alpha^{-1}} \in H_{\alpha^{-1}}^{\text{co}H}$. Now $f_\alpha(\lambda_{\alpha^{-1}} \otimes h) = \lambda_{\alpha^{-1}} \leftarrow h = 0$ (since $S_\alpha(h) = 0$). Thus $\lambda_{\alpha^{-1}} \otimes h = 0$ (since f_α is an isomorphism) and so $h = 0$ (since $\lambda_{\alpha^{-1}} \neq 0$). \square

THEOREM 1.13. *Let $H = \{H_\alpha\}_{\alpha \in \pi}$ be a finite type Hopf π -coalgebra. Then the space of left (resp. right) π -integrals for H is one-dimensional.*

Proof. For any $\alpha, \beta \in \pi$, since H is of finite type and $\overline{H_\alpha^*} = H_{\alpha^{-1}}^*$, we have that $\dim \overline{H_\alpha^*} \otimes H_\beta = \dim \text{Hom}_{\mathbb{k}}(H_\beta^*, \overline{H_\alpha^*}) < +\infty$. Therefore the natural embedding $\overline{H_\alpha^*} \otimes H_\beta \hookrightarrow \text{Hom}_{\mathbb{k}}(H_\beta^*, \overline{H_\alpha^*})$ is an isomorphism. Thus H^* is a rational π -graded H^* -module (see §1.2.2) and so $H_\alpha^* = H_{\alpha^{-1}}^*$ for all $\alpha \in \pi$. Now $\dim(H^\square)_{\alpha}^{\text{co}H} = 1$ since $(H^\square)_{\alpha}^{\text{co}H} \otimes H_1 \cong H_1^\square$, $\dim H_1 = \dim H_1^\square < +\infty$, and $\dim H_1 \neq 0$ (since $1_1 \neq 0$ because $\varepsilon(1_1) = 1_{\mathbb{k}} \neq 0$). Hence there exists a π -coinvariant $(\psi_\alpha)_{\alpha \in \pi}$ of H on H^\square such that $\psi_1 \neq 0$. Set $\lambda_\alpha = \psi_{\alpha^{-1}}$ for any $\alpha \in \pi$. By Lemma 1.10, $\lambda = (\lambda_\alpha)_{\alpha \in \pi}$ is a left π -integral for H . Moreover $\lambda_1 = \psi_1 \neq 0$ and so λ is non-zero.

Suppose now that $\delta = (\delta_\alpha)_{\alpha \in \pi}$ is another left π -integral for H . Let $\alpha \in \pi$ such that $H_\alpha \neq 0$. By Lemma 1.12, S_α and $S_{\alpha^{-1}}$ are injective (since there exists a non-zero left integral for H) and so $\dim H_\alpha = \dim H_{\alpha^{-1}}$. Therefore $\dim(H^\square)_{\alpha}^{\text{co}H} = 1$ since $(H^\square)_{\alpha}^{\text{co}H} \otimes H_\alpha \cong H_\alpha^\square$ and $0 \neq \dim H_\alpha =$

$\dim H_\alpha^\square < +\infty$. Now $\lambda_{\alpha^{-1}}, \delta_{\alpha^{-1}} \in (H^\square)_{\alpha^{-1}}^{\text{co}H}$ by Lemma 1.10 and $\lambda_{\alpha^{-1}} \neq 0$ (by Lemma 1.9). Hence there exists $k_\alpha \in \mathbb{k}$ such that $\delta_{\alpha^{-1}} = k_\alpha \lambda_{\alpha^{-1}}$. If $\alpha \in \pi$ is such that $H_\alpha \neq 0$, then

$$k_1 \lambda_1 1_\alpha = \delta_1 1_\alpha = (\text{id}_{H_\alpha} \otimes \delta_{\alpha^{-1}}) \Delta_{\alpha, \alpha^{-1}} = k_\alpha (\text{id}_{H_\alpha} \otimes \lambda_{\alpha^{-1}}) \Delta_{\alpha, \alpha^{-1}} = k_\alpha \lambda_1 1_\alpha,$$

and thus $k_\alpha = k_1$ (since $\lambda_1 \neq 0$ and $1_\alpha \neq 0$). If $\alpha \in \pi$ is such that $H_\alpha = 0$, then $\delta_\alpha = 0 = \lambda_\alpha$ and so $\delta_\alpha = k_1 \lambda_\alpha$. Hence we can conclude that δ is a scalar multiple of λ .

To show the existence and the uniqueness of right π -integrals for H , it suffices to consider the opposite and coopposite Hopf π -coalgebra $H^{\text{op}, \text{cop}}$ to H (see §1.1.3.3). Indeed $\lambda = (\lambda_\alpha)_{\alpha \in \pi} \in \prod_{\alpha \in \pi} H_\alpha^*$ is a right π -integral for H if and only if $(\lambda_{\alpha^{-1}})_{\alpha \in \pi}$ is a left π -integral for $H^{\text{op}, \text{cop}}$. This completes the proof of the theorem. \square

COROLLARY 1.14. *Let $H = \{H_\alpha\}_{\alpha \in \pi}$ be a finite type Hopf π -coalgebra. Then*

- (a) *The antipode $S = \{S_\alpha\}_{\alpha \in \pi}$ of H is bijective.*
- (b) *Let $\alpha \in \pi$. Then H_α^* is a free left (resp. right) H_α -module for the action defined, for any $f \in H_\alpha^*$ and $a, x \in H_\alpha$, by*

$$(a \rightharpoonup f)(x) = f(xa) \quad (\text{resp. } (f \leftarrow a)(x) = f(ax)).$$

Its rank is 1 if $H_\alpha \neq 0$ and 0 otherwise. Moreover, if $\lambda = (\lambda_\beta)_{\beta \in \pi}$ is a non-zero left (resp. right) π -integral for H , then λ_α is a basis vector for H_α^ .*

Proof. To show Part (a), let $\alpha \in \pi$. By Lemma 1.12 and Theorem 1.13, $S_\alpha : H_\alpha \rightarrow H_{\alpha^{-1}}$ and $S_{\alpha^{-1}} : H_{\alpha^{-1}} \rightarrow H_\alpha$ are injective. Thus $\dim H_\alpha = \dim H_{\alpha^{-1}}$ and so S_α is bijective. To show Part (b), let $\lambda = (\lambda_\alpha)_{\alpha \in \pi}$ be a non-zero left π -integral for H and fix $\alpha \in \pi$. If $H_\alpha = 0$, then the result is obvious. Let us suppose that $H_\alpha \neq 0$. Recall that $H_{\alpha^{-1}}^\square = H_\alpha^*$ and $f_{\alpha^{-1}} : (H^*)_{\alpha^{-1}}^{\text{co}H} \otimes H_{\alpha^{-1}} \rightarrow H_\alpha^*$ defined by $f \otimes h \mapsto S_{\alpha^{-1}}(h) \rightharpoonup f$ is an isomorphism. Since $0 \neq \lambda_\alpha \in (H^*)_{\alpha^{-1}}^{\text{co}H}$, $\dim(H^*)_{\alpha^{-1}}^{\text{co}H} = 1$, and $S_{\alpha^{-1}}$ is bijective, the map $H_\alpha \rightarrow H_\alpha^*$ defined by $h \mapsto h \rightharpoonup \lambda_\alpha$ is an isomorphism. Thus $(H_\alpha^*, \rightharpoonup)$ is a free left H_α -module of rank 1 with vector basis λ_α . Using $H^{\text{op}, \text{cop}}$ (see §1.1.3.3), one easily deduces the right case. \square

1.4. The distinguished π -grouplike element

In this section, we extend the notion of a grouplike element of a Hopf algebra to the setting of a Hopf π -coalgebra. We show that a π -grouplike element is distinguished in a finite type Hopf π -coalgebra and we study its relations with the π -integrals. As a corollary, for any $\alpha \in \pi$ of finite order, we give an upper bound for the (finite) order of $S_{\alpha^{-1}} S_\alpha$.

1.4.1. π -grouplike elements. A π -grouplike element of a Hopf π -coalgebra $H = \{H_\alpha\}_{\alpha \in \pi}$ is a family $g = (g_\alpha)_{\alpha \in \pi} \in \prod_{\alpha \in \pi} H_\alpha$ such that $\Delta_{\alpha, \beta}(g_{\alpha\beta}) = g_\alpha \otimes g_\beta$ for any $\alpha, \beta \in \pi$ and $\varepsilon(g_1) = 1_{\mathbb{k}}$ (or equivalently $g_1 \neq 0$). Note that g_1 is then a (usual) grouplike element of the Hopf algebra H_1 .

One easily checks that the set $G(H)$ of π -grouplike elements of H is a group (with respect to the multiplication and unit of the product monoid $\prod_{\alpha \in \pi} H_\alpha$) and if $g = (g_\alpha)_{\alpha \in \pi} \in G(H)$, then $g^{-1} = (S_{\alpha^{-1}}(g_{\alpha^{-1}}))_{\alpha \in \pi}$.

We remark that the group $\text{Hom}(\pi, \mathbb{k}^*)$ acts on $G(H)$ by $\phi g = (\phi(\alpha) g_\alpha)_{\alpha \in \pi}$ for any $g = (g_\alpha)_{\alpha \in \pi} \in G(H)$ and $\phi \in \text{Hom}(\pi, \mathbb{k}^*)$.

LEMMA 1.15. *Let $H = \{H_\alpha\}_{\alpha \in \pi}$ be a finite type Hopf π -coalgebra. Then there exists a unique π -grouplike element $g = (g_\alpha)_{\alpha \in \pi}$ of H such that $(\text{id}_{H_\alpha} \otimes \lambda_\beta) \Delta_{\alpha, \beta} = \lambda_{\alpha\beta} g_\alpha$ for any right π -integral $\lambda = (\lambda_\alpha)_{\alpha \in \pi}$ and all $\alpha, \beta \in \pi$.*

The π -grouplike element $g = (g_\alpha)_{\alpha \in \pi}$ of the previous lemma is called the *distinguished π -grouplike element of H* . Note that g_1 is the (usual) distinguished grouplike element of the Hopf algebra H_1 .

Proof. Let $\lambda = (\lambda_\alpha)_{\alpha \in \pi}$ be a non-zero right π -integral for H . Let $\gamma \in \pi$. For any $\varphi \in H_\gamma^*$, $(\varphi \lambda_{\gamma^{-1}\alpha})_{\alpha \in \pi}$ is a right π -integral for H and thus, by Theorem 1.13, there exists a unique $k_\varphi \in \mathbb{k}$ such that $\varphi \lambda_{\gamma^{-1}\alpha} = k_\varphi \lambda_\alpha$ for all $\alpha \in \pi$. Now $(\varphi \mapsto k_\varphi) \in H_\gamma^{**} \cong H_\gamma$ ($\dim H_\gamma < +\infty$). Therefore there exists a unique $g_\gamma \in H_\gamma$ such that $\varphi \lambda_{\gamma^{-1}\alpha} = \varphi(g_\gamma) \lambda_\alpha$ for any $\alpha \in \pi$ and $\varphi \in H_\gamma^*$. Then $\varphi \lambda_\beta = \varphi(g_\alpha) \lambda_{\alpha\beta}$ for any $\alpha, \beta \in \pi$ and $\varphi \in H_\alpha^*$ and hence $(\text{id}_{H_\alpha} \otimes \lambda_\beta) \Delta_{\alpha,\beta} = \lambda_{\alpha\beta} g_\alpha$ for all $\alpha, \beta \in \pi$. Let $\alpha, \beta \in \pi$. If $H_{\alpha\beta} = 0$, then either $H_\alpha = 0$ or $H_\beta = 0$ (by Corollary 1.2) and so $\Delta_{\alpha,\beta}(g_{\alpha\beta}) = 0 = g_\alpha \otimes g_\beta$. If $H_{\alpha\beta} \neq 0$ then, for any $\varphi \in H_\alpha^*$ and $\psi \in H_\beta^*$, $k_{\varphi\psi} \lambda_{\alpha\beta} = (\varphi\psi) \lambda_1 = \varphi(\psi \lambda_1) = k_\psi \varphi \lambda_\beta = k_\varphi k_\psi \lambda_{\alpha\beta}$ and thus $k_{\varphi\psi} = k_\varphi k_\psi$ (since $\lambda_{\alpha\beta} \neq 0$ by Lemma 1.9), that is $\Delta_{\alpha,\beta}(g_{\alpha\beta}) = g_\alpha \otimes g_\beta$. Moreover $\varepsilon(g_1) \lambda_1 = (\varepsilon \otimes \lambda_1) \Delta_{1,1} = \lambda_1$ and so $\varepsilon(g_1) = 1$ (since $\lambda_1 \neq 0$ by Lemma 1.9). Then $g = (g_\alpha)_{\alpha \in \pi}$ is a π -grouplike element of H . Since all the right π -integrals for H are scalar multiple of λ , the ‘‘existence’’ part of the lemma is proved. Let us now show the uniqueness of g . Suppose that $h = (h_\alpha)_{\alpha \in \pi}$ is another such π -grouplike element of H . Let $\lambda = (\lambda_\alpha)_{\alpha \in \pi}$ be a non-zero right π -integral for H . Fix $\alpha \in \pi$. If $H_\alpha = 0$, then $h_\alpha = 0 = g_\alpha$. If $H_\alpha \neq 0$, then $\lambda_\alpha \neq 0$ (by Lemma 1.9) and so there exists $a \in H_\alpha$ such that $\lambda_\alpha(a) = 1$. Therefore $g_\alpha = \lambda_\alpha(a) g_\alpha = (\text{id}_{H_\alpha} \otimes \lambda_1) \Delta_{\alpha,1}(a) = \lambda_\alpha(a) h_\alpha = h_\alpha$. This completes the proof of the lemma. \square

1.4.2. The distinguished π -grouplike element and π -integrals. Throughout this subsection, $H = \{H_\alpha\}_{\alpha \in \pi}$ will denote a finite type Hopf π -coalgebra.

Since H_1 is a finite-dimensional Hopf algebra, there exists (e.g., see [37]) a unique algebra morphism $\nu : H_1 \rightarrow \mathbb{k}$ such that if Λ is a left integral for H_1 , then $\Lambda x = \nu(x) \Lambda$ for all $x \in H_1$. This morphism is a grouplike element of the Hopf algebra H_1^* , called the *distinguished grouplike element of H_1^** . In particular, it is invertible in H_1^* and its inverse ν^{-1} is also an algebra morphism and verifies that if Λ is a right integral for H_1 , then $x \Lambda = \nu^{-1}(x) \Lambda$ for all $x \in H_1$.

For all $\alpha \in \pi$, we define a left and a right H_1^* -action on H_α by setting, for any $f \in H_1^*$ and $a \in H_\alpha$,

$$f \rightharpoonup a = a_{(1,\alpha)} f(a_{(2,1)}) \quad \text{and} \quad a \leftarrow f = f(a_{(1,1)}) a_{(2,\alpha)}.$$

The next theorem generalizes [39, THEOREM 3]. It is used in Section 2.2 to show the existence of traces.

THEOREM 1.16. *Let $\lambda = (\lambda_\alpha)_{\alpha \in \pi}$ be a right π -integral for H , $g = (g_\alpha)_{\alpha \in \pi}$ be the distinguished π -grouplike element of H , and ν be the distinguished grouplike element of H_1^* . Then, for any $\alpha \in \pi$ and $x, y \in H_\alpha$,*

- (a) $\lambda_\alpha(xy) = \lambda_\alpha(S_{\alpha^{-1}} S_\alpha(y \leftarrow \nu)x)$;
- (b) $\lambda_\alpha(xy) = \lambda_\alpha(y S_{\alpha^{-1}} S_\alpha(\nu^{-1} \rightarrow g_\alpha^{-1} x g_\alpha))$;
- (c) $\lambda_{\alpha^{-1}}(S_\alpha(x)) = \lambda_\alpha(g_\alpha x)$.

Before proving Theorem 1.16, we establish the following lemma.

LEMMA 1.17. *Let $\lambda = (\lambda_\alpha)_{\alpha \in \pi}$ be a right π -integral for H , $\alpha \in \pi$, and $a \in H_\alpha$.*

- (a) *If Λ is a right integral for H_1 such that $\lambda_1(\Lambda) = 1$, then*

$$S_\alpha(a) = \lambda_\alpha(\Lambda_{(1,\alpha)} a) \Lambda_{(2,\alpha^{-1})};$$

- (b) *If Λ is a left integral for H_1 such that $\lambda_1(\Lambda) = 1$, then*

$$S_{\alpha^{-1}}^{-1}(a) = \lambda_\alpha(a \Lambda_{(1,\alpha)}) \Lambda_{(2,\alpha^{-1})}.$$

Proof. To show Part (a), let $\alpha \in \pi$. Define $f \in H_\alpha^*$ by $f(x) = \lambda_\alpha(\Lambda_{(1,\alpha)} x) \Lambda_{(2,\alpha^{-1})}$ for any $x \in H_\alpha$. If $*$ denotes the product in the convolution algebra $\text{Conv}(H, H_{\alpha^{-1}})$ (see §1.1.2), then, for any $x \in H_1$,

$$\begin{aligned} (f * \text{id}_{H_{\alpha^{-1}}})(x) &= \lambda_\alpha(\Lambda_{(1,\alpha)} x_{(1,\alpha)}) \Lambda_{(2,\alpha^{-1})} x_{(2,\alpha^{-1})} \\ &= \lambda_\alpha((\Lambda x)_{(1,\alpha)}) (\Lambda x)_{(2,\alpha^{-1})} \quad \text{by (1.4)} \end{aligned}$$

$$\begin{aligned}
&= \varepsilon(x) \lambda_\alpha(\Lambda_{(1,\alpha)}) \Lambda_{(2,\alpha^{-1})} \quad \text{since } \Lambda \text{ is a right integral for } H_1 \\
&= \varepsilon(x) \lambda_1(\Lambda) 1_{\alpha^{-1}} \quad \text{by (1.12)} \\
&= \varepsilon(x) 1_{\alpha^{-1}} \quad \text{since } \lambda_1(\Lambda) = 1.
\end{aligned}$$

Therefore, since $\text{id}_{H_{\alpha^{-1}}}$ is invertible in $\text{Conv}(H, H_{\alpha^{-1}})$ with inverse S_α , we have that $f = S_\alpha$, that is $S_\alpha(a) = \lambda_\alpha(\Lambda_{(1,\alpha)}a) \Lambda_{(2,\alpha^{-1})}$ for all $a \in H_\alpha$. Part (b) can be deduced from Part (a) by using the Hopf π -coalgebra H^{op} (see §1.1.3.1). \square

Proof of Theorem 1.16. We use the same arguments as in the proof of [39, THEOREM 3], even if we cannot use the duality (since the notion a Hopf π -coalgebra is not self dual). We can assume that λ is a non-zero right π -integral (otherwise the result is obvious). To show Part (a), let $\alpha \in \pi$ and $x, y \in H_\alpha$. Since λ_1 is a non-zero right integral for the Hopf algebra H_1^* , there exists a left integral Λ for H_1 such that $\lambda_1(\Lambda) = \lambda_1(S_1(\Lambda)) = 1$ (cf [39, PROPOSITION 1]). By Lemma 1.17(b) for $a = S_{\alpha^{-1}}S_\alpha(y \leftarrow v)$, we have that

$$(1.14) \quad S_\alpha(y \leftarrow v) = \lambda_\alpha(S_{\alpha^{-1}}S_\alpha(y \leftarrow v) \Lambda_{(1,\alpha)}) \Lambda_{(2,\alpha^{-1})}.$$

It is easy to verify that $(v^{-1}\lambda_\gamma)_{\gamma \in \pi}$ is a right π -integral for H and $\Lambda \leftarrow v$ is a right integral for H_1 such that $(v^{-1}\lambda_1)(\Lambda \leftarrow v) = 1$. Thus Lemma 1.17(a) for $a = y \leftarrow v$ gives that

$$\begin{aligned}
S_\alpha(y \leftarrow v) &= (v^{-1}\lambda_\alpha)((\Lambda \leftarrow v)_{(1,\alpha)}(y \leftarrow v))(\Lambda \leftarrow v)_{(2,\alpha^{-1})} \\
&= (v^{-1}\lambda_\alpha)((\Lambda_{(1,\alpha)}y) \leftarrow v) \Lambda_{(2,\alpha^{-1})} \quad \text{by (1.4)} \\
&= \lambda_\alpha(((\Lambda_{(1,\alpha)}y) \leftarrow v) \leftarrow v^{-1}) \Lambda_{(2,\alpha^{-1})} \\
&= \lambda_\alpha((\Lambda_{(1,\alpha)}y) \leftarrow \varepsilon) \Lambda_{(2,\alpha^{-1})} \\
&= \lambda_\alpha(\Lambda_{(1,\alpha)}y) \Lambda_{(2,\alpha^{-1})} \quad \text{by (1.2)}.
\end{aligned}$$

Hence, by comparing with (1.14), we obtain that

$$(1.15) \quad \lambda_\alpha(\Lambda_{(1,\alpha)}y) \Lambda_{(2,\alpha^{-1})} = \lambda_\alpha(S_{\alpha^{-1}}S_\alpha(y \leftarrow v) \Lambda_{(1,\alpha)}) \Lambda_{(2,\alpha^{-1})}.$$

Now $(\lambda_\gamma S_{\gamma^{-1}})_{\gamma \in \pi}$ is a right π -integral for H^{cop} and Λ is a left integral for H_1^{cop} with $(\lambda_1 S_1)(\Lambda) = 1$. Thus, applying Lemma 1.17(b) for $a = S_{\alpha^{-1}}^{-1}(x) \in H_\alpha^{\text{cop}}$, we get

$$(S_{\alpha^{-1}}^{\text{cop}})^{-1}(S_{\alpha^{-1}}^{-1}(x)) = \lambda_\alpha S_{\alpha^{-1}}(S_{\alpha^{-1}}^{-1}(x) \Lambda_{(2,\alpha^{-1})}) \Lambda_{(1,\alpha)},$$

that is

$$(1.16) \quad x = \Lambda_{(1,\alpha)} \lambda_\alpha(S_{\alpha^{-1}}(\Lambda_{(2,\alpha^{-1})}x)).$$

Finally, evaluating (1.15) with $\lambda_\alpha(S_{\alpha^{-1}}(\cdot)x)$ and using (1.16) gives $\lambda_\alpha(xy) = \lambda_\alpha(S_{\alpha^{-1}}S_\alpha(y \leftarrow v)x)$.

To show Part (b), let $\alpha \in \pi$ and $a, b \in H_\alpha$. For any $\gamma \in \pi$, let us define $\phi_\gamma \in (H_\gamma^{\text{op,cop}})^*$ by $\phi_\gamma(x) = \lambda_{\gamma^{-1}}(g_{\gamma^{-1}}x)$ for all $x \in H_\gamma^{\text{op,cop}}$. Using Lemma 1.15, one easily checks that $\phi = (\phi_\gamma)_{\gamma \in \pi}$ is a right π -integral for $H^{\text{op,cop}}$. Let us denote by \times^{op} the multiplication of $H_{\alpha^{-1}}^{\text{op,cop}}$ and by \leftarrow^{cop} the right action of $(H_1^{\text{op,cop}})^*$ on $H_{\alpha^{-1}}^{\text{op,cop}}$ defined by $h \leftarrow^{\text{cop}} f = (f \otimes \text{id})\Delta_{1,\alpha^{-1}}^{\text{cop}}(h)$. Then, since v^{-1} is the distinguished grouplike element of $(H_1^{\text{op,cop}})^*$, Part (a) with $x = g_\alpha^{-1}b$ and $y = g_\alpha^{-1}ag_\alpha$ gives that $\phi_{\alpha^{-1}}(x \times^{\text{op}} y) = \phi_{\alpha^{-1}}(S_\alpha^{\text{op,cop}} S_{\alpha^{-1}}^{\text{op,cop}}(y \leftarrow^{\text{cop}} v^{-1}) \times^{\text{op}} x)$, that is $\lambda_\alpha(ab) = \lambda_\alpha(b S_{\alpha^{-1}} S_\alpha(v^{-1} \leftarrow g_\alpha^{-1}ag_\alpha))$.

Let us show Part (c). For any $\alpha \in \pi$, define $\phi_\alpha \in H_\alpha^*$ by $\phi_\alpha(x) = \lambda_\alpha(g_\alpha x)$ for all $x \in H_\alpha$. Since $(\phi_\alpha)_{\alpha \in \pi}$ and $(\lambda_{\alpha^{-1}} S_\alpha)_{\alpha \in \pi}$ are left π -integrals for H which are non-zero (because λ is non-zero, g is invertible, and S is bijective), there exists $k \in \mathbb{k}$ such that $\phi_\alpha = k \lambda_{\alpha^{-1}} S_\alpha$ for all $\alpha \in \pi$ (by Theorem 1.13). As above, let Λ be a left integral for H_1 such that $\lambda_1(\Lambda) = \lambda_1(S_1(\Lambda)) = 1$. Recall that $\varepsilon(g_1) = 1$. Then $1 = \lambda_1(\Lambda) = \lambda_1(\varepsilon(g_1)\Lambda) = \lambda_1(g_1\Lambda) = k \lambda_1(S_1(\Lambda)) = k$. Hence $\lambda_{\alpha^{-1}} S_\alpha = \phi_\alpha$

for all $\alpha \in \pi$, that is $\lambda_{\alpha^{-1}}(S_\alpha(x)) = \lambda_\alpha(g_\alpha x)$ for all $\alpha \in \pi$ and $x \in H_\alpha$. This completes the proof of the theorem. \square

The following corollary will be used later to relate the distinguished grouplike element of a finite type quasitriangular Hopf π -coalgebra to the R -matrix.

COROLLARY 1.18. *Let Λ be a left integral for H_1 and $g = (g_\alpha)_{\alpha \in \pi}$ be the distinguished π -grouplike element of H . Then, for all $\alpha \in \pi$,*

$$\Lambda_{(1,\alpha)} \otimes \Lambda_{(2,\alpha^{-1})} = S_{\alpha^{-1}} S_\alpha(\Lambda_{(2,\alpha)}) g_\alpha \otimes \Lambda_{(1,\alpha^{-1})}.$$

Proof. We can suppose that $\Lambda \neq 0$. Let $\alpha \in \pi$. Remark that it suffices to show that, for all $f \in H_{\alpha^{-1}}^*$,

$$(1.17) \quad f(\Lambda_{(2,\alpha^{-1})}) \Lambda_{(1,\alpha)} = f(\Lambda_{(1,\alpha^{-1})}) S_{\alpha^{-1}} S_\alpha(\Lambda_{(2,\alpha)}) g_\alpha.$$

Fix $f \in H_{\alpha^{-1}}^*$. Let $\lambda = (\lambda_\gamma)_{\gamma \in \pi}$ be a non-zero right π -integral for H (see Theorem 1.13). By multiplying λ by some (non-zero) scalar, we can assume that $\lambda_1(\Lambda) = \lambda_1(S_1(\Lambda)) = 1$. By Corollary 1.14(b), there exists $a \in H_{\alpha^{-1}}$ such that $f(x) = \lambda_{\alpha^{-1}}(ax)$ for all $x \in H_{\alpha^{-1}}$. By Lemma 1.17(b), $S_{\alpha^{-1}}(a) = \lambda_{\alpha^{-1}}(a\Lambda_{(1,\alpha^{-1})}) S_{\alpha^{-1}} S_\alpha(\Lambda_{(2,\alpha)})$. Thus

$$(1.18) \quad S_{\alpha^{-1}}(a) g_\alpha = f(\Lambda_{(1,\alpha^{-1})}) S_{\alpha^{-1}} S_\alpha(\Lambda_{(2,\alpha)}) g_\alpha.$$

Since $(\lambda_\gamma S_{\gamma^{-1}})_{\gamma \in \pi}$ is a right π -integral for $H^{\text{op,cop}}$ and Λ is a right integral for $H_1^{\text{op,cop}}$ such that $(\lambda_1 S_1)(\Lambda) = 1$, Lemma 1.17(a) applied to $H^{\text{op,cop}}$ gives that

$$S_{\alpha^{-1}}(a) = \lambda_\alpha S_{\alpha^{-1}}(a\Lambda_{(2,\alpha^{-1})}) \Lambda_{(1,\alpha)}.$$

Then, by using Theorem 1.16(c), we get

$$(1.19) \quad \begin{aligned} S_{\alpha^{-1}}(a) g_\alpha &= \lambda_\alpha S_{\alpha^{-1}}(a\Lambda_{(2,\alpha^{-1})}) \Lambda_{(1,\alpha)} g_\alpha \\ &= \lambda_{\alpha^{-1}}(g_{\alpha^{-1}} a \Lambda_{(2,\alpha^{-1})}) \Lambda_{(1,\alpha)} g_\alpha. \end{aligned}$$

Now, since Λ is left integral for H_1 ,

$$\Lambda_{(1,\alpha)} g_\alpha \otimes \Lambda_{(2,\alpha^{-1})} g_{\alpha^{-1}} = \Delta_{\alpha,\alpha^{-1}}(\Lambda g_1) = \nu(g_1) \Lambda_{(1,\alpha)} \otimes \Lambda_{(2,\alpha^{-1})}.$$

Therefore

$$\Lambda_{(1,\alpha)} g_\alpha \otimes g_{\alpha^{-1}} a \Lambda_{(2,\alpha^{-1})} = \Lambda_{(1,\alpha)} \otimes \nu(g_1) g_{\alpha^{-1}} a \Lambda_{(2,\alpha^{-1})} g_{\alpha^{-1}}^{-1},$$

and so, using (1.19) and then Theorem 1.16(a),

$$\begin{aligned} S_{\alpha^{-1}}(a) g_\alpha &= \lambda_{\alpha^{-1}}(\nu(g_1) g_{\alpha^{-1}} a \Lambda_{(2,\alpha^{-1})} g_{\alpha^{-1}}^{-1}) \Lambda_{(1,\alpha)} \\ &= \lambda_{\alpha^{-1}}(\nu(g_1) S_\alpha S_{\alpha^{-1}}(g_{\alpha^{-1}}^{-1} \leftarrow \nu) g_{\alpha^{-1}} a \Lambda_{(2,\alpha^{-1})}) \Lambda_{(1,\alpha)}. \end{aligned}$$

Now $S_\alpha S_{\alpha^{-1}}(g_{\alpha^{-1}}^{-1} \leftarrow \nu) = \nu(g_1)^{-1} g_{\alpha^{-1}}^{-1}$ since $g^{-1} = (g_\beta^{-1} = S_{\beta^{-1}}(g_{\beta^{-1}}))_{\beta \in \pi}$ is a π -grouplike element and ν is an algebra morphism. Thus

$$S_{\alpha^{-1}}(a) g_\alpha = \lambda_{\alpha^{-1}}(a \Lambda_{(2,\alpha^{-1})}) \Lambda_{(1,\alpha)} = f(\Lambda_{(2,\alpha^{-1})}) \Lambda_{(1,\alpha)}.$$

Finally, by comparing the last equation with (1.18), we get (1.17). \square

1.4.3. The order of the antipode. It is known that the order of the antipode of a finite-dimensional Hopf algebra A is finite (by [37, THEOREM 1]) and divides $4 \dim A$ (by [33, PROPOSITION 3.1]). Let us apply this result to the setting of a Hopf π -coalgebra.

Let $H = \{H_\alpha\}_{\alpha \in \pi}$ be a finite type Hopf π -coalgebra with antipode $S = \{S_\alpha\}_{\alpha \in \pi}$. Let $\alpha \in \pi$ of finite order d and denote by $\langle \alpha \rangle$ the subgroup of π generated by α . By considering the (finite-dimensional) Hopf algebra $\bigoplus_{\beta \in \langle \alpha \rangle} H_\beta$ (coming from the Hopf $\langle \alpha \rangle$ -coalgebra $\{H_\beta\}_{\beta \in \langle \alpha \rangle}$, as in §1.1.3.5), we obtain that the order of $S_{\alpha^{-1}}S_\alpha \in \text{Aut}_{\text{Alg}}(H_\alpha)$ is finite and divides $2 \sum_{\beta \in \langle \alpha \rangle} \dim H_\beta$. As a corollary of Theorem 1.16, we give another upper bound for the order of $S_{\alpha^{-1}}S_\alpha$.

COROLLARY 1.19. *Let $H = \{H_\alpha\}_{\alpha \in \pi}$ be a finite type Hopf π -coalgebra with antipode $S = \{S_\alpha\}_{\alpha \in \pi}$. If $\alpha \in \pi$ has a finite order d , then $(S_{\alpha^{-1}}S_\alpha)^{2d \dim H_1} = \text{id}_{H_\alpha}$.*

Note that if $\alpha \in \pi$ has order 2, then Corollary 1.19 gives that $S_\alpha^{8 \dim H_1} = \text{id}_{H_\alpha}$, since in this case S_α is an endomorphism of H_α .

Before proving Corollary 1.19, we establish the following lemma.

LEMMA 1.20. *Let $H = \{H_\alpha\}_{\alpha \in \pi}$ be a finite type Hopf π -coalgebra, $g = (g_\alpha)_{\alpha \in \pi}$ be the distinguished π -grouplike element of H , and ν be the distinguished grouplike element of H_1^* . Then*

$$(S_{\alpha^{-1}}S_\alpha)^2(x) = g_\alpha(\nu \rightharpoonup x \leftarrow \nu^{-1})g_\alpha^{-1}$$

for all $\alpha \in \pi$ and $x \in H_\alpha$.

Proof. Let $\alpha \in \pi$ and $x, y \in H_\alpha$. If $H_\alpha = 0$, then the result is obvious. Let us suppose that $H_\alpha \neq 0$. Let $\lambda = (\lambda_\gamma)_{\gamma \in \pi}$ be a non-zero right π -integral for H . Then

$$\begin{aligned} & \lambda_\alpha(g_\alpha(\nu \rightharpoonup x \leftarrow \nu^{-1})g_\alpha^{-1}y) \\ &= \lambda_\alpha(yS_{\alpha^{-1}}S_\alpha(\nu^{-1} \rightharpoonup g_\alpha^{-1}g_\alpha(\nu \rightharpoonup x \leftarrow \nu^{-1})g_\alpha^{-1}g_\alpha)) \quad \text{by Theorem 1.16(b)} \\ &= \lambda_\alpha(yS_{\alpha^{-1}}S_\alpha(x \leftarrow \nu^{-1})) \\ &= \lambda_\alpha(S_{\alpha^{-1}}S_\alpha(S_{\alpha^{-1}}S_\alpha(x \leftarrow \nu^{-1}) \leftarrow \nu)y) \quad \text{by Theorem 1.16(a)} \\ &= \lambda_\alpha((S_\alpha S_{\alpha^{-1}})^2(x \leftarrow \nu^{-1} \leftarrow \nu)y) \quad \text{since } S_{\alpha^{-1}}S_\alpha \text{ is comultiplicative} \\ &= \lambda_\alpha((S_\alpha S_{\alpha^{-1}})^2(x \leftarrow \varepsilon)y) \\ &= \lambda_\alpha((S_\alpha S_{\alpha^{-1}})^2(x)y). \end{aligned}$$

Now, by Corollary 1.14(b), H_α^* is a free right H_α -module of rank 1 for the action defined by $(f \triangleleft a)(x) = f(ax)$ for any $f \in H_\alpha^*$ and $a, x \in H_\alpha$, and λ_α is a basis vector of $(H_\alpha^*, \triangleleft)$. Thus, since the above computation says that

$$\lambda_\alpha \triangleleft g_\alpha(\nu \rightharpoonup x \leftarrow \nu^{-1})g_\alpha^{-1} = \lambda_\alpha \triangleleft (S_\alpha S_{\alpha^{-1}})^2(x),$$

we conclude that $(S_{\alpha^{-1}}S_\alpha)^2(x) = g_\alpha(\nu \rightharpoonup x \leftarrow \nu^{-1})g_\alpha^{-1}$. \square

Proof of Corollary 1.19. Let $\alpha \in \pi$ of finite order d . Consider the distinguished π -grouplike element $g = (g_\alpha)_{\alpha \in \pi}$ of H and the distinguished grouplike element ν of H_1^* . Using Lemma 1.20, one easily shows by induction that, for all $x \in H_\alpha$ and $l \in \mathbb{N}$,

$$(1.20) \quad (S_{\alpha^{-1}}S_\alpha)^{2l}(x) = g_\alpha^l(\nu^l \rightharpoonup x \leftarrow \nu^{-l})g_\alpha^{-l}.$$

Recall that the order of a grouplike element of a finite-dimensional Hopf algebra A is finite and divides $\dim A$ (see [33, THEOREM 2.2]). Therefore g_1 has a finite order which divides $\dim H_1$ and ν has a finite order which divides $\dim H_1^* = \dim H_1$. Now, since $\alpha^d = 1$ and $(g_\beta^{\dim H_1})_{\beta \in \pi} \in G(H)$,

$$g_\alpha^{d \dim H_1} = (g_1^{\dim H_1})_{(1, \alpha)} \cdots (g_1^{\dim H_1})_{(d, \alpha)} = 1_{1(1, \alpha)} \cdots 1_{1(d, \alpha)} = 1_\alpha^d = 1_\alpha.$$

Then, for all $x \in H_\alpha$, by (1.20),

$$\begin{aligned} (S_{\alpha^{-1}}S_\alpha)^{2d \dim H_1}(x) &= g_\alpha^{d \dim H_1} (v^{d \dim H_1} \rightharpoonup x \leftarrow v^{-d \dim H_1}) g_\alpha^{-d \dim H_1} \\ &= 1_\alpha(\varepsilon \rightharpoonup x \leftarrow \varepsilon)1_\alpha = x. \end{aligned}$$

Hence $(S_{\alpha^{-1}}S_\alpha)^{2d \dim H_1} = \text{id}_{H_\alpha}$. \square

1.5. Semisimplicity and cosemisimplicity

In this section, we define the semisimplicity and the cosemisimplicity for Hopf π -coalgebras, and we give criteria for a Hopf π -coalgebra to be semisimple (resp. cosemisimple).

1.5.1. Semisimple Hopf π -coalgebras. A Hopf π -coalgebra $H = \{H_\alpha\}_{\alpha \in \pi}$ is said to be *semisimple* if each algebra H_α is semisimple.

Note that, since any infinite-dimensional Hopf algebra (over a field) is never semisimple (see [46, COROLLARY 2.7]), a necessary condition for H to be semisimple is that H_1 is finite-dimensional.

LEMMA 1.21. *Let $H = \{H_\alpha\}_{\alpha \in \pi}$ be a finite type Hopf π -coalgebra. Then H is semisimple if and only if H_1 is semisimple.*

Proof. We have to show that if H_1 is semisimple then H is semisimple. Suppose that H_1 is semisimple and fix $\alpha \in \pi$. Since H_α is a finite-dimensional algebra, it suffices to show that all left H_α -modules are completely reducible. Thus let M be a left H_α -module and N be a submodule of M . Since H_1 is a finite-dimensional semisimple Hopf algebra, there exists a left integral Λ for H_1 such that $\varepsilon(\Lambda) = 1$ (cf [45, THEOREM 5.1.8]). Let $p : M \rightarrow N$ be any \mathbb{k} -linear projection which is the identity on N . Let $P : M \rightarrow N$ be the \mathbb{k} -linear map defined, for any $m \in M$, by

$$P(m) = \Lambda_{(1,\alpha)} \cdot p(S_{\alpha^{-1}}(\Lambda_{(2,\alpha^{-1})}) \cdot m),$$

where \cdot denotes the action of H_α on M . The map P is the identity on N since, for any $n \in N$,

$$\begin{aligned} P(n) &= \Lambda_{(1,\alpha)} \cdot p(S_{\alpha^{-1}}(\Lambda_{(2,\alpha^{-1})}) \cdot n) = \Lambda_{(1,\alpha)} \cdot (S_{\alpha^{-1}}(\Lambda_{(2,\alpha^{-1})}) \cdot n) \\ &= (\Lambda_{(1,\alpha)} S_{\alpha^{-1}}(\Lambda_{(2,\alpha^{-1})})) \cdot n = \varepsilon(\Lambda)1_\alpha \cdot n = n. \end{aligned}$$

Let $h \in H_\alpha$. Using (1.2) and the fact that Λ is a left integral for H_1 , we have

$$\begin{aligned} \Lambda_{(1,\alpha)} \otimes \Lambda_{(2,\alpha^{-1})} \otimes h &= \Delta_{\alpha,\alpha^{-1}}(\varepsilon(h_{(1,1)})\Lambda) \otimes h_{(2,\alpha)} \\ &= \Delta_{\alpha,\alpha^{-1}}(h_{(1,1)}\Lambda) \otimes h_{(2,\alpha)} \\ &= h_{(1,\alpha)}\Lambda_{(1,\alpha)} \otimes h_{(2,\alpha^{-1})}\Lambda_{(2,\alpha^{-1})} \otimes h_{(3,\alpha)}, \end{aligned}$$

and so

$$\begin{aligned} \Lambda_{(1,\alpha)} \otimes S_{\alpha^{-1}}(\Lambda_{(2,\alpha^{-1})})h &= h_{(1,\alpha)}\Lambda_{(1,\alpha)} \otimes S_{\alpha^{-1}}(h_{(2,\alpha^{-1})}\Lambda_{(2,\alpha^{-1})})h_{(3,\alpha)} \\ &= h_{(1,\alpha)}\Lambda_{(1,\alpha)} \otimes S_{\alpha^{-1}}(\Lambda_{(2,\alpha^{-1})})S_{\alpha^{-1}}(h_{(2,\alpha^{-1})})h_{(3,\alpha)} \quad \text{by Lemma 1.1(c)} \\ &= h_{(1,\alpha)}\varepsilon(h_{(2,1)})\Lambda_{(1,\alpha)} \otimes S_{\alpha^{-1}}(\Lambda_{(2,\alpha^{-1})})1_\alpha \quad \text{by (1.5)} \\ &= h\Lambda_{(1,\alpha)} \otimes S_{\alpha^{-1}}(\Lambda_{(2,\alpha^{-1})}) \quad \text{by (1.2)}. \end{aligned}$$

Therefore, for all $h \in H_\alpha$ and $m \in M$,

$$P(h \cdot m) = \Lambda_{(1,\alpha)} \cdot p(S_{\alpha^{-1}}(\Lambda_{(2,\alpha^{-1})})h \cdot m) = h\Lambda_{(1,\alpha)} \cdot p(S_{\alpha^{-1}}(\Lambda_{(2,\alpha^{-1})}) \cdot m) = h \cdot P(m).$$

Hence P is H_α -linear and $\ker P$ is a H_α -supplement of N in M . \square

1.5.2. Cosemisimple π -comodules and π -coalgebras. Let C be a π -coalgebra and M be a right π -comodule over C . If $\{N^i = \{N_\alpha^i\}_{\alpha \in \pi}\}_{i \in I}$ is a family of π -subcomodules of M , we define their *sum* by $\{\sum_{i \in I} N_\alpha^i\}_{\alpha \in \pi}$. It is easy to see that it is a π -subcomodule of M . We denote it by $\sum_{i \in I} N^i$. This sum is said to be *direct* provided $\sum_{i \in I} N_\alpha^i$ is a direct sum for all $\alpha \in \pi$. In this case $\sum_{i \in I} N^i$ will be denoted by $\oplus_{i \in I} N^i$.

A right π -comodule $M = \{M_\alpha\}_{\alpha \in \pi}$ is said to be *simple* if it is *non-zero* (i.e., $M_\alpha \neq 0$ for some $\alpha \in \pi$) and if it has no π -subcomodules other than $0 = \{0\}_{\alpha \in \pi}$ and itself.

LEMMA 1.22. *Let M be a right π -comodule over a π -coalgebra C . The following conditions are equivalent:*

- (a) M is a sum of a family of simple π -subcomodules;
- (b) M is a direct sum of a family of simple π -subcomodules;
- (c) Every π -subcomodule N of M is a direct summand, i.e., there exists a π -subcomodule N' of M such that $M = N \oplus N'$.

Proof. Let us show that Condition (a) implies Condition (b). Suppose $M = \sum_{i \in I} M^i$ is a sum of simple π -submodules. Let J be a maximal subset of I such that $\sum_{j \in J} M^j$ is direct. Let us show that this sum is in fact equal to M . It suffices to prove that each M^i ($i \in I$) is contained in this sum. The intersection of our sum with M^i is a π -subcomodule of M^i , thus equal to 0 or M^i . If it is equal to 0, then J is not maximal since we can adjoin i to it. Hence M^i is contained in the sum.

To show that Condition (b) implies Condition (c), suppose $M = \oplus_{i \in I} M^i$ and let N be a π -subcomodule of M . Let J be a maximal subset of I such that the sum $N + \oplus_{j \in J} M^j$ is direct. The same reasoning as before shows this sum is equal to M .

Let us show that Condition (c) implies Condition (a). Let N be the π -subcomodule of M defined as the sum of all simple π -subcomodules of M . Suppose that $M \neq N$. Then $M = N \oplus F$ where F is a non-zero π -subcomodule of M . Let us show that there exists a simple π -subcomodule of F , contradicting the definition of N . By Theorem 1.4(a), $\overline{F} = \oplus_{\alpha \in \pi} \overline{F}_\alpha$ (where $\overline{F}_\alpha = F_{\alpha^{-1}}$) is a rational π -graded left C^* -module, which is non-zero. Let $v \in \overline{F}$, $v \neq 0$. The kernel of the morphism of π -graded left C^* -modules $C^* \rightarrow C^*v$ is a π -graded left ideal $J \neq C^*$. Therefore J is contained in a maximal π -graded left ideal $I \neq C^*$ (by Zorn's lemma). Then I/J is a maximal π -graded left C^* -submodule of C^*/J (not equal to C^*/J), and hence Iv is a maximal π -graded C^* -submodule of C^*v , not equal to C^*v (corresponding to I/J under the π -graded isomorphism $C^*/J \rightarrow C^*v$). Moreover, by Theorem 1.4(b), it is rational since it is a submodule of the rational module \overline{F} . So we can consider the π -subcomodule \overline{Iv} of M (see Lemma 1.6). Write then $M = \overline{Iv} \oplus L$ where L is π -subcomodule of M . Therefore $\overline{M} = Iv \oplus \overline{L}$ and so $C^*v = Iv \oplus (\overline{L} \cap C^*v)$. Now, since Iv is a maximal π -graded C^* -submodule of C^*v (not equal to C^*v), we have that $\overline{L} \cap C^*v$ is a non-zero π -graded C^* -submodule of \overline{F} which does not contain any π -graded submodule other than 0 and itself. Moreover, by Theorem 1.4(b), $\overline{L} \cap C^*v$ is rational since it is a π -graded C^* -submodule of the rational π -graded C^* -module \overline{F} . Finally $\overline{L} \cap C^*v$ is a simple π -subcomodule of F . \square

A right π -comodule satisfying the equivalent conditions of Lemma 1.22 is said to be *cosemisimple*. A π -coalgebra is called *cosemisimple* if it is cosemisimple as a right π -comodule over itself (with comultiplication as structure maps).

When $\pi = 1$, one recovers the usual notions of cosemisimple comodules and coalgebras.

When π is finite, a π -coalgebra $C = \{C_\alpha\}_{\alpha \in \pi}$ is cosemisimple if and only if the π -graded coalgebra $\tilde{C} = \oplus_{\alpha \in \pi} C_\alpha$ (defined as in §1.1.3.5) is *graded-cosemisimple* (i.e., is a direct sum of simple π -graded right comodules).

LEMMA 1.23. *Every π -subcomodule or quotient of a cosemisimple right π -comodule is cosemisimple.*

Proof. Let N be a π -subcomodule of a cosemisimple right π -comodule M . Let F be the sum of all simple π -subcomodules of N and write $M = F \oplus F'$. Therefore $N = F \oplus (F' \cap N)$. If $F' \cap N \neq 0$, it contains a simple π -subcomodule (see the proof of Lemma 1.22). Thus $F' \cap N = 0$ and $N = F$, which is cosemisimple. Now write $M = N \oplus N'$. Since N' is a sum of simple π -subcomodules (it is a π -subcomodule of M and thus cosemisimple) and the canonical projection $M \rightarrow M/N$ induces a π -comodule isomorphism between N' onto M/N , we obtain that M/N is cosemisimple. \square

1.5.3. Cosemisimple Hopf π -coalgebras. A Hopf π -coalgebra $H = \{H_\alpha\}_{\alpha \in \pi}$ is said to be *cosemisimple* if it is cosemisimple as a π -coalgebra. A right π -comodule $M = \{M_\alpha\}_{\alpha \in \pi}$ over H is said to be *reduced* if, for all $\alpha \in \pi$, $M_\alpha = 0$ whenever $H_\alpha = 0$.

The next theorem is the Hopf π -coalgebra version of the dual Maschke Theorem (see [45, §14.0.3]).

THEOREM 1.24. *Let $H = \{H_\alpha\}_{\alpha \in \pi}$ be a Hopf π -coalgebra. The following conditions are equivalent:*

- (a) *Every reduced right π -comodule over H is cosemisimple;*
- (b) *H is cosemisimple;*
- (c) *There exists a right π -integral $\lambda = (\lambda_\alpha)_{\alpha \in \pi}$ for H such that $\lambda_\alpha(1_\alpha) = 1$ for some $\alpha \in \pi$;*
- (d) *There exists a right π -integral $\lambda = (\lambda_\alpha)_{\alpha \in \pi}$ for H such that $\lambda_\alpha(1_\alpha) = 1$ for all $\alpha \in \pi$ with $H_\alpha \neq 0$.*

Proof. Condition (a) implies trivially Condition (b). Moreover Condition (c) is equivalent to Condition (d). Indeed Condition (d) implies Condition (c) since $H_1 \neq 0$ (by Corollary 1.2). Conversely, suppose that $\beta \in \pi$ is such that $\lambda_\beta(1_\beta) = 1$. Let $\alpha \in \pi$ such that $H_\alpha \neq 0$. Then $\lambda_\alpha(1_\alpha) 1_{\beta^{-1}\alpha} = (\lambda_\beta \otimes \text{id}_{H_{\beta^{-1}\alpha}})\Delta_{\beta, \beta^{-1}\alpha}(1_\alpha) = \lambda_\beta(1_\beta) 1_{\beta^{-1}\alpha} = 1_{\beta^{-1}\alpha}$. Now $1_{\beta^{-1}\alpha} \neq 0$ by Corollary 1.2. Hence $\lambda_\alpha(1_\alpha) = 1$.

Let us show that Condition (b) implies Condition (d). Consider H as a right π -comodule over itself (with comultiplication as structure maps). For any $\alpha \in \pi$, set $N_\alpha = \mathbb{k}1_\alpha$. Since the comultiplication is unitary, $N = \{N_\alpha\}_{\alpha \in \pi}$ is a π -subcomodule of H . Therefore N is a direct summand of H (since H is cosemisimple). In particular there exists a π -comodule morphism $p = \{p_\alpha\}_{\alpha \in \pi} : H \rightarrow N$ such that $p_\alpha|_{N_\alpha} = \text{id}_{N_\alpha}$ for all $\alpha \in \pi$. For any $\alpha \in \pi$, since $N_\alpha = \mathbb{k}1_\alpha$, there exists a (unique) \mathbb{k} -form $\lambda_\alpha \in H_\alpha^*$ such that $p_\alpha(h) = \lambda_\alpha(h) 1_\alpha$ for all $h \in H_\alpha$. Let us verify that $\lambda = (\lambda_\alpha)_{\alpha \in \pi}$ is a right π -integral for H . Let $\alpha, \beta \in \pi$. Since p is a π -comodule morphism, we have that

$$(1.21) \quad \lambda_{\alpha\beta} 1_\alpha \otimes 1_\beta = \Delta_{\alpha, \beta} p_{\alpha\beta} = (p_\alpha \otimes \text{id}_{H_\beta})\Delta_{\alpha, \beta} = (\lambda_\alpha 1_\alpha \otimes \text{id}_{H_\beta})\Delta_{\alpha, \beta}.$$

If $H_\alpha = 0$, then either $H_\beta = 0$ or $H_{\alpha\beta} = 0$ (by Corollary 1.2) and so $\lambda_{\alpha\beta} 1_\beta = 0 = (\lambda_\alpha \otimes \text{id}_{H_\beta})\Delta_{\alpha, \beta}$. If $H_\alpha \neq 0$, then there exists $f \in H_\alpha^*$ such that $f(1_\alpha) = 1$ and so, by applying $(f \otimes \text{id}_{H_\beta})$ to both sides of (1.21), we get that $\lambda_{\alpha\beta} 1_\beta = (\lambda_\alpha \otimes \text{id}_{H_\beta})\Delta_{\alpha, \beta}$. Therefore λ is a right π -integral for H . Finally, let $\alpha \in \pi$ such that $H_\alpha \neq 0$. Then $\lambda_\alpha(1_\alpha) 1_\alpha = p_\alpha(1_\alpha) = 1_\alpha$ (since $1_\alpha \in N_\alpha$) and so $\lambda_\alpha(1_\alpha) = 1$ (since $1_\alpha \neq 0$).

To show that Condition (d) implies Condition (a), let $M = \{M_\alpha\}_{\alpha \in \pi}$ be a reduced right π -comodule over H with structure maps by $\rho = \{\rho_{\alpha, \beta}\}_{\alpha, \beta \in \pi}$ and $N = \{N_\alpha\}_{\alpha \in \pi}$ be a π -subcomodule of M . By Lemma 1.22, we have to show that N is a direct summand of M . Define $\delta_\alpha : H_{\alpha^{-1}} \otimes H_\alpha \rightarrow \mathbb{k}$ by $\delta_\alpha(x \otimes y) = \lambda_\alpha(S_{\alpha^{-1}}(x)y)$ for all $\alpha \in \pi$. We first prove that, for any $\alpha, \beta, \gamma \in \pi$,

$$(1.22) \quad (\text{id}_{H_\beta} \otimes \delta_{\alpha\beta})(\Delta_{\beta, (\alpha\beta)^{-1}} \otimes \text{id}_{H_{\alpha\beta}}) = (\delta_\alpha \otimes \text{id}_{H_\beta})(\text{id}_{H_{\alpha^{-1}}} \otimes \Delta_{\alpha, \beta}).$$

Indeed, for any $x \in H_{\alpha^{-1}}$ and $y \in H_{\alpha\beta}$,

$$\begin{aligned} & (\text{id}_{H_\beta} \otimes \delta_{\alpha\beta})(\Delta_{\beta, (\alpha\beta)^{-1}} \otimes \text{id}_{H_{\alpha\beta}})(x \otimes y) \\ &= x_{(1, \beta)} \lambda_{\alpha\beta}(S_{(\alpha\beta)^{-1}}(x_{(2, (\alpha\beta)^{-1})})y) \end{aligned}$$

$$\begin{aligned}
&= x_{(1,\beta)}(\lambda_\alpha \otimes \text{id}_{H_\beta})\Delta_{\alpha,\beta}(S_{(\alpha\beta)^{-1}}(x_{(2,(\alpha\beta)^{-1})})y) \quad \text{by (1.12)} \\
&= x_{(1,\beta)}S_{\beta^{-1}}(x_{(2,\beta^{-1})})y_{(2,\beta)}\lambda_\alpha(S_{\alpha^{-1}}(x_{(3,\alpha^{-1})})y_{(1,\alpha)}) \quad \text{by Lemma 1.1(c)} \\
&= y_{(2,\beta)}\lambda_\alpha(S_{\alpha^{-1}}(\varepsilon(x_{(1,1)})x_{(2,\alpha^{-1})})y_{(1,\alpha)}) \quad \text{by (1.5)} \\
&= \lambda_\alpha(S_{\alpha^{-1}}(x)y_{(1,\alpha)})y_{(2,\beta)} \quad \text{by (1.2)} \\
&= (\delta_\alpha \otimes \text{id}_{H_\beta})(\text{id}_{H_{\alpha^{-1}}} \otimes \Delta_{\alpha,\beta})(x \otimes y).
\end{aligned}$$

Let $q : M_1 \rightarrow N_1$ be any \mathbb{k} -linear projection which is the identity on N_1 . Define, for all $\alpha \in \pi$,

$$p_\alpha = (\text{id}_{N_\alpha} \otimes \delta_\alpha)(\rho_{\alpha,\alpha^{-1}} \circ q \otimes \text{id}_{H_\alpha})\rho_{1,\alpha} : M_\alpha \rightarrow N_\alpha.$$

For any $\alpha, \beta \in \pi$, using (1.6) and (1.22), we have

$$\begin{aligned}
\rho_{\alpha,\beta}p_{\alpha\beta} &= \rho_{\alpha,\beta}(\text{id}_{N_{\alpha\beta}} \otimes \delta_{\alpha\beta})(\rho_{\alpha\beta,(\alpha\beta)^{-1}} \circ q \otimes \text{id}_{H_{\alpha\beta}})\rho_{1,\alpha\beta} \\
&= (\text{id}_{N_\alpha} \otimes \text{id}_{H_\beta} \otimes \delta_{\alpha\beta})(\rho_{\alpha,\beta} \otimes \text{id}_{H_{(\alpha\beta)^{-1}}})\rho_{\alpha\beta,(\alpha\beta)^{-1}} \circ q \otimes \text{id}_{H_{\alpha\beta}}\rho_{1,\alpha\beta} \\
&= (\text{id}_{N_\alpha} \otimes \text{id}_{H_\beta} \otimes \delta_{\alpha\beta})(\text{id}_{N_\alpha} \otimes \Delta_{\beta,(\alpha\beta)^{-1}})\rho_{\alpha,\alpha^{-1}} \circ q \otimes \text{id}_{H_{\alpha\beta}}\rho_{1,\alpha\beta} \\
&= (\text{id}_{N_\alpha} \otimes (\text{id}_{H_\beta} \otimes \delta_{\alpha\beta})(\Delta_{\beta,(\alpha\beta)^{-1}} \otimes \text{id}_{H_{\alpha\beta}}))(\rho_{\alpha,\alpha^{-1}} \circ q \otimes \text{id}_{H_{\alpha\beta}})\rho_{1,\alpha\beta} \\
&= (\text{id}_{N_\alpha} \otimes (\delta_\alpha \otimes \text{id}_{H_\beta})(\text{id}_{H_{\alpha^{-1}}} \otimes \Delta_{\alpha,\beta}))(\rho_{\alpha,\alpha^{-1}} \circ q \otimes \text{id}_{H_{\alpha\beta}})\rho_{1,\alpha\beta} \\
&= (\text{id}_{N_\alpha} \otimes \delta_\alpha \otimes \text{id}_{H_\beta})(\rho_{\alpha,\alpha^{-1}} \circ q \otimes \text{id}_{H_\alpha} \otimes \text{id}_{H_\beta})(\text{id}_{M_1} \otimes \Delta_{\alpha,\beta})\rho_{1,\alpha\beta} \\
&= (\text{id}_{N_\alpha} \otimes \delta_\alpha \otimes \text{id}_{H_\beta})(\rho_{\alpha,\alpha^{-1}} \circ q \otimes \text{id}_{H_\alpha} \otimes \text{id}_{H_\beta})(\rho_{1,\alpha} \otimes \text{id}_{H_\beta})\rho_{\alpha,\beta} \\
&= (p_\alpha \otimes \text{id}_{H_\beta})\rho_{\alpha,\beta}.
\end{aligned}$$

Thus $p = \{p_\alpha\}_{\alpha \in \pi}$ is a π -comodule morphism between M and N . Let $\alpha \in \pi$ and $n \in N_\alpha$. If $H_\alpha = 0$, then $N_\alpha = 0$ (since M and thus N is reduced) and so $p_\alpha(n) = 0 = n$. If $H_\alpha \neq 0$, then

$$\begin{aligned}
p_\alpha(n) &= n_{(0,\alpha)}\lambda_\alpha(S_{\alpha^{-1}}(n_{(1,\alpha^{-1})})n_{(2,\alpha)}) \quad \text{since } q|_{N_1} = \text{id}_{N_1} \\
&= n_{(0,\alpha)}\varepsilon(n_{(1,1)})\lambda_\alpha(1_\alpha) \quad \text{by (1.5)} \\
&= n \quad \text{by (1.7) and since } \lambda_\alpha(1_\alpha) = 1.
\end{aligned}$$

Therefore q is a π -comodule projection of M onto N and consequently N is a direct summand of M (namely $M = N \oplus \ker q$). This finishes the proof of the theorem. \square

COROLLARY 1.25. *Let $H = \{H_\alpha\}_{\alpha \in \pi}$ be a Hopf π -coalgebra. Then*

- (a) *If H is cosemisimple, then the Hopf algebra H_1 is cosemisimple;*
- (b) *If H is of finite type, then H is cosemisimple if and only if H_1 is cosemisimple.*

Proof. To show Part (a), suppose that H is cosemisimple. By Theorem 1.24 and Corollary 1.2, there exists a right π -integral $\lambda = (\lambda_\alpha)_{\alpha \in \pi}$ for H such that $\lambda_1(1_1) = 1$. Since λ_1 is a right integral for H_1^* such that $\lambda_1(1_1) \neq 0$, H_1 is cosemisimple (by [45, THEOREM 14.0.3]). Let us show Part (b). Suppose that H is of finite type and H_1 is cosemisimple. By [45, THEOREM 14.0.3], there exists a right integral ϕ for H_1^* such that $\phi(1_1) = 1$. By Theorem 1.13, there exists a non-zero right π -integral $\lambda = (\lambda_\alpha)_{\alpha \in \pi}$ for H . In particular, λ_1 is a non-zero right integral for H_1^* . Therefore, since H_1 is finite-dimensional, there exists $k \in \mathbb{k}$ such that $\phi = k\lambda_1$ (by [45, THEOREM 5.1.6]). Thus $(k\lambda_\alpha)_{\alpha \in \pi}$ is a right π -integral for H such that $k\lambda_1(1_1) = 1$. Hence H is cosemisimple by Theorem 1.24. \square

COROLLARY 1.26. *Let $H = \{H_\alpha\}_{\alpha \in \pi}$ be a finite type Hopf π -coalgebra over a field \mathbb{k} of characteristic 0. Then H is semisimple if and only if it is cosemisimple.*

Proof. By Lemma 1.21, H is semisimple if and only if H_1 is semisimple, and by Corollary 1.25(b), H is cosemisimple if and only if H_1 is cosemisimple. It is then easy to conclude using the fact that, in characteristic 0, a finite-dimensional Hopf algebra is semisimple if and only if it is cosemisimple (see [23, THEOREM 3.3]). \square

COROLLARY 1.27. *Let $H = \{H_\alpha\}_{\alpha \in \pi}$ be a finite type cosemisimple Hopf π -coalgebra. If $g = (g_\alpha)_{\alpha \in \pi}$ is the distinguished π -grouplike element of H , then $g = 1$ in $G(H)$, i.e., $g_\alpha = 1_\alpha$ for all $\alpha \in \pi$. Consequently, the spaces of left and right π -integrals for H coincide.*

Proof. Let $\alpha \in \pi$. If $H_\alpha = 0$, then $g_\alpha = 0 = 1_\alpha$. Suppose that $H_\alpha \neq 0$. By Theorem 1.24, there exists a right π -integral $\lambda = (\lambda_\gamma)_{\gamma \in \pi}$ for H such that $\lambda_\alpha(1_\alpha) = 1$ and $\lambda_1(1_1) = 1$. Then $g_\alpha = \lambda_\alpha(1_\alpha) g_\alpha = (\text{id}_{H_\alpha} \otimes \lambda_1) \Delta_{\alpha,1}(1_\alpha) = \lambda_1(1_1) 1_\alpha = 1_\alpha$. Moreover, by Theorem 1.13 and Lemma 1.15, the spaces of left and right π -integrals for H coincide. \square

1.6. Involutory Hopf π -coalgebras

In this section we give some results concerning involutory Hopf π -coalgebras which are used for topological purposes in Chapter 5. A Hopf π -coalgebra $H = \{H_\alpha\}_{\alpha \in \pi}$ is said to be *involutory* if the antipode $S = \{S_\alpha\}_{\alpha \in \pi}$ is such that $S_{\alpha^{-1}} S_\alpha = \text{id}_{H_\alpha}$ for all $\alpha \in \pi$.

If A is an algebra and $a \in A$, then $r(a) \in \text{End}(A)$ will denote the right multiplication by a defined by $r(a)(x) = xa$. Moreover, Tr will denote the usual trace of \mathbb{k} -linear endomorphisms of a \mathbb{k} -space.

LEMMA 1.28. *Let $H = \{H_\alpha\}_{\alpha \in \pi}$ be a finite dimensional Hopf π -coalgebra with antipode $S = \{S_\alpha\}_{\alpha \in \pi}$. Let $\lambda = (\lambda_\alpha)_{\alpha \in \pi}$ be a right π -integral for H and Λ be a left integral for H_1 such that $\lambda_1(\Lambda) = 1$. Let $\alpha \in \pi$. Then*

- (a) $\text{Tr}(f) = \lambda_\alpha(S_{\alpha^{-1}}(\Lambda_{(2,\alpha^{-1})})f(\Lambda_{(1,\alpha)}))$ for all $f \in \text{End}H_\alpha$;
- (b) $\text{Tr}(r(a) \circ S_{\alpha^{-1}} S_\alpha) = \epsilon(\Lambda) \lambda_\alpha(a)$ for all $a \in H_\alpha$;
- (c) If $H_\alpha \neq 0$, then $\text{Tr}(S_{\alpha^{-1}} S_\alpha) \neq 0$ if and only if H is semisimple and cosemisimple;
- (d) If $H_\alpha \neq 0$, then $\text{Tr}(S_{\alpha^{-1}} S_\alpha) = \text{Tr}(S_1^2)$.

Proof. To show Part (a), identify $H_\alpha^* \otimes H_\alpha$ and $\text{End}(H_\alpha)$ by $(p \otimes a)(x) = p(x)a$ for all $p \in H_\alpha^*$ and $a, x \in H_\alpha$. Under this identification, $\text{Tr}(p \otimes a) = p(a)$. Let $f \in \text{End}(H_\alpha)$. We may assume that $f = p \otimes a$ for some $p \in H_\alpha^*$ and $a \in H_\alpha$. By Corollary 1.14(b), since λ is non-zero, there exists $b \in H_\alpha$ such that $p = \lambda_\alpha(b \cdots)$. Now,

$$b = \lambda_\alpha(b \Lambda_{(1,\alpha)}) S_{\alpha^{-1}}(\Lambda_{(2,\alpha^{-1})}) = p(\Lambda_{(1,\alpha)}) S_{\alpha^{-1}}(\Lambda_{(2,\alpha^{-1})}) \quad \text{by Lemma 1.17(b).}$$

Therefore

$$\begin{aligned} \text{Tr}(f) &= p(a) = \lambda_\alpha(ba) \\ &= \lambda_\alpha(S_{\alpha^{-1}}(\Lambda_{(2,\alpha^{-1})})p(\Lambda_{(1,\alpha)})a) \\ &= \lambda_\alpha(S_{\alpha^{-1}}(\Lambda_{(2,\alpha^{-1})})f(\Lambda_{(1,\alpha)})) \end{aligned}$$

Let us show Part (b). Let $a \in H_\alpha$. Then

$$\begin{aligned} \text{Tr}(r(a) \circ S_{\alpha^{-1}} S_\alpha) &= \lambda_\alpha(S_{\alpha^{-1}}(\Lambda_{(2,\alpha^{-1})}) S_{\alpha^{-1}} S_\alpha(\Lambda_{(1,\alpha)})a) \quad \text{by Part (a)} \\ &= \lambda_\alpha(S_{\alpha^{-1}}(S_\alpha(\Lambda_{(1,\alpha)}) \Lambda_{(2,\alpha^{-1})})a) \\ &= \lambda_\alpha(S_{\alpha^{-1}}(\epsilon(\Lambda) 1_{\alpha^{-1}})a) \\ &= \epsilon(\Lambda) \lambda_\alpha(a) \end{aligned}$$

To show Part (c), suppose $H_\alpha \neq 0$. Since $\text{Tr}(S_{\alpha^{-1}} S_\alpha) = \epsilon(\Lambda) \lambda_\alpha(1_\alpha)$ (by Part (b)), one easily concludes using the facts that H is semisimple if and only if $\epsilon(\Lambda) \neq 0$ (by Lemma 1.21 and [45, THEOREM 5.1.8]) and H is cosemisimple if and only if $\lambda_\alpha(1_\alpha) \neq 0$ (by Theorem 1.24 since $H_\alpha \neq 0$).

Let us show Part (d). By using (1.12), we have $\lambda_1(1_1) 1_\alpha = (\lambda_1 \otimes \text{id}_{H_\alpha}) \Delta_{1,\alpha}(1_\alpha) = \lambda_\alpha(1_\alpha) 1_\alpha$, and so $\lambda_\alpha(1_\alpha) = \lambda_1(1_1)$ since $1_\alpha \neq 0$ (because $H_\alpha \neq 0$). Therefore, by applying Part (b) twice, we obtain that $\text{Tr}(S_{\alpha^{-1}} S_\alpha) = \epsilon(\Lambda) \lambda_\alpha(1_\alpha) = \epsilon(\Lambda) \lambda_1(1_1) = \text{Tr}(S_1^2)$. \square

COROLLARY 1.29. *Let $H = \{H_\alpha\}_{\alpha \in \pi}$ be a finite dimensional involutory Hopf π -coalgebra over a field of characteristic p . Let $\alpha \in \pi$ with $H_\alpha \neq 0$. If $p = 0$ is of characteristic 0 or $p > |\dim H_\alpha - \dim H_1|$, then $\dim H_\alpha = \dim H_1$.*

Proof. By Lemma 1.28(d), we have $\text{Tr}(S_{\alpha^{-1}}S_\alpha) = \text{Tr}(S_1^2)$, that is $(\dim H_\alpha)1_{\mathbb{k}} = (\dim H_1)1_{\mathbb{k}}$ (since H is involutory). One easily concludes by using the hypothesis on the characteristic of the field \mathbb{k} . \square

COROLLARY 1.30. *Let $H = \{H_\alpha\}_{\alpha \in \pi}$ be a finite dimensional involutory Hopf π -coalgebra. Suppose that $\dim H_1 \neq 0$ in the ground field \mathbb{k} of H . Then H is semisimple and cosemisimple.*

Proof. This follows from Lemma 1.28(c), since $\text{Tr}(S_1^2) = \text{Tr}(\text{id}_{H_1}) = \dim H_1 \neq 0$. \square

CHAPTER 2

Quasitriangular Hopf group-coalgebras

Quasitriangular Hopf group-coalgebras are the algebraic data used in Chapter 4 to construct Hennings-like invariants of flat bundles over link complements and over 3-manifolds.

Following [48], a crossing for a Hopf π -coalgebra $H = \{H_\alpha\}_{\alpha \in \pi}$ is a family of algebra isomorphisms $\varphi = \{\varphi_\beta : H_\alpha \rightarrow H_{\beta\alpha\beta^{-1}}\}_{\alpha, \beta \in \pi}$ which preserves the comultiplication and the counit, and yields an action of π in the sense that $\varphi_\beta \varphi_{\beta'} = \varphi_{\beta\beta'}$. A crossed Hopf π -coalgebra $H = \{H_\alpha\}_{\alpha \in \pi}$ is quasitriangular (resp. ribbon) when it is endowed with an R -matrix $R = \{R_{\alpha, \beta} \in H_\alpha \otimes H_\beta\}_{\alpha, \beta \in \pi}$ (resp. an R -matrix and a twist $\theta = \{\theta_\alpha \in H_\alpha\}_{\alpha \in \pi}$) verifying some axioms which generalize the classical ones given in [7] (resp. [40]).

The notion of a trace for a Hopf algebra can be extended to the setting of Hopf π -coalgebras: by a π -trace for crossed Hopf π -coalgebra $H = \{H_\alpha\}_{\alpha \in \pi}$, we shall mean a family of \mathbb{k} -forms $\text{tr} = (\text{tr}_\alpha : H_\alpha \rightarrow \mathbb{k})_{\alpha \in \pi}$ which verifies $\text{tr}_\alpha(xy) = \text{tr}_\alpha(yx)$, $\text{tr}_{\alpha^{-1}}(S_\alpha(x)) = \text{tr}_\alpha(x)$, and $\text{tr}_{\beta\alpha\beta^{-1}}(\varphi_\beta(x)) = \text{tr}_\alpha(x)$ for all $\alpha, \beta \in \pi$ and $x, y \in H_\alpha$.

The main result of this chapter is the existence of π -traces for a semisimple (resp. cosemisimple) finite type unimodular ribbon Hopf π -coalgebra. To prove this result, we generalize the main properties of quasitriangular Hopf algebras (see [8, 15, 38]). In particular, we introduce and study the (generalized) Drinfeld elements of a quasitriangular Hopf π -coalgebra H , we compute the distinguished π -grouplike element of H by using the R -matrix, and we show that the twist of a ribbon Hopf π -coalgebra leads to a π -grouplike element which implements the square of the antipode by conjugation.

When π is a finite group, we can reformulate the main definitions and results concerning Hopf π -coalgebras into the language of central prolongations of the Hopf algebra of functions on π .

This chapter is organized as follows. In Section 2.1, we study crossed, quasitriangular, and ribbon Hopf π -coalgebras. In Section 2.2, we construct π -traces. In Section 2.3, we give an abstract formulation of the main definitions and results in the case π finite. Finally, we give examples of Hopf group-coalgebras in Section 2.4.

2.1. Quasitriangular Hopf π -coalgebras

In this section, we recall the definitions of crossed, quasitriangular, and ribbon Hopf π -coalgebras given by Turaev in [48], and we generalize the main properties of quasitriangular Hopf algebras to the setting of Hopf π -coalgebras.

2.1.1. Crossed Hopf π -coalgebras. Following [48, §11.2], a Hopf π -coalgebra $H = \{H_\alpha\}_{\alpha \in \pi}$ is said to be *crossed* provided it is endowed with a family $\varphi = \{\varphi_\beta : H_\alpha \rightarrow H_{\beta\alpha\beta^{-1}}\}_{\alpha, \beta \in \pi}$ of \mathbb{k} -linear maps (the *crossing*) such that

- (2.1) each $\varphi_\beta : H_\alpha \rightarrow H_{\beta\alpha\beta^{-1}}$ is an algebra isomorphism;
- (2.2) each φ_β preserves the comultiplication, i.e., for all $\alpha, \beta, \gamma \in \pi$,

$$(\varphi_\beta \otimes \varphi_\beta)\Delta_{\alpha, \gamma} = \Delta_{\beta\alpha\beta^{-1}, \beta\gamma\beta^{-1}}\varphi_\beta;$$

- (2.3) each φ_β preserves the counit, i.e., $\varepsilon\varphi_\beta = \varepsilon$;
- (2.4) φ is *multiplicative* in the sense that $\varphi_{\beta\beta'} = \varphi_\beta \varphi_{\beta'}$ for all $\beta, \beta' \in \pi$.

LEMMA 2.1. *Let $H = \{H_\alpha\}_{\alpha \in \pi}$ be a crossed Hopf π -coalgebra with crossing φ . Then*

- (a) $\varphi_{1|H_\alpha} = \text{id}_{H_\alpha}$ for all $\alpha \in \pi$;
- (b) $\varphi_\beta^{-1} = \varphi_{\beta^{-1}}$ for all $\beta \in \pi$;
- (c) φ preserves the antipode, i.e., $\varphi_\beta S_\alpha = S_{\beta\alpha\beta^{-1}}\varphi_\beta$ for all $\alpha, \beta \in \pi$;
- (d) If $\lambda = (\lambda_\alpha)_{\alpha \in \pi}$ is a left (resp. right) π -integral for H and $\beta \in \pi$, then $(\lambda_{\beta\alpha\beta^{-1}}\varphi_\beta)_{\alpha \in \pi}$ is also a left (resp. right) π -integral for H ;
- (e) If $g = (g_\alpha)_{\alpha \in \pi}$ is a π -grouplike element of H and $\beta \in \pi$, then $(\varphi_\beta(g_{\beta^{-1}\alpha\beta}))_{\alpha \in \pi}$ is also a π -grouplike element of H .

Proof. Parts (a), (b), (d) and (e) follow directly from the axioms of a crossing. To show Part (c), let $\alpha, \beta \in \pi$. Using the axioms, it is easy to verify that $\varphi_\beta^{-1} S_{\beta\alpha\beta^{-1}} \varphi_\beta * \text{id}_{H_{\alpha^{-1}}} = \varepsilon 1_{\alpha^{-1}}$ in the convolution algebra $\text{Conv}(H, H_{\alpha^{-1}})$ (see §1.1.2). Thus, since S_α is the inverse of $\text{id}_{H_{\alpha^{-1}}}$ in $\text{Conv}(H, H_{\alpha^{-1}})$, we have that $\varphi_\beta^{-1} S_{\beta\alpha\beta^{-1}} \varphi_\beta = S_\alpha$ and so $S_{\beta\alpha\beta^{-1}} \varphi_\beta = \varphi_\beta S_\alpha$. \square

COROLLARY 2.2. *Let $H = \{H_\alpha\}_{\alpha \in \pi}$ be a finite type crossed Hopf π -coalgebra with crossing φ . Then there exists a unique group homomorphism $\widehat{\varphi} : \pi \rightarrow \mathbb{k}^*$ such that if $\lambda = (\lambda_\alpha)_{\alpha \in \pi}$ is a left or right π -integral for H , then $\lambda_{\beta\alpha\beta^{-1}}\varphi_\beta = \widehat{\varphi}(\beta)\lambda_\alpha$ for all $\alpha, \beta \in \pi$.*

Proof. Let $\lambda = (\lambda_\alpha)_{\alpha \in \pi}$ be a non-zero left π -integral for H . For any $\beta \in \pi$, since $(\lambda_{\beta\alpha\beta^{-1}}\varphi_\beta)_{\alpha \in \pi}$ is a non-zero left π -integral for H (by Lemma 2.1(d) and by the uniqueness (within scalar multiple) of a left π -integral in the finite type case (see Theorem 1.13), there exists a unique $\widehat{\varphi}(\beta) \in \mathbb{k}^*$ such that $\lambda_{\beta\alpha\beta^{-1}}\varphi_\beta = \widehat{\varphi}(\beta)\lambda_\alpha$ for all $\alpha \in \pi$. Using (2.4) and Lemma 2.1, one verifies that $\widehat{\varphi} : \pi \rightarrow \mathbb{k}^*$ is a group homomorphism. Since any left π -integral for H is a scalar multiple of λ , the result holds for any left π -integral. Finally, let $\lambda = (\lambda_\alpha)_{\alpha \in \pi}$ be a right π -integral for H . Since the antipode is bijective (H is of finite type), and using Lemma 2.1(d) and the fact that $(\lambda_{\alpha^{-1}} S_\alpha)_{\alpha \in \pi}$ is a left π -integral for H , we have that, for all $\alpha, \beta \in \pi$, $\lambda_{\beta\alpha\beta^{-1}}\varphi_\beta = \lambda_{\beta\alpha\beta^{-1}} S_{\beta\alpha\beta^{-1}} \varphi_\beta S_{\alpha^{-1}}^{-1} = \widehat{\varphi}(\beta)\lambda_\alpha S_{\alpha^{-1}} S_{\alpha^{-1}}^{-1} = \widehat{\varphi}(\beta)\lambda_\alpha$. \square

LEMMA 2.3. *Let $H = \{H_\alpha\}_{\alpha \in \pi}$ be a finite type crossed Hopf π -coalgebra with crossing φ . Let $\widehat{\varphi}$ be as in Corollary 2.2. Then, for any $\beta \in \pi$,*

- (a) If Λ is a left or right integral for H_1 , then $\varphi_\beta(\Lambda) = \widehat{\varphi}(\beta)\Lambda$;
- (b) If ν is the distinguished grouplike element of H_1^* , then $\nu\varphi_\beta = \nu$;
- (c) If $g = (g_\alpha)_{\alpha \in \pi}$ is the distinguished π -grouplike element of H , then $\varphi_\beta(g_\alpha) = g_{\beta\alpha\beta^{-1}}$ for all $\alpha \in \pi$.

Proof. Let us show Part (a). Let Λ be a left integral for H_1 . We can assume that $\Lambda \neq 0$ (if $\Lambda = 0$, then the result is obvious). By Lemma 2.1 and (2.3), $x\varphi_\beta(\Lambda) = \varphi_\beta(\varphi_{\beta^{-1}}(x)\Lambda) = \varphi_\beta(\varepsilon\varphi_{\beta^{-1}}(x)\Lambda) = \varepsilon(x)\varphi_\beta(\Lambda)$ for any $x \in H_1$. Thus $\varphi_\beta(\Lambda)$ is a left integral for H_1 . Therefore, since H_1 is finite-dimensional and $\Lambda \neq 0$, there exists $k \in \mathbb{k}$ such that $\varphi_\beta(\Lambda) = k\Lambda$. Let $\lambda = (\lambda_\alpha)_{\alpha \in \pi}$ be a non-zero right π -integral for H . We have that $\widehat{\varphi}(\beta)\lambda_1(\Lambda) = \lambda_1(\varphi_\beta(\Lambda)) = \lambda_1(k\Lambda) = k\lambda_1(\Lambda)$. Now $\lambda_1(\Lambda) \neq 0$ (because Λ is a non-zero left integral for H_1 and λ_1 is a non-zero right integral for H_1^*). Hence $k = \widehat{\varphi}(\beta)$ and so $\varphi_\beta(\Lambda) = \widehat{\varphi}(\beta)\Lambda$. It can be shown similarly that the result holds if Λ is a right integral for H_1 .

Let us show Part (b). If Λ is a left integral for H_1 , then, for all $x \in H_1$, $\Lambda x = \varphi_{\beta^{-1}}(\varphi_\beta(\Lambda)\varphi_\beta(x)) = \varphi_{\beta^{-1}}(\nu(\varphi_\beta(x))\varphi_\beta(\Lambda)) = \nu\varphi_\beta(x)\Lambda$ (since $\varphi_\beta(\Lambda)$ is a left integral for H_1). Thus, by the uniqueness of the distinguished grouplike element of the Hopf algebra H_1^* , we have that $\nu\varphi_\beta = \nu$.

To show Part (c), let $\lambda = (\lambda_\alpha)_{\alpha \in \pi}$ be a right π -integral for H . By Lemma 2.1(d), $(\lambda_{\beta^{-1}\alpha\beta}\varphi_{\beta^{-1}})_{\alpha \in \pi}$ is also a right π -integral for H . Then, for any $\alpha, \gamma \in \pi$, using (2.2) and Lemmas 1.15 and 2.1, we have

$$(\text{id}_{H_\alpha} \otimes \lambda_\gamma)\Delta_{\alpha,\gamma} = \varphi_{\beta^{-1}}(\text{id}_{H_{\beta\alpha\beta^{-1}}} \otimes \lambda_\gamma\varphi_{\beta^{-1}})\Delta_{\beta\alpha\beta^{-1},\beta\gamma\beta^{-1}}\varphi_\beta$$

$$\begin{aligned}
&= \varphi_{\beta^{-1}}(\lambda_{\alpha\gamma}\varphi_{\beta^{-1}}\varphi_{\beta}g_{\beta\alpha\beta^{-1}}) \\
&= \lambda_{\alpha\gamma}\varphi_{\beta^{-1}}(g_{\beta\alpha\beta^{-1}}).
\end{aligned}$$

Hence, by the uniqueness of the distinguished π -grouplike element (see Lemma 1.15), we have that $\varphi_{\beta^{-1}}(g_{\beta\alpha\beta^{-1}}) = g_{\alpha}$ and so $\varphi_{\beta}(g_{\alpha}) = g_{\beta\alpha\beta^{-1}}$ for all $\alpha \in \pi$. \square

2.1.1.1. The opposite (resp. coopposite) Hopf π -coalgebra. Let $H = \{H_{\alpha}\}_{\alpha \in \pi}$ be a crossed Hopf π -coalgebra with crossing φ . If the antipode of H is bijective, then the opposite (resp. coopposite) Hopf π -coalgebra to H (see §1.1.3.1 and §1.1.3.2) is crossed with crossing given by $\varphi_{\beta}^{\text{op}}|_{H_{\alpha}^{\text{op}}} = \varphi_{\beta}|_{H_{\alpha}}$ (resp. $\varphi_{\beta}^{\text{cop}}|_{H_{\alpha}^{\text{cop}}} = \varphi_{\beta}|_{H_{\alpha^{-1}}}$) for all $\alpha, \beta \in \pi$.

2.1.1.2. The mirror Hopf π -coalgebra. Let $H = (\{H_{\alpha}\}, \Delta, \varepsilon, S, \varphi)$ be a crossed Hopf π -coalgebra. Following [48, §11.6], its *mirror* \overline{H} is defined by the following procedure: set $\overline{H}_{\alpha} = H_{\alpha^{-1}}$ as an algebra, $\overline{\Delta}_{\alpha,\beta} = (\varphi_{\beta} \otimes \text{id}_{H_{\beta^{-1}}})\Delta_{\beta^{-1}\alpha^{-1}\beta,\beta^{-1}}$, $\overline{\varepsilon} = \varepsilon$, $\overline{S}_{\alpha} = \varphi_{\alpha}S_{\alpha^{-1}}$ and $\overline{\varphi}_{\beta}|_{\overline{H}_{\alpha}} = \varphi_{\beta}|_{H_{\alpha^{-1}}}$. It is also a crossed Hopf π -coalgebra.

2.1.2. Quasitriangular Hopf π -coalgebras. Following [48, §11.3], a *quasitriangular* Hopf π -coalgebra is a crossed Hopf π -coalgebra $H = (\{H_{\alpha}\}, \Delta, \varepsilon, S, \varphi)$ endowed with a family $R = \{R_{\alpha,\beta} \in H_{\alpha} \otimes H_{\beta}\}_{\alpha,\beta \in \pi}$ of invertible elements (the *R-matrix*) such that

(2.5) for any $\alpha, \beta \in \pi$ and $x \in H_{\alpha\beta}$,

$$R_{\alpha,\beta} \cdot \Delta_{\alpha,\beta}(x) = \sigma_{\beta,\alpha}(\varphi_{\alpha^{-1}} \otimes \text{id}_{H_{\alpha}})\Delta_{\alpha\beta\alpha^{-1},\alpha}(x) \cdot R_{\alpha,\beta}$$

where $\sigma_{\beta,\alpha}$ denotes the flip map $\sigma_{H_{\beta},H_{\alpha}} : H_{\beta} \otimes H_{\alpha} \rightarrow H_{\alpha} \otimes H_{\beta}$;

(2.6) for any $\alpha, \beta \in \pi$,

$$\begin{aligned}
(\text{id}_{H_{\alpha}} \otimes \Delta_{\beta,\gamma})(R_{\alpha,\beta\gamma}) &= (R_{\alpha,\gamma})_{1\beta 3} \cdot (R_{\alpha,\beta})_{12\gamma} \\
(\Delta_{\alpha,\beta} \otimes \text{id}_{H_{\gamma}})(R_{\alpha\beta,\gamma}) &= [(\text{id}_{H_{\alpha}} \otimes \varphi_{\beta^{-1}})(R_{\alpha,\beta\gamma\beta^{-1}})]_{1\beta 3} \cdot (R_{\beta,\gamma})_{\alpha 23}
\end{aligned}$$

where, for \mathbb{k} -spaces P, Q and $r = \sum_j p_j \otimes q_j \in P \otimes Q$, we set $r_{12\gamma} = r \otimes 1_{\gamma} \in P \otimes Q \otimes H_{\gamma}$, $r_{\alpha 23} = 1_{\alpha} \otimes r \in H_{\alpha} \otimes P \otimes Q$, and $r_{1\beta 3} = \sum_j p_j \otimes 1_{\beta} \otimes q_j \in P \otimes H_{\beta} \otimes Q$;

(2.7) the family R is invariant under the crossing, i.e., for any $\alpha, \beta, \gamma \in \pi$,

$$(\varphi_{\beta} \otimes \varphi_{\beta})(R_{\alpha,\gamma}) = R_{\beta\alpha\beta^{-1},\beta\gamma\beta^{-1}}.$$

Note that $R_{1,1}$ is a (classical) *R-matrix* for the Hopf algebra H_1 .

When π is abelian and φ is *trivial* (that is, $\varphi_{\beta}|_{H_{\alpha}} = \text{id}_{H_{\alpha}}$ for all $\alpha, \beta \in \pi$), one recovers the definition of a quasitriangular π -colored Hopf algebra given by Ohtsuki in [34].

If π is finite, then an *R-matrix* for H does not necessarily give rise to a (usual) *R-matrix* for the Hopf algebra $\tilde{H} = \bigoplus_{\alpha \in \pi} H_{\alpha}$ since an action of π is involved (see Sect. 2.3.4). However, if the group π is finite abelian and if φ is trivial, then $\tilde{R} = \sum_{\alpha,\beta \in \pi} R_{\alpha,\beta}$ is an *R-matrix* for \tilde{H} .

Notation. In the proofs, when we write a component $R_{\alpha,\beta}$ of an *R-matrix* as $R_{\alpha,\beta} = a_{\alpha} \otimes b_{\beta}$, it is to signify that $R_{\alpha,\beta} = \sum_j a_j \otimes b_j$ for some $a_j \in H_{\alpha}$ and $b_j \in H_{\beta}$, where j runs over a finite set of indices.

We now generalize the main properties of quasitriangular Hopf algebras (see [8, 15]) to the setting of quasitriangular Hopf π -coalgebras.

LEMMA 2.4. *Let $H = (\{H_{\alpha}\}, \Delta, \varepsilon, S, \varphi, R)$ be a quasitriangular Hopf π -coalgebra. Then, for any $\alpha, \beta, \gamma \in \pi$,*

- (a) $(\varepsilon \otimes \text{id}_{H_{\alpha}})(R_{1,\alpha}) = 1_{\alpha} = (\text{id}_{H_{\alpha}} \otimes \varepsilon)(R_{\alpha,1})$;
- (b) $(S_{\alpha^{-1}}\varphi_{\alpha} \otimes \text{id}_{H_{\beta}})(R_{\alpha^{-1},\beta}) = R_{\alpha,\beta}^{-1}$ and $(\text{id}_{H_{\alpha}} \otimes S_{\beta})(R_{\alpha,\beta}^{-1}) = R_{\alpha,\beta^{-1}}$;

$$\begin{aligned}
\text{(c)} \quad & (S_\alpha \otimes S_\beta)(R_{\alpha,\beta}) = (\varphi_\alpha \otimes \text{id}_{H_{\beta^{-1}}})(R_{\alpha^{-1},\beta^{-1}}); \\
\text{(d)} \quad & (R_{\beta,\gamma})_{\alpha 23} \cdot (R_{\alpha,\gamma})_{1\beta 3} \cdot (R_{\alpha,\beta})_{12\gamma} \\
& = (R_{\alpha,\beta})_{12\gamma} \cdot [(\text{id}_{H_\alpha} \otimes \varphi_{\beta^{-1}})(R_{\alpha,\beta\gamma\beta^{-1}})]_{1\beta 3} \cdot (R_{\beta,\gamma})_{\alpha 23}.
\end{aligned}$$

Part (d) of Lemma 2.4, which is the Yang-Baxter equality for $R = \{R_{\alpha,\beta}\}_{\alpha,\beta \in \pi}$, first appeared in [48, §11.3]. We prove it here for completeness sake.

Proof. Let us show Part (a). We have

$$\begin{aligned}
R_{1,\alpha} & = (\varepsilon \otimes \text{id}_{H_1} \otimes \text{id}_{H_\alpha})(\Delta_{1,1} \otimes \text{id}_{H_\alpha})(R_{1,\alpha}) \quad \text{by (1.2)} \\
& = (\varepsilon \otimes \text{id}_{H_1} \otimes \text{id}_{H_\alpha})((\text{id}_{H_1} \otimes \varphi_1)(R_{1,\alpha}))_{11\pi 3} \cdot (R_{1,\alpha})_{1\pi 23} \quad \text{by (2.6)} \\
& = (\varepsilon \otimes \text{id}_{H_1} \otimes \text{id}_{H_\alpha})((R_{1,\alpha})_{11\pi 3} \cdot (R_{1,\alpha})_{1\pi 23}) \quad \text{by Lemma 2.1(a)} \\
& = (\varepsilon \otimes \text{id}_{H_1} \otimes \text{id}_{H_\alpha})((R_{1,\alpha})_{11\pi 3}) \cdot (\varepsilon \otimes \text{id}_{H_1} \otimes \text{id}_{H_\alpha})((R_{1,\alpha})_{1\pi 23}) \quad \text{by (1.4)} \\
& = (1_1 \otimes (\varepsilon \otimes \text{id}_{H_\alpha})(R_{1,\alpha})) \cdot R_{1,\alpha}.
\end{aligned}$$

Thus $1_1 \otimes (\varepsilon \otimes \text{id}_{H_\alpha})(R_{1,\alpha}) = 1_1 \otimes 1_\alpha$ (since $R_{1,\alpha}$ is invertible). By applying $(\varepsilon \otimes \text{id}_{H_\alpha})$ on both sides, we get the first equality of Part (a). The second one can be obtained similarly.

To show the first equality of Part (b), set

$$\mathcal{E} = (m_\alpha \otimes \text{id}_{H_\beta})(S_{\alpha^{-1}} \otimes \text{id}_{H_\alpha} \otimes \text{id}_{H_\beta})(\Delta_{\alpha^{-1},\alpha} \otimes \text{id}_{H_\beta})(R_{1,\beta}).$$

Let us compute \mathcal{E} in two different ways. On one hand,

$$\begin{aligned}
\mathcal{E} & = (m_\alpha \otimes \text{id}_{H_\beta})(S_{\alpha^{-1}} \otimes \text{id}_{H_\alpha} \otimes \text{id}_{H_\beta})((\text{id}_{H_{\alpha^{-1}}} \otimes \varphi_{\alpha^{-1}})(R_{\alpha^{-1},\alpha\beta\alpha^{-1}}))_{1\alpha 3} \cdot (R_{\alpha,\beta})_{\alpha^{-1} 23} \quad \text{by (2.6)} \\
& = (S_{\alpha^{-1}} \otimes \varphi_{\alpha^{-1}})(R_{\alpha^{-1},\alpha\beta\alpha^{-1}}) \cdot R_{\alpha,\beta} \\
& = (S_{\alpha^{-1}} \varphi_\alpha \otimes \text{id}_{H_\beta})(R_{\alpha^{-1},\beta}) \cdot R_{\alpha,\beta} \quad \text{by (2.7)}.
\end{aligned}$$

On the other one,

$$\begin{aligned}
\mathcal{E} & = (\varepsilon 1_\alpha \otimes \text{id}_{H_\beta})(R_{1,\beta}) \quad \text{by (1.5)} \\
& = 1_\alpha \otimes 1_\beta \quad \text{by Part (a)}.
\end{aligned}$$

Comparing these two computations and since $R_{\alpha,\beta}$ is invertible, we get the first equality of Part (b). The second one can be proved similarly by computing the expression $\mathcal{F} = (\text{id}_{H_\alpha} \otimes m_{\beta^{-1}})(\text{id}_{H_\alpha} \otimes \text{id}_{H_{\beta^{-1}}} \otimes S_\beta)(\text{id}_{H_\alpha} \otimes \Delta_{\beta^{-1},\beta})(R_{\alpha,1}^{-1})$.

Part (c) is a direct consequence of Part (b) and Lemma 2.1(a) and (c).

Finally, Part (d) follows from axioms (2.5) and (2.6):

$$\begin{aligned}
& (R_{\beta,\gamma})_{\alpha 23} \cdot (R_{\alpha,\gamma})_{1\beta 3} \cdot (R_{\alpha,\beta})_{12\gamma} \\
& = (R_{\beta,\gamma})_{\alpha 23} \cdot (\text{id}_{H_\alpha} \otimes \Delta_{\beta,\gamma})(R_{\alpha,\beta\gamma}) \\
& = (\text{id}_{H_\alpha} \otimes R_{\beta,\gamma} \cdot \Delta_{\beta,\gamma})(R_{\alpha,\beta\gamma}) \\
& = (\text{id}_{H_\alpha} \otimes \sigma_{\gamma,\beta}(\varphi_{\beta^{-1}} \otimes \text{id}_{H_\beta})\Delta_{\beta\gamma\beta^{-1},\beta} \cdot R_{\beta,\gamma})(R_{\alpha,\beta\gamma}) \\
& = (\text{id}_{H_\alpha} \otimes \sigma_{\gamma,\beta}(\varphi_{\beta^{-1}} \otimes \text{id}_{H_\beta}))((R_{\alpha,\beta})_{1\beta\gamma\beta^{-1} 3} \cdot (R_{\alpha,\beta\gamma\beta^{-1}})_{12\beta}) \cdot (R_{\beta,\gamma})_{\alpha 23} \\
& = (R_{\alpha,\beta})_{12\gamma} \cdot [(\text{id}_{H_\alpha} \otimes \varphi_{\beta^{-1}})(R_{\alpha,\beta\gamma\beta^{-1}})]_{1\beta 3} \cdot (R_{\beta,\gamma})_{\alpha 23}.
\end{aligned}$$

This completes the proof of the lemma. \square

2.1.3. The Drinfeld elements. Let $H = (\{H_\alpha, m_\alpha, 1_\alpha\}, \Delta, \varepsilon, S, \varphi, R)$ be a quasitriangular Hopf π -coalgebra. We define the (*generalized*) *Drinfeld elements* of H , for any $\alpha \in \pi$, by

$$u_\alpha = m_\alpha(S_{\alpha^{-1}}\varphi_\alpha \otimes \text{id}_{H_\alpha})\sigma_{\alpha,\alpha^{-1}}(R_{\alpha,\alpha^{-1}}) \in H_\alpha.$$

Note that u_1 is the Drinfeld element of the quasitriangular Hopf algebra H_1 (see [8]).

LEMMA 2.5. *For any $\alpha, \beta \in \pi$,*

- (a) u_α is invertible and $u_\alpha^{-1} = m_\alpha(\text{id}_{H_\alpha} \otimes S_{\alpha^{-1}}S_\alpha)\sigma_{\alpha,\alpha}(R_{\alpha,\alpha})$;
- (b) $S_{\alpha^{-1}}S_\alpha(\varphi_\alpha(x)) = u_\alpha x u_\alpha^{-1}$ for all $x \in H_\alpha$;
- (c) The antipode of H is bijective;
- (d) $\varphi_\beta(u_\alpha) = u_{\beta\alpha\beta^{-1}}$;
- (e) $S_{\alpha^{-1}}(u_{\alpha^{-1}})u_\alpha = u_\alpha S_{\alpha^{-1}}(u_{\alpha^{-1}})$ and this element, noted c_α , verifies $c_\alpha \varphi_{\alpha^{-1}}(x) = \varphi_\alpha(x)c_\alpha$ for all $x \in H_\alpha$;
- (f) $\Delta_{\alpha,\beta}(u_{\alpha\beta}) = [\sigma_{\beta,\alpha}(\text{id}_{H_\beta} \otimes \varphi_\alpha)(R_{\beta,\alpha}) \cdot R_{\alpha,\beta}]^{-1} \cdot (u_\alpha \otimes u_\beta)$
 $= (u_\alpha \otimes u_\beta) \cdot [\sigma_{\beta,\alpha}(\varphi_{\beta^{-1}} \otimes \text{id}_{H_\alpha})(R_{\beta,\alpha}) \cdot (\varphi_{\alpha^{-1}} \otimes \varphi_{\beta^{-1}})(R_{\alpha,\beta})]^{-1}$;
- (g) $\varepsilon(u_1) = 1$.

Proof. We adapt the methods used in [8] to our setting. Let us prove Parts (a) and (b). We first show that for all $x \in H_\alpha$,

$$(2.8) \quad S_{\alpha^{-1}}S_\alpha(\varphi_\alpha(x))u_\alpha = u_\alpha x.$$

Write $R_{\alpha,\alpha^{-1}} = a_\alpha \otimes b_{\alpha^{-1}}$ so that $u_\alpha = S_{\alpha^{-1}}(\varphi_\alpha(b_{\alpha^{-1}}))a_\alpha$. Let $x \in H_\alpha$. Using (1.1) and (2.5), we have that

$$(R_{\alpha,\alpha^{-1}})_{12\alpha} \cdot (\text{id}_{H_\alpha} \otimes \Delta_{\alpha^{-1},\alpha})\Delta_{\alpha,1}(x) = (\sigma_{\alpha^{-1},\alpha}(\varphi_{\alpha^{-1}} \otimes \text{id}_{H_\alpha})\Delta_{\alpha^{-1},\alpha} \otimes \text{id}_{H_\alpha})\Delta_{1,\alpha}(x) \cdot (R_{\alpha,\alpha^{-1}})_{12\alpha},$$

that is, $a_\alpha x_{(1,\alpha)} \otimes b_{\alpha^{-1}} x_{(2,\alpha^{-1})} \otimes x_{(3,\alpha)} = x_{(2,\alpha)} a_\alpha \otimes \varphi_{\alpha^{-1}}(x_{(1,\alpha^{-1})}) b_{\alpha^{-1}} \otimes x_{(3,\alpha)}$. Evaluate both sides of this equality with $(\text{id}_{H_\alpha} \otimes S_{\alpha^{-1}}\varphi_\alpha \otimes S_{\alpha^{-1}}S_\alpha\varphi_\alpha)$, reverse the order of the tensorands and multiply them to obtain

$$S_{\alpha^{-1}}S_\alpha\varphi_\alpha(x_{(3,\alpha)})S_{\alpha^{-1}}\varphi_\alpha(b_{\alpha^{-1}}x_{(2,\alpha^{-1})})a_\alpha x_{(1,\alpha)} = S_{\alpha^{-1}}S_\alpha\varphi_\alpha(x_{(3,\alpha)})S_{\alpha^{-1}}\varphi_\alpha(\varphi_{\alpha^{-1}}(x_{(1,\alpha^{-1})})b_{\alpha^{-1}})x_{(2,\alpha)}a_\alpha.$$

Now, by Lemmas 1.1(a) and 2.1(c), the left-hand side is equal to

$$\begin{aligned} & S_{\alpha^{-1}}\varphi_\alpha S_\alpha(x_{(3,\alpha)})S_{\alpha^{-1}}\varphi_\alpha(x_{(2,\alpha^{-1})})S_{\alpha^{-1}}(\varphi_\alpha(b_{\alpha^{-1}}))a_\alpha x_{(1,\alpha)} \\ &= S_{\alpha^{-1}}\varphi_\alpha(x_{(2,\alpha^{-1})})S_\alpha(x_{(3,\alpha)})u_\alpha x_{(1,\alpha)} \\ &= S_{\alpha^{-1}}\varphi_\alpha(\varepsilon(x_{(2,1)})1_{\alpha^{-1}})u_\alpha x_{(1,\alpha)} \quad \text{by (1.5)} \\ &= u_\alpha \varepsilon(x_{(2,1)})x_{(1,\alpha)} \quad \text{since } S_{\alpha^{-1}}\varphi_\alpha(1_{\alpha^{-1}}) = 1_\alpha \\ &= u_\alpha x \quad \text{by (1.2),} \end{aligned}$$

and, by Lemma 1.1(a), the right-hand side is equal to

$$\begin{aligned} & S_{\alpha^{-1}}S_\alpha\varphi_\alpha(x_{(3,\alpha)})S_{\alpha^{-1}}(\varphi_\alpha(b_{\alpha^{-1}}))S_{\alpha^{-1}}(x_{(1,\alpha^{-1})})x_{(2,\alpha)}a_\alpha \\ &= S_{\alpha^{-1}}S_\alpha\varphi_\alpha(\varepsilon(x_{(1,1)})x_{(2,\alpha)})S_{\alpha^{-1}}(\varphi_\alpha(b_{\alpha^{-1}}))a_\alpha \quad \text{by (1.5)} \\ &= S_{\alpha^{-1}}S_\alpha\varphi_\alpha(x)u_\alpha \quad \text{by (1.2).} \end{aligned}$$

Thus (2.8) is proven. Let us show that u_α is invertible. Set

$$\tilde{u}_\alpha = m_\alpha(\text{id}_{H_\alpha} \otimes S_{\alpha^{-1}}S_\alpha)\sigma_{\alpha,\alpha}(R_{\alpha,\alpha}) \in H_\alpha.$$

By Lemma 2.4(b) and (2.7), $R_{\alpha,\alpha} = (\text{id}_{H_\alpha} \otimes S_{\alpha^{-1}})(\varphi_\alpha \otimes \varphi_\alpha)(R_{\alpha,\alpha^{-1}}^{-1})$. Write $R_{\alpha,\alpha^{-1}}^{-1} = c_\alpha \otimes d_{\alpha^{-1}}$. Then $\tilde{u}_\alpha = S_{\alpha^{-1}}(\varphi_\alpha(d_{\alpha^{-1}}))S_{\alpha^{-1}}S_\alpha(\varphi_\alpha(c_\alpha))$ and $a_\alpha c_\alpha \otimes b_{\alpha^{-1}} d_{\alpha^{-1}} = 1_\alpha \otimes 1_{\alpha^{-1}}$. Now

$$\begin{aligned} \tilde{u}_\alpha u_\alpha &= S_{\alpha^{-1}}(\varphi_\alpha(d_{\alpha^{-1}}))S_{\alpha^{-1}}S_\alpha(\varphi_\alpha(c_\alpha))u_\alpha \\ &= S_{\alpha^{-1}}(\varphi_\alpha(d_{\alpha^{-1}}))u_\alpha c_\alpha \quad \text{by (2.8) with } x = c_\alpha \\ &= S_{\alpha^{-1}}(\varphi_\alpha(d_{\alpha^{-1}}))S_{\alpha^{-1}}(\varphi_\alpha(b_{\alpha^{-1}}))a_\alpha c_\alpha \\ &= S_{\alpha^{-1}}(\varphi_\alpha(b_{\alpha^{-1}}d_{\alpha^{-1}}))a_\alpha c_\alpha \quad \text{by Lemma 1.1(a)} \\ &= S_{\alpha^{-1}}(\varphi_\alpha(1_{\alpha^{-1}}))1_\alpha = 1_\alpha. \end{aligned}$$

It can be shown similarly that $u_\alpha \tilde{u}_\alpha = 1_\alpha$. Thus u_α is invertible, $u_\alpha^{-1} = \tilde{u}_\alpha$, and so $S_{\alpha^{-1}}S_\alpha(\varphi_\alpha(x)) = u_\alpha x u_\alpha^{-1}$ for any $x \in H_\alpha$.

Part (c) is a direct consequence of Part (b). Part (d) follows from (2.1), (2.4), and (2.7). Let us show Part (e). For any $x \in H_\alpha$,

$$\begin{aligned}
& S_{\alpha^{-1}}(u_{\alpha^{-1}})u_\alpha\varphi_{\alpha^{-1}}(x) \\
&= S_{\alpha^{-1}}(u_{\alpha^{-1}})S_{\alpha^{-1}}S_\alpha(x)u_\alpha \quad \text{by Part (b)} \\
&= S_{\alpha^{-1}}(u_{\alpha^{-1}})S_{\alpha^{-1}}S_\alpha S_{\alpha^{-1}}(\varphi_{\alpha^{-1}}S_{\alpha^{-1}}^{-1}(\varphi_\alpha(x)))u_\alpha \quad \text{by Lemma 2.1(c)} \\
&= S_{\alpha^{-1}}(u_{\alpha^{-1}})S_{\alpha^{-1}}(u_{\alpha^{-1}}S_{\alpha^{-1}}^{-1}(\varphi_\alpha(x))u_{\alpha^{-1}})u_\alpha \quad \text{by Part (b)} \\
&= \varphi_\alpha(x)S_{\alpha^{-1}}(u_{\alpha^{-1}})u_\alpha \quad \text{since } S_{\alpha^{-1}} \text{ is anti-multiplicative.}
\end{aligned}$$

In particular, for $x = u_\alpha$, one gets that $S_{\alpha^{-1}}(u_{\alpha^{-1}})u_\alpha = u_\alpha S_{\alpha^{-1}}(u_{\alpha^{-1}})$.

For the proof of the first equality of Part (f), set $\widetilde{R}_{\alpha,\beta} = \sigma_{\beta,\alpha}(\text{id}_{H_\beta} \otimes \varphi_\alpha)(R_{\beta,\alpha})$. By Lemma 2.1 and (2.7), we have also that $\widetilde{R}_{\alpha,\beta} = \sigma_{\beta,\alpha}(\varphi_{\alpha^{-1}} \otimes \text{id}_{H_\alpha})(R_{\alpha\beta\alpha^{-1},\alpha})$. We first show that for all $x \in H_{\alpha\beta}$,

$$(2.9) \quad \widetilde{R}_{\alpha,\beta} \cdot R_{\alpha,\beta} \cdot \Delta_{\alpha,\beta}(x) = (\varphi_\alpha \otimes \varphi_\beta)\Delta_{\alpha,\beta}(\varphi_{(\alpha\beta)^{-1}}(x)) \cdot \widetilde{R}_{\alpha,\beta} \cdot R_{\alpha,\beta}.$$

By (2.5), $R_{\beta,\alpha} \cdot \Delta_{\beta,\alpha}(\varphi_{\alpha^{-1}}(x)) = \sigma_{\alpha,\beta}(\varphi_{\beta^{-1}} \otimes \text{id}_{H_\beta})\Delta_{\beta\alpha\beta^{-1},\beta}(\varphi_{\alpha^{-1}}(x)) \cdot R_{\beta,\alpha}$. Evaluate both sides of this equality with the algebra homomorphism $\sigma_{\beta,\alpha}(\text{id}_{H_\beta} \otimes \varphi_\alpha)$ and multiply them on the right by $R_{\alpha,\beta}$ to obtain

$$\begin{aligned}
& \sigma_{\beta,\alpha}(\text{id}_{H_\beta} \otimes \varphi_\alpha)(R_{\beta,\alpha}) \cdot \sigma_{\beta,\alpha}(\text{id}_{H_\beta} \otimes \varphi_\alpha)\Delta_{\beta,\alpha}(\varphi_{\alpha^{-1}}(x)) \cdot R_{\alpha,\beta} \\
&= (\varphi_\alpha\varphi_{\beta^{-1}} \otimes \text{id}_{H_\beta})\Delta_{\beta\alpha\beta^{-1},\beta}(\varphi_{\alpha^{-1}}(x)) \cdot \sigma_{\beta,\alpha}(\text{id}_{H_\beta} \otimes \varphi_\alpha)(R_{\beta,\alpha}) \cdot R_{\alpha,\beta}.
\end{aligned}$$

Then, using (2.2), (2.4), and (2.5), one gets equality (2.9). Set now

$$\mathcal{E} = \widetilde{R}_{\alpha,\beta} \cdot R_{\alpha,\beta} \cdot \Delta_{\alpha,\beta}(u_{\alpha\beta}).$$

We have to show that $\mathcal{E} = u_\alpha \otimes u_\beta$. Write $R_{\alpha\beta,(\alpha\beta)^{-1}} = r \otimes s$, $R_{\alpha,\beta} = a_\alpha \otimes b_\beta$, and $\widetilde{R}_{\alpha,\beta} = c_\alpha \otimes d_\beta$. Then $u_{\alpha\beta} = S_{(\alpha\beta)^{-1}}(\varphi_{\alpha\beta}(s))r = \varphi_{\alpha\beta}S_{(\alpha\beta)^{-1}}(s)r$. We have that

$$\begin{aligned}
\mathcal{E} &= \widetilde{R}_{\alpha,\beta} \cdot R_{\alpha,\beta} \cdot \Delta_{\alpha,\beta}(\varphi_{\alpha\beta}S_{(\alpha\beta)^{-1}}(s)r) \\
&= \widetilde{R}_{\alpha,\beta} \cdot R_{\alpha,\beta} \cdot \Delta_{\alpha,\beta}(\varphi_{\alpha\beta}S_{(\alpha\beta)^{-1}}(s)) \cdot \Delta_{\alpha,\beta}(r) \quad \text{by (1.4)}.
\end{aligned}$$

Therefore, using (2.9) for $x = \varphi_{\alpha\beta}S_{(\alpha\beta)^{-1}}(s)$ and then Lemmas 1.1(c) and 2.1(c), we obtain that

$$\begin{aligned}
\mathcal{E} &= (\varphi_\alpha \otimes \varphi_\beta) \cdot \Delta_{\alpha,\beta}(S_{(\alpha\beta)^{-1}}(s)) \cdot \widetilde{R}_{\alpha,\beta} \cdot R_{\alpha,\beta} \cdot \Delta_{\alpha,\beta}(r) \\
&= (\varphi_\alpha \otimes \varphi_\beta)\sigma_{\beta,\alpha}(S_{\beta^{-1}} \otimes S_{\alpha^{-1}})\Delta_{\beta^{-1},\alpha^{-1}}(s) \cdot \widetilde{R}_{\alpha,\beta} \cdot R_{\alpha,\beta} \cdot \Delta_{\alpha,\beta}(r) \\
&= \varphi_\alpha S_{\alpha^{-1}}(s_{(2,\alpha^{-1})})c_\alpha a_\alpha r_{(1,\alpha)} \otimes \varphi_\beta S_{\beta^{-1}}(s_{(1,\beta^{-1})})d_\beta b_\beta r_{(2,\beta)} \\
&= S_{\alpha^{-1}}(\varphi_\alpha(s_{(2,\alpha^{-1})}))c_\alpha a_\alpha r_{(1,\alpha)} \otimes S_{\beta^{-1}}(\varphi_\beta(s_{(1,\beta^{-1})}))d_\beta b_\beta r_{(2,\beta)}.
\end{aligned}$$

Now $H_\alpha \otimes H_\beta$ is a right $H_\alpha \otimes H_\beta \otimes H_{\alpha^{-1}} \otimes H_{\beta^{-1}}$ -module under the action

$$(x \otimes y) \leftarrow (h_1 \otimes h_2 \otimes h_3 \otimes h_4) = S_{\alpha^{-1}}(\varphi_\alpha(h_3))xh_1 \otimes S_{\beta^{-1}}(\varphi_\beta(h_4))yh_2.$$

For any \mathbb{k} -spaces P, Q and any $x = \sum_j p_j \otimes q_j \in P \otimes Q$, we set $x_{12\alpha\beta} = x \otimes 1_\alpha \otimes 1_\beta \in P \otimes Q \otimes H_\alpha \otimes H_\beta$, $x_{\alpha 2\beta 4} = \sum_j 1_\alpha \otimes p_j \otimes 1_\beta \otimes q_j \in H_\alpha \otimes P \otimes H_\beta \otimes Q$, etc. Then

$$\begin{aligned}
\mathcal{E} &= c_\alpha \otimes d_\beta \leftarrow a_\alpha r_{(1,\alpha)} \otimes b_\beta r_{(2,\alpha^{-1})} \otimes s_{(2,\alpha^{-1})} \otimes s_{(1,\beta^{-1})} \\
&= \widetilde{R}_{\alpha,\beta} \leftarrow (R_{\alpha,\beta})_{12\alpha^{-1}\beta^{-1}} \cdot (\Delta_{\alpha,\beta} \otimes \sigma_{\beta^{-1},\alpha^{-1}}\Delta_{\beta^{-1},\alpha^{-1}})(R_{\alpha\beta,(\alpha\beta)^{-1}}) \\
&= \widetilde{R}_{\alpha,\beta} \leftarrow (R_{\alpha,\beta})_{12\alpha^{-1}\beta^{-1}} \cdot (\Delta_{\alpha,\beta} \otimes \text{id}_{H_{\alpha^{-1}}} \otimes \text{id}_{H_{\beta^{-1}}}) \\
&\quad \cdot ((R_{\alpha\beta,\alpha^{-1}})_{12\beta^{-1}} \cdot (R_{\alpha\beta,\beta^{-1}})_{1\alpha^{-1}3}) \quad \text{by (2.6)} \\
&= \widetilde{R}_{\alpha,\beta} \leftarrow (R_{\alpha,\beta})_{12\alpha^{-1}\beta^{-1}} \cdot (\Delta_{\alpha,\beta} \otimes \text{id}_{H_{\alpha^{-1}}} \otimes \text{id}_{H_{\beta^{-1}}})((R_{\alpha\beta,\alpha^{-1}})_{12\beta^{-1}} \\
&\quad \cdot (\Delta_{\alpha,\beta} \otimes \text{id}_{H_{\alpha^{-1}}} \otimes \text{id}_{H_{\beta^{-1}}})(R_{\alpha\beta,\beta^{-1}})_{1\alpha^{-1}3}) \quad \text{by (1.4)}.
\end{aligned}$$

Therefore, by (2.6) and Lemma 2.4(d),

$$\begin{aligned}\mathcal{E} &= \widetilde{R}_{\alpha,\beta} \leftarrow (R_{\alpha,\beta})_{12\alpha^{-1}\beta^{-1}} \cdot [(\text{id}_{H_\alpha} \otimes \varphi_{\beta^{-1}})(R_{\alpha,\beta\alpha^{-1}\beta^{-1}})]_{1\beta 3\beta^{-1}} \\ &\quad \cdot (R_{\beta,\alpha^{-1}})_{\alpha 23\beta^{-1}} \cdot [(\text{id}_{H_\alpha} \otimes \varphi_{\beta^{-1}})(R_{\alpha,\beta^{-1}})]_{1\beta\alpha^{-1}4} \cdot (R_{\beta,\beta^{-1}})_{\alpha 2\alpha^{-1}4} \\ &= \widetilde{R}_{\alpha,\beta} \leftarrow (R_{\beta,\alpha^{-1}})_{\alpha 23\beta^{-1}} \cdot (R_{\alpha,\alpha^{-1}})_{1\beta 3\beta^{-1}} \cdot (R_{\alpha,\beta})_{12\alpha^{-1}\beta^{-1}} \\ &\quad \cdot [(\text{id}_{H_\alpha} \otimes \varphi_{\beta^{-1}})(R_{\alpha,\beta^{-1}})]_{1\beta\alpha^{-1}4} \cdot (R_{\beta,\beta^{-1}})_{\alpha 2\alpha^{-1}4}.\end{aligned}$$

Write $R_{\beta,\alpha} = e_\beta \otimes f_\alpha$ and $R_{\beta,\alpha^{-1}} = h_\beta \otimes k_{\alpha^{-1}}$. Then $\widetilde{R}_{\alpha,\beta} = \varphi_\alpha(f_\alpha) \otimes e_\beta$ and so

$$\begin{aligned}\widetilde{R}_{\alpha,\beta} &\leftarrow (R_{\beta,\alpha^{-1}})_{\alpha 23\beta^{-1}} \\ &= S_{\alpha^{-1}}(\varphi_\alpha(k_{\alpha^{-1}}))\varphi_\alpha(f_\alpha) \otimes e_\beta h_\beta \\ &= \sigma_{\beta,\alpha}(\text{id}_{H_\beta} \otimes \varphi_\alpha S_{\alpha^{-1}})((\text{id}_{H_\beta} \otimes S_{\alpha^{-1}}^{-1})(R_{\beta,\alpha}) \cdot R_{\beta,\alpha^{-1}}) \quad \text{by Lemma 2.1(c)} \\ &= \sigma_{\beta,\alpha}(\text{id}_{H_\beta} \otimes \varphi_\alpha S_{\alpha^{-1}})(R_{\beta,\alpha^{-1}}^{-1} \cdot R_{\beta,\alpha^{-1}}) \quad \text{by Lemma 2.4(b)} \\ &= 1_\alpha \otimes 1_\beta.\end{aligned}$$

Writing $R_{\alpha,\alpha^{-1}} = m_\alpha \otimes n_{\alpha^{-1}}$, we obtain

$$1_\alpha \otimes 1_\beta \leftarrow (R_{\alpha,\alpha^{-1}})_{1\alpha^{-1}3\beta^{-1}} = S_{\alpha^{-1}}\varphi_\alpha(n_{\alpha^{-1}})m_\alpha \otimes 1_\beta = u_\alpha \otimes 1_\beta.$$

Therefore

$$\mathcal{E} = u_\alpha \otimes 1_\beta \leftarrow (R_{\alpha,\beta})_{12\alpha^{-1}\beta^{-1}} \cdot [(\text{id}_{H_\alpha} \otimes \varphi_{\beta^{-1}})(R_{\alpha,\beta^{-1}})]_{1\beta\alpha^{-1}4} \cdot (R_{\beta,\beta^{-1}})_{\alpha 2\alpha^{-1}4}.$$

Write now $R_{\alpha,\beta^{-1}} = p_\alpha \otimes q_{\beta^{-1}}$. Then

$$\begin{aligned}u_\alpha \otimes 1_\beta &\leftarrow (R_{\alpha,\beta})_{12\alpha^{-1}\beta^{-1}} \cdot [(\text{id}_{H_\alpha} \otimes \varphi_{\beta^{-1}})(R_{\alpha,\beta^{-1}})]_{1\beta\alpha^{-1}4} \\ &= u_\alpha a_\alpha p_\alpha \otimes S_{\beta^{-1}}(q_{\beta^{-1}})b_\beta \\ &= (u_\alpha \otimes 1_\beta) \cdot (\text{id}_{H_\alpha} \otimes S_{\beta^{-1}})((\text{id}_{H_\alpha} \otimes S_{\beta^{-1}}^{-1})(R_{\alpha,\beta}) \cdot R_{\alpha,\beta^{-1}}) \\ &= (u_\alpha \otimes 1_\beta) \cdot (\text{id}_{H_\alpha} \otimes S_{\beta^{-1}})(R_{\alpha,\beta^{-1}}^{-1} \cdot R_{\alpha,\beta^{-1}}) \quad \text{by Lemma 2.4(b)} \\ &= u_\alpha \otimes 1_\beta.\end{aligned}$$

Hence $\mathcal{E} = u_\alpha \otimes 1_\beta \leftarrow (R_{\beta,\beta^{-1}})_{\alpha 2\alpha^{-1}4}$. Finally, write $R_{\beta,\beta^{-1}} = x_\beta \otimes y_{\beta^{-1}}$. Then $\mathcal{E} = u_\alpha \otimes S_{\beta^{-1}}(\varphi_\beta(y_{\beta^{-1}}))x_\beta = u_\alpha \otimes u_\beta$. This completes the proof of the first equality of Part (f). Let us show the second one. Using the first equality of Part (f) and then Part (b), we have that

$$\begin{aligned}\Delta_{\alpha,\beta}(u_{\alpha\beta}) &= [\sigma_{\beta,\alpha}(\text{id}_{H_\beta} \otimes \varphi_\alpha)(R_{\beta,\alpha}) \cdot R_{\alpha,\beta}]^{-1} \cdot (u_\alpha \otimes u_\beta) \\ &= (u_\alpha \otimes u_\beta) \cdot (\varphi_{\alpha^{-1}}(S_{\alpha^{-1}}S_\alpha)^{-1} \otimes \varphi_{\beta^{-1}}(S_{\beta^{-1}}S_\beta)^{-1}) \\ &\quad ([\sigma_{\beta,\alpha}(\text{id}_{H_\beta} \otimes \varphi_\alpha)(R_{\beta,\alpha}) \cdot R_{\alpha,\beta}]^{-1}),\end{aligned}$$

and so, by Lemmas 2.1 and 2.4(c),

$$\Delta_{\alpha,\beta}(u_{\alpha\beta}) = (u_\alpha \otimes u_\beta) \cdot [\sigma_{\beta,\alpha}(\varphi_{\beta^{-1}} \otimes \text{id}_{H_\alpha})(R_{\beta,\alpha}) \cdot (\varphi_{\alpha^{-1}} \otimes \varphi_{\beta^{-1}})(R_{\alpha,\beta})]^{-1}.$$

It remains to show Part (g). We have

$$\begin{aligned}u_1 &= (\varepsilon \otimes \text{id}_{H_1})\Delta_{1,1}(u_1) \quad \text{by (1.2)} \\ &= (\varepsilon \otimes \text{id}_{H_1})((\sigma_{1,1}(R_{1,1}) \cdot R_{1,1})^{-1} \cdot (u_1 \otimes u_1)) \quad \text{by Part (f)} \\ &= (\varepsilon \otimes \text{id}_{H_1})(R_{1,1})^{-1} \cdot (\text{id}_{H_1} \otimes \varepsilon)(R_{1,1})^{-1} \cdot \varepsilon(u_1)u_1 \quad \text{by (1.4)} \\ &= \varepsilon(u_1)u_1 \quad \text{by Lemma 2.4(a)}.\end{aligned}$$

Now $u_1 \neq 0$ since u_1 is invertible (by Part (a)) and $H_1 \neq 0$ (by Corollary 1.2). Hence $\varepsilon(u_1) = 1$. This finishes the proof of the lemma. \square

2.1.3.1. The coopposite Hopf π -coalgebra. Let $H = \{H_\alpha\}_{\alpha \in \pi}$ be a quasitriangular Hopf π -coalgebra with R -matrix $R = \{R_{\alpha,\beta}\}_{\alpha,\beta \in \pi}$. By Lemma 2.5(c), the antipode of H is bijective. Thus we can consider the coopposite crossed Hopf π -coalgebra H^{cop} to H (see §2.1.1.1). It is quasitriangular by setting $R_{\alpha,\beta}^{\text{cop}} = (\varphi_\alpha \otimes \text{id}_{H_{\beta^{-1}}})(R_{\alpha^{-1},\beta^{-1}}^{-1}) = (S_\alpha \otimes \text{id}_{H_{\beta^{-1}}})(R_{\alpha,\beta^{-1}})$. The Drinfeld elements of H and H^{cop} are related by $u_\alpha^{\text{cop}} = u_{\alpha^{-1}}^{-1}$.

2.1.3.2. The mirror Hopf π -coalgebra. Let $H = \{H_\alpha\}_{\alpha \in \pi}$ be a quasitriangular Hopf π -coalgebra with R -matrix $R = \{R_{\alpha,\beta}\}_{\alpha,\beta \in \pi}$. Following [48, §11.6], the mirror crossed Hopf π -coalgebra \overline{H} to H (see §2.1.1.2) is quasitriangular with R -matrix given by $\overline{R}_{\alpha,\beta} = \sigma_{\beta^{-1},\alpha^{-1}}(R_{\beta^{-1},\alpha^{-1}}^{-1})$. The Drinfeld elements associated to H and \overline{H} verify $\overline{u}_\alpha = S_\alpha(u_\alpha)^{-1}$.

The following corollary of Lemma 2.5 will be used in Section 2.1.4 to compute the distinguished π -grouplike element from the R -matrix.

COROLLARY 2.6. *Let $H = \{H_\alpha\}_{\alpha \in \pi}$ be a quasitriangular Hopf π -coalgebra. For all $\alpha \in \pi$, set $\ell_\alpha = S_{\alpha^{-1}}(u_{\alpha^{-1}})^{-1}u_\alpha = u_\alpha S_{\alpha^{-1}}(u_{\alpha^{-1}})^{-1} \in H_\alpha$. Then*

- (a) $\ell = (\ell_\alpha)_{\alpha \in \pi}$ is a π -grouplike element of H ;
- (b) $(S_{\alpha^{-1}}S_\alpha)^2(x) = \ell_\alpha x \ell_\alpha^{-1}$ for all $\alpha \in \pi$ and $x \in H_\alpha$.

Proof. Let us show Part (a). Denote by \overline{u}_α the Drinfeld elements of the mirror Hopf π -coalgebra \overline{H} to H (see §2.1.3.2). Since $\overline{u}_\alpha = S_\alpha(u_\alpha)^{-1}$, Lemma 2.5(f) applied to \overline{H} gives that, for any $\alpha, \beta \in \pi$,

$$\begin{aligned} \Delta_{\alpha,\beta}(S_{(\alpha\beta)^{-1}}(u_{(\alpha\beta)^{-1}})^{-1}) &= \sigma_{\beta,\alpha}(\varphi_{\beta^{-1}} \otimes \text{id}_{H_\alpha})(R_{\beta,\alpha}) \\ &\quad \cdot (\varphi_{\alpha^{-1}} \otimes \varphi_{\beta^{-1}})(R_{\alpha,\beta}) \cdot (S_{\alpha^{-1}}(u_{\alpha^{-1}})^{-1} \otimes S_{\beta^{-1}}(u_{\beta^{-1}})^{-1}). \end{aligned}$$

Now, by Lemma 2.5(f),

$$\Delta_{\alpha,\beta}(u_{\alpha\beta}) = (u_\alpha \otimes u_\beta) \cdot [\sigma_{\beta,\alpha}(\varphi_{\beta^{-1}} \otimes \text{id}_{H_\alpha})(R_{\beta,\alpha}) \cdot (\varphi_{\alpha^{-1}} \otimes \varphi_{\beta^{-1}})(R_{\alpha,\beta})]^{-1}.$$

Thus we obtain that $\Delta_{\alpha,\beta}(\ell_{\alpha\beta}) = \Delta_{\alpha,\beta}(u_{\alpha\beta}) \cdot \Delta_{\alpha,\beta}(S_{(\alpha\beta)^{-1}}(u_{(\alpha\beta)^{-1}})^{-1}) = \ell_\alpha \otimes \ell_\beta$. Moreover $\varepsilon(\ell_1) = \varepsilon(u_1 S_1(u_1)^{-1}) = \varepsilon(u_1)\varepsilon(S_1(u_1))^{-1} = \varepsilon(u_1)\varepsilon(u_1)^{-1} = 1$ by (1.4) and Lemma 1.1(d). Hence $\ell = (\ell_\alpha)_{\alpha \in \pi} \in G(H)$.

To show Part (b), let $\alpha \in \pi$ and $x \in H_\alpha$. Applying Lemma 2.5(b) to \overline{H} and then to H gives that

$$\begin{aligned} (S_{\alpha^{-1}}S_\alpha)^2(x) &= S_{\alpha^{-1}}S_\alpha(S_{\alpha^{-1}}(u_{\alpha^{-1}})^{-1}\varphi_\alpha(x)S_{\alpha^{-1}}(u_{\alpha^{-1}})) \\ &= S_{\alpha^{-1}}S_\alpha(S_{\alpha^{-1}}(u_{\alpha^{-1}})^{-1})S_{\alpha^{-1}}S_\alpha(\varphi_\alpha(x))S_{\alpha^{-1}}S_\alpha(S_{\alpha^{-1}}(u_{\alpha^{-1}})) \\ &= u_\alpha S_{\alpha^{-1}}(u_{\alpha^{-1}})^{-1}xS_{\alpha^{-1}}(u_{\alpha^{-1}})u_\alpha^{-1} \\ &= \ell_\alpha x \ell_\alpha^{-1}. \end{aligned}$$

This completes the proof of the corollary. \square

2.1.3.3. The double of a crossed Hopf π -coalgebra. The Drinfeld double construction for Hopf algebras can be extended to the setting of crossed Hopf π -coalgebras, see [52]. This yields examples of quasitriangular Hopf π -coalgebras.

2.1.4. The distinguished π -grouplike element from the R -matrix. In this subsection, we show that the distinguished π -grouplike element of a finite type quasitriangular Hopf π -coalgebra can be computed by using the R -matrix. This generalizes [38, THEOREM 2].

THEOREM 2.7. *Let $H = \{H_\alpha\}_{\alpha \in \pi}$ be a finite type quasitriangular Hopf π -coalgebra. Let $g = (g_\alpha)_{\alpha \in \pi}$ be the distinguished π -grouplike element of H , ν be the distinguished grouplike element of H_1^* , $\ell = (\ell_\alpha)_{\alpha \in \pi} \in G(H)$ be as in Corollary 2.6, and $\widehat{\varphi}$ be as in Corollary 2.2. We define $h_\alpha = (\text{id}_{H_\alpha} \otimes \nu)(R_{\alpha,1})$ for any $\alpha \in \pi$. Then*

- (a) $h = (h_\alpha)_{\alpha \in \pi}$ is a π -grouplike element of H ;
- (b) $g = \widehat{\varphi}^{-1} \ell h$ in $G(H)$, i.e., $g_\alpha = \widehat{\varphi}(\alpha)^{-1} \ell_\alpha h_\alpha$ for all $\alpha \in \pi$.

Proof. We adapt the technique used in the proof of [38, THEOREM 2]. Let us first show Part (a). For any $\alpha, \beta \in \pi$, using (2.6), the multiplicativity of ν , and Lemma 2.3(b), we have that

$$\begin{aligned} \Delta_{\alpha,\beta}(h_{\alpha\beta}) &= (\Delta_{\alpha,\beta} \otimes \nu)(R_{\alpha\beta,1}) \\ &= (\text{id}_{H_\alpha} \otimes \text{id}_{H_\beta} \otimes \nu)((\text{id}_{H_\alpha} \otimes \varphi_{\beta^{-1}})(R_{\alpha,1})]_{1\beta 3} \cdot (R_{\beta,1})_{\alpha 2 3}) \\ &= ((\text{id}_{H_\alpha} \otimes \nu \varphi_{\beta^{-1}})(R_{\alpha,1}) \otimes 1_\beta) \cdot (1_\alpha \otimes (\text{id}_{H_\beta} \otimes \nu)(R_{\beta,1})) \\ &= ((\text{id}_{H_\alpha} \otimes \nu)(R_{\alpha,1}) \otimes 1_\beta) \cdot (1_\alpha \otimes h_\beta) \\ &= h_\alpha \otimes h_\beta. \end{aligned}$$

Moreover, using Lemma 2.4(a), $\varepsilon(h_1) = (\varepsilon \otimes \nu)(R_{1,1}) = \nu(1_1) = 1$. Thus $h \in G(H)$.

To show Part (b), let $\alpha \in \pi$ and Λ be a non-zero left integral for H_1 . We first show that, for any $x \in H_{\alpha^{-1}}$,

$$(2.10) \quad \Lambda_{(1,\alpha)} \otimes x \Lambda_{(2,\alpha^{-1})} = S_{\alpha^{-1}}(x) \Lambda_{(1,\alpha)} \otimes \Lambda_{(2,\alpha^{-1})}$$

and

$$(2.11) \quad \Lambda_{(1,\alpha^{-1})} x \otimes \Lambda_{(2,\alpha)} = \Lambda_{(1,\alpha^{-1})} \otimes \Lambda_{(2,\alpha)} S_{\alpha^{-1}}(x \leftarrow \nu).$$

Indeed

$$\begin{aligned} \Lambda_{(1,\alpha)} \otimes x \Lambda_{(2,\alpha^{-1})} &= \varepsilon(x_{(1,1)}) \Lambda_{(1,\alpha)} \otimes x_{(2,\alpha^{-1})} \Lambda_{(2,\alpha^{-1})} \quad \text{by (1.2)} \\ &= S_{\alpha^{-1}}(x_{(1,\alpha^{-1})}) x_{(2,\alpha)} \Lambda_{(1,\alpha)} \otimes x_{(3,\alpha^{-1})} \Lambda_{(2,\alpha^{-1})} \quad \text{by (1.5)} \\ &= S_{\alpha^{-1}}(x_{(1,\alpha^{-1})}) (x_{(2,1)} \Lambda)_{(1,\alpha)} \otimes (x_{(2,1)} \Lambda)_{(2,\alpha^{-1})} \quad \text{by (1.4)}, \end{aligned}$$

and so, since Λ is a left integral for H_1 ,

$$\begin{aligned} \Lambda_{(1,\alpha)} \otimes x \Lambda_{(2,\alpha^{-1})} &= S_{\alpha^{-1}}(x_{(1,\alpha^{-1})} \varepsilon(x_{(2,1)})) \Lambda_{(1,\alpha)} \otimes \Lambda_{(2,\alpha^{-1})} \\ &= S_{\alpha^{-1}}(x) \Lambda_{(1,\alpha)} \otimes \Lambda_{(2,\alpha^{-1})} \quad \text{by (1.2)}. \end{aligned}$$

Similarly,

$$\begin{aligned} \Lambda_{(1,\alpha^{-1})} x \otimes \Lambda_{(2,\alpha)} &= \Lambda_{(1,\alpha^{-1})} x_{(1,\alpha^{-1})} \otimes \Lambda_{(2,\alpha)} \varepsilon(x_{(2,1)}) \quad \text{by (1.2)} \\ &= \Lambda_{(1,\alpha^{-1})} x_{(1,\alpha^{-1})} \otimes \Lambda_{(2,\alpha)} x_{(2,\alpha)} S_{\alpha^{-1}}(x_{(3,\alpha^{-1})}) \quad \text{by (1.5)} \\ &= (\Lambda x_{(1,1)})_{(1,\alpha^{-1})} \otimes (\Lambda x_{(1,1)})_{(2,\alpha)} S_{\alpha^{-1}}(x_{(2,\alpha^{-1})}) \quad \text{by (1.4)}, \end{aligned}$$

and so, since Λ is a left integral for H_1 ,

$$\begin{aligned} \Lambda_{(1,\alpha^{-1})} x \otimes \Lambda_{(2,\alpha)} &= \Lambda_{(1,\alpha^{-1})} \otimes \Lambda_{(2,\alpha)} S_{\alpha^{-1}}(\nu(x_{(1,1)}) x_{(2,\alpha^{-1})}) \\ &= \Lambda_{(1,\alpha^{-1})} \otimes \Lambda_{(2,\alpha)} S_{\alpha^{-1}}(x \leftarrow \nu). \end{aligned}$$

Write $R_{\alpha,\alpha^{-1}} = a_\alpha \otimes b_{\alpha^{-1}}$. Recall that $u_\alpha = S_{\alpha^{-1}} \varphi_\alpha(b_{\alpha^{-1}}) a_\alpha$. By Lemma 2.4(c) and (2.7), $R_{\alpha^{-1},\alpha} = S_\alpha(a_\alpha) \otimes \varphi_\alpha S_{\alpha^{-1}}(b_{\alpha^{-1}})$. Thus $u_{\alpha^{-1}} = S_\alpha S_{\alpha^{-1}}(b_{\alpha^{-1}}) S_\alpha(a_\alpha)$ and so, using Lemma 2.5(b)

and (d), $S_{\alpha^{-1}}(u_{\alpha^{-1}}) = S_{\alpha}^{-1}(u_{\alpha^{-1}}) = a_{\alpha}S_{\alpha^{-1}}(b_{\alpha^{-1}})$. Then

$$\begin{aligned}
& \Lambda_{(2,\alpha)}S_{\alpha^{-1}}(\varphi_{\alpha}(b_{\alpha^{-1}}) \leftarrow \nu)a_{\alpha} \otimes \Lambda_{(1,\alpha^{-1})} \\
&= \Lambda_{(2,\alpha)}a_{\alpha} \otimes \Lambda_{(1,\alpha^{-1})}\varphi_{\alpha}(b_{\alpha^{-1}}) \quad \text{by (2.11) for } x = \varphi_{\alpha}(b_{\alpha^{-1}}) \\
&= (\text{id}_{H_{\alpha}} \otimes \varphi_{\alpha})(\Lambda_{(2,\alpha)}a_{\alpha} \otimes \varphi_{\alpha^{-1}}(\Lambda_{(1,\alpha^{-1})}b_{\alpha^{-1}})) \\
&= (\text{id}_{H_{\alpha}} \otimes \varphi_{\alpha})(a_{\alpha}\Lambda_{(1,\alpha)} \otimes b_{\alpha^{-1}}\Lambda_{(2,\alpha^{-1})}) \quad \text{by (2.5)} \\
&= (\text{id}_{H_{\alpha}} \otimes \varphi_{\alpha})(a_{\alpha}S_{\alpha^{-1}}(b_{\alpha^{-1}})\Lambda_{(1,\alpha)} \otimes \Lambda_{(2,\alpha^{-1})}) \quad \text{by (2.10) for } x = b_{\alpha^{-1}} \\
&= S_{\alpha^{-1}}(u_{\alpha^{-1}})\Lambda_{(1,\alpha)} \otimes \varphi_{\alpha}(\Lambda_{(2,\alpha^{-1})}) \\
&= (\varphi_{\alpha^{-1}} \otimes \text{id}_{H_{\alpha^{-1}}})(\varphi_{\alpha}S_{\alpha^{-1}}(u_{\alpha^{-1}})\varphi_{\alpha}(\Lambda_{(1,\alpha)}) \otimes \varphi_{\alpha}(\Lambda_{(2,\alpha^{-1})})) \quad \text{by (2.4)} \\
&= (\varphi_{\alpha^{-1}} \otimes \text{id}_{H_{\alpha^{-1}}})(\varphi_{\alpha}S_{\alpha^{-1}}(u_{\alpha^{-1}})\varphi_{\alpha}(\Lambda_{(1,\alpha)}) \otimes \varphi_{\alpha}(\Lambda_{(2,\alpha^{-1})})) \quad \text{by (2.2)}.
\end{aligned}$$

Now $\varphi_{\alpha}(\Lambda) = \widehat{\varphi}(\alpha)\Lambda$ by Lemma 2.3(a) and

$$\Lambda_{(1,\alpha)} \otimes \Lambda_{(2,\alpha^{-1})} = S_{\alpha^{-1}}S_{\alpha}(\Lambda_{(2,\alpha)})g_{\alpha} \otimes \Lambda_{(1,\alpha^{-1})}$$

by Corollary 1.18. Therefore

$$\begin{aligned}
& \Lambda_{(2,\alpha)}S_{\alpha^{-1}}(\varphi_{\alpha}(b_{\alpha^{-1}}) \leftarrow \nu)a_{\alpha} \otimes \Lambda_{(1,\alpha^{-1})} \\
&= \widehat{\varphi}(\alpha)(\varphi_{\alpha^{-1}} \otimes \text{id}_{H_{\alpha^{-1}}})(\varphi_{\alpha}S_{\alpha^{-1}}(u_{\alpha^{-1}})S_{\alpha^{-1}}S_{\alpha}(\Lambda_{(2,\alpha)})g_{\alpha} \otimes \Lambda_{(1,\alpha^{-1})}) \\
&= \widehat{\varphi}(\alpha)S_{\alpha^{-1}}(u_{\alpha^{-1}})\varphi_{\alpha^{-1}}S_{\alpha^{-1}}S_{\alpha}(\Lambda_{(2,\alpha)})\varphi_{\alpha^{-1}}(g_{\alpha}) \otimes \Lambda_{(1,\alpha^{-1})} \\
&= \widehat{\varphi}(\alpha)S_{\alpha^{-1}}(u_{\alpha^{-1}})\varphi_{\alpha^{-1}}S_{\alpha^{-1}}S_{\alpha}(\Lambda_{(2,\alpha)})g_{\alpha} \otimes \Lambda_{(1,\alpha^{-1})} \quad \text{by Lemma 2.3(c)}.
\end{aligned}$$

Let $\lambda = (\lambda_{\gamma})_{\gamma \in \pi}$ be right π -integral for H such that $\lambda_1(\Lambda) = 1$ (see the proof of Corollary 1.18). Applying $(\text{id}_{H_{\alpha}} \otimes \lambda_{\alpha^{-1}})$ on both sides of the last equality, we get

$$\lambda_{\alpha^{-1}}(\Lambda_{(1,\alpha^{-1})})\Lambda_{(2,\alpha)}S_{\alpha^{-1}}(\varphi_{\alpha}(b_{\alpha^{-1}}) \leftarrow \nu)a_{\alpha} = \widehat{\varphi}(\alpha)S_{\alpha^{-1}}(u_{\alpha^{-1}})\varphi_{\alpha^{-1}}S_{\alpha^{-1}}S_{\alpha}(\lambda_{\alpha^{-1}}(\Lambda_{(1,\alpha^{-1})})\Lambda_{(2,\alpha)})g_{\alpha},$$

and so, since $\lambda_{\alpha^{-1}}(\Lambda_{(1,\alpha^{-1})})\Lambda_{(2,\alpha)} = \lambda_1(\Lambda)1_{\alpha} = 1_{\alpha}$ by (1.12),

$$(2.12) \quad S_{\alpha^{-1}}(\varphi_{\alpha}(b_{\alpha^{-1}}) \leftarrow \nu)a_{\alpha} = \widehat{\varphi}(\alpha)S_{\alpha^{-1}}(u_{\alpha^{-1}})g_{\alpha}.$$

Write $R_{\alpha,1} = c_{\alpha} \otimes d_1$ so that $h_{\alpha} = \nu(d_1)c_{\alpha}$. Since, by (2.2) and Lemma 2.3(b), $\varphi_{\alpha}(x) \leftarrow \nu = \varphi_{\alpha}(x \leftarrow \nu)$ for all $x \in H_{\alpha^{-1}}$, we have that

$$\begin{aligned}
a_{\alpha} \otimes (\varphi_{\alpha}(b_{\alpha^{-1}}) \leftarrow \nu) &= a_{\alpha} \otimes \varphi_{\alpha}(b_{\alpha^{-1}} \leftarrow \nu) \\
&= (\text{id}_{H_{\alpha}} \otimes \nu \otimes \varphi_{\alpha})(\text{id}_{H_{\alpha}} \otimes \Lambda_{1,\alpha^{-1}})(R_{\alpha,\alpha^{-1}}) \\
&= (\text{id}_{H_{\alpha}} \otimes \nu \otimes \varphi_{\alpha})((R_{\alpha,\alpha^{-1}})_{11\pi 3} \cdot (R_{\alpha,1})_{12\alpha^{-1}}) \quad \text{by (2.6)} \\
&= a_{\alpha}\nu(d_1)c_{\alpha} \otimes \varphi_{\alpha}(b_{\alpha^{-1}}) \\
&= a_{\alpha}h_{\alpha} \otimes \varphi_{\alpha}(b_{\alpha^{-1}}).
\end{aligned}$$

Therefore $S_{\alpha^{-1}}(\varphi_{\alpha}(b_{\alpha^{-1}}) \leftarrow \nu)a_{\alpha} = S_{\alpha^{-1}}(\varphi_{\alpha}(b_{\alpha^{-1}}))a_{\alpha}h_{\alpha} = u_{\alpha}h_{\alpha}$. Finally, comparing with (2.12), we get $\widehat{\varphi}(\alpha)S_{\alpha^{-1}}(u_{\alpha^{-1}})g_{\alpha} = u_{\alpha}h_{\alpha}$. Hence $g_{\alpha} = \widehat{\varphi}(\alpha)^{-1}\ell_{\alpha}h_{\alpha}$, since $\ell_{\alpha} = S_{\alpha^{-1}}(u_{\alpha^{-1}})^{-1}u_{\alpha}$. This finishes the proof of the theorem. \square

2.1.5. Ribbon Hopf π -coalgebras. Following [48, §11.4], a quasitriangular Hopf π -coalgebra $H = (\{H_{\alpha}\}, \Delta, \varepsilon, S, \varphi, R)$ is said to be *ribbon* if it is endowed with a family $\theta = \{\theta_{\alpha} \in H_{\alpha}\}_{\alpha \in \pi}$ of invertible elements (the *twist*) such that

$$(2.13) \quad \varphi_{\alpha}(x) = \theta_{\alpha}^{-1}x\theta_{\alpha} \text{ for all } \alpha \in \pi \text{ and } x \in H_{\alpha};$$

$$(2.14) \quad S_{\alpha}(\theta_{\alpha}) = \theta_{\alpha^{-1}} \text{ for all } \alpha \in \pi;$$

$$(2.15) \quad \varphi_{\beta}(\theta_{\alpha}) = \theta_{\beta\alpha\beta^{-1}} \text{ for all } \alpha, \beta \in \pi;$$

$$(2.16) \quad \text{for all } \alpha, \beta \in \pi,$$

$$\Delta_{\alpha,\beta}(\theta_{\alpha\beta}) = (\theta_{\alpha} \otimes \theta_{\beta}) \cdot \sigma_{\beta,\alpha}((\varphi_{\alpha^{-1}} \otimes \text{id}_{H_{\alpha}})(R_{\alpha\beta\alpha^{-1},\alpha})) \cdot R_{\alpha,\beta}.$$

Note that θ_1 is a (classical) twist of the quasitriangular Hopf algebra H_1 .

LEMMA 2.8. *Let $H = (\{H_\alpha\}, \Delta, \varepsilon, S, \varphi, R, \theta)$ be a ribbon Hopf π -coalgebra. Then*

- (a) $\varphi_{\alpha^{-1}}(x) = \theta_\alpha x \theta_\alpha^{-1}$ for all $\alpha \in \pi$ and $x \in H_\alpha$;
- (b) $\varepsilon(\theta_1) = 1$;
- (c) If $\alpha \in \pi$ has a finite order d , then θ_α^d is a central element of H_α . In particular θ_1 is central;
- (d) $\theta_\alpha u_\alpha = u_\alpha \theta_\alpha$ for all $\alpha \in \pi$, where the u_α are the Drinfeld elements of H .

Proof. Part (a) is a direct consequence of (2.13), (2.15), and Lemma 2.1. Let us show Part (b). We have

$$\begin{aligned} \theta_1 &= (\varepsilon \otimes \text{id}_{H_1}) \Delta_{1,1}(\theta_1) \quad \text{by (1.2)} \\ &= (\varepsilon \otimes \text{id}_{H_1})((\theta_1 \otimes \theta_1) \cdot \sigma_{1,1}(R_{1,1}) \cdot R_{1,1}) \quad \text{by (2.16) and Lemma 2.1(a)} \\ &= (\varepsilon \otimes \text{id}_{H_1})(\theta_1 \otimes \theta_1) \cdot (\text{id}_{H_1} \otimes \varepsilon)(R_{1,1}) \cdot (\varepsilon \otimes \text{id}_{H_1})(R_{1,1}) \quad \text{by (1.4)} \\ &= \varepsilon(\theta_1) \theta_1 \quad \text{by Lemma 2.4(a)}. \end{aligned}$$

Now $\theta_1 \neq 0$ since it is invertible and $H_1 \neq 0$ (by Corollary 1.2). Hence $\varepsilon(\theta_1) = 1$. To show Part (c), let $\alpha \in \pi$ of finite order d . For any $x \in H_\alpha$, using (2.4), Lemma 2.1 and (2.13), we have that $x = \varphi_1(x) = \varphi_{\alpha^d}(x) = \varphi_\alpha^d(x) = \theta_\alpha^{-d} x \theta_\alpha^d$ and so $\theta_\alpha^d x = x \theta_\alpha^d$. Hence θ_α^d is central in H_α . Finally, let us show Part (d). Using Lemma 2.5(d) and (2.13), we have that $u_\alpha = \varphi_\alpha(u_\alpha) = \theta_\alpha^{-1} u_\alpha \theta_\alpha$, and so $\theta_\alpha u_\alpha = u_\alpha \theta_\alpha$. \square

2.1.5.1. The coopposite Hopf π -coalgebra. Let $H = \{H_\alpha\}_{\alpha \in \pi}$ be a ribbon Hopf π -coalgebra with twist $\theta = \{\theta_\alpha\}_{\alpha \in \pi}$. The coopposite quasitriangular Hopf π -coalgebra H^{cop} (see §2.1.3.1) is ribbon with twist $\theta_\alpha^{\text{cop}} = \theta_{\alpha^{-1}}^{-1}$.

2.1.5.2. The mirror Hopf π -coalgebra. Let $H = \{H_\alpha\}_{\alpha \in \pi}$ be a ribbon Hopf π -coalgebra with twist $\theta = \{\theta_\alpha\}_{\alpha \in \pi}$. Following [48, §11.6], the mirror quasitriangular Hopf π -coalgebra \overline{H} (see §2.1.3.2) is ribbon with twist $\overline{\theta}_\alpha = \theta_{\alpha^{-1}}^{-1}$.

2.1.6. The spherical π -grouplike element. Let $H = (\{H_\alpha\}, \Delta, \varepsilon, S, \varphi, R, \theta)$ be a ribbon Hopf π -coalgebra. For any $\alpha \in \pi$, we set (see Lemma 2.8(d))

$$G_\alpha = \theta_\alpha u_\alpha = u_\alpha \theta_\alpha \in H_\alpha.$$

LEMMA 2.9. (a) $G = (G_\alpha)_{\alpha \in \pi}$ is a π -grouplike element of H ;

- (b) $\varphi_\beta(G_\alpha) = G_{\beta\alpha\beta^{-1}}$ for all $\alpha, \beta \in \pi$;
- (c) $S_\alpha(G_\alpha) = G_{\alpha^{-1}}^{-1}$ for all $\alpha \in \pi$;
- (d) $\theta_\alpha^{-2} = c_\alpha$ for all $\alpha \in \pi$, where $c_\alpha = S_{\alpha^{-1}}(u_{\alpha^{-1}})u_\alpha = u_\alpha S_{\alpha^{-1}}(u_{\alpha^{-1}})$ as in Lemma 2.5(e);
- (e) $S_\alpha(u_\alpha) = G_{\alpha^{-1}}^{-1} u_{\alpha^{-1}} G_{\alpha^{-1}}^{-1}$ for all $\alpha \in \pi$;
- (f) $S_{\alpha^{-1}} S_\alpha(x) = G_\alpha x G_\alpha^{-1}$ for all $\alpha \in \pi$ and $x \in H_\alpha$.

The π -grouplike element $G = (G_\alpha)_{\alpha \in \pi}$ of the previous lemma is called the *spherical π -group-like element of H* .

Proof. Let us show Part (a). Firstly $\varepsilon(G_1) = \varepsilon(\theta_1 u_1) = \varepsilon(\theta_1) \varepsilon(u_1) = 1$ by Lemmas 2.5(g) and 2.8(b). Secondly, for any $\alpha, \beta \in \pi$, using (2.16) and Lemma 2.5(f),

$$\begin{aligned} \Delta_{\alpha,\beta}(G_{\alpha\beta}) &= \Delta_{\alpha,\beta}(\theta_{\alpha\beta} u_{\alpha\beta}) \\ &= \Delta_{\alpha,\beta}(\theta_{\alpha\beta}) \cdot \Delta_{\alpha,\beta}(u_{\alpha\beta}) \\ &= (\theta_\alpha \otimes \theta_\beta) \cdot [\sigma_{\beta,\alpha}((\varphi_{\alpha^{-1}} \otimes \text{id}_{H_\alpha})(R_{\alpha\beta\alpha^{-1},\alpha})) \cdot R_{\alpha,\beta}] \end{aligned}$$

$$\begin{aligned} & \cdot [\sigma_{\beta,\alpha}((\varphi_{\alpha^{-1}} \otimes \text{id}_{H_\alpha})(R_{\alpha\beta\alpha^{-1},\alpha})) \cdot R_{\alpha,\beta}]^{-1} \cdot (u_\alpha \otimes u_\beta) \\ & = G_\alpha \otimes G_\beta. \end{aligned}$$

Thus $G = (G_\alpha)_{\alpha \in \pi} \in G(H)$. Part (b) follows directly from Lemma 2.5(d) and (2.15), and Part (c) from the fact that G is a π -grouplike element. By Part (c) and (2.14), $\theta_\alpha^{-2} = u_\alpha G_\alpha^{-1} \theta_\alpha^{-1} = u_\alpha S_{\alpha^{-1}}(G_{\alpha^{-1}}) \theta_\alpha^{-1} = u_\alpha S_{\alpha^{-1}}(\theta_{\alpha^{-1}} u_{\alpha^{-1}}) \theta_\alpha^{-1} = c_\alpha$ and so Part (d) is established. Let us show Part (e). By (2.14) and Part (c), $G_{\alpha^{-1}}^{-1} u_{\alpha^{-1}} = \theta_{\alpha^{-1}}^{-1} = S_\alpha(\theta_\alpha^{-1}) = S_\alpha(G_\alpha^{-1} u_\alpha) = S_\alpha(u_\alpha) S_\alpha(G_\alpha)^{-1} = S_\alpha(u_\alpha) G_{\alpha^{-1}}$. Therefore $S_\alpha(u_\alpha) = G_{\alpha^{-1}}^{-1} u_{\alpha^{-1}} G_{\alpha^{-1}}$. Finally, to show Part (f), let $x \in H_\alpha$. Using Lemmas 2.5(b) and 2.8(a), we have

$$S_{\alpha^{-1}} S_\alpha(x) = u_\alpha \varphi_{\alpha^{-1}}(x) u_\alpha^{-1} = u_\alpha \theta_\alpha x \theta_\alpha^{-1} u_\alpha^{-1} = G_\alpha x G_\alpha^{-1}.$$

This completes the proof of the lemma. \square

In the following corollary of Theorem 2.7, we compute the distinguished π -grouplike by using the spherical π -grouplike element.

COROLLARY 2.10. *Let $H = \{H_\alpha\}_{\alpha \in \pi}$ be a finite type ribbon Hopf π -coalgebra. Let $g = (g_\alpha)_{\alpha \in \pi}$ be the distinguished π -grouplike element of H , $G = (G_\alpha)_{\alpha \in \pi}$ be the spherical π -grouplike element of H , $h = (h_\alpha)_{\alpha \in \pi} \in G(H)$ as in Theorem 2.7, and $\widehat{\varphi}$ as in Corollary 2.2. Then $\widehat{\varphi} g = G^2 h$ in $G(H)$, i.e., $\widehat{\varphi}(\alpha) g_\alpha = G_\alpha^2 h_\alpha$ for all $\alpha \in \pi$.*

Proof. For any $\alpha \in \pi$, $\widehat{\varphi}(\alpha) g_\alpha = S_{\alpha^{-1}}(u_{\alpha^{-1}})^{-1} u_\alpha h_\alpha = \theta_\alpha^2 u_\alpha^2 h_\alpha = G_\alpha^2 h_\alpha$ by Theorem 2.7(b) and Lemma 2.9(d). \square

2.2. Existence of π -traces

In this section, we introduce the notion of a π -trace for a crossed Hopf π -coalgebra and we show the existence of π -traces for a finite type unimodular Hopf π -coalgebra whose crossing φ verifies that $\widehat{\varphi} = 1$. Moreover, we give sufficient conditions for the homomorphism $\widehat{\varphi}$ to be trivial.

2.2.1. Unimodular Hopf π -coalgebras. A Hopf π -coalgebra $H = \{H_\alpha\}_{\alpha \in \pi}$ is said to be *unimodular* if the Hopf algebra H_1 is unimodular (it means that the spaces of left and right integrals for H_1 coincide). If H_1 is finite-dimensional, then H is unimodular if and only if $\nu = \varepsilon$, where ν is the distinguished grouplike element of H_1^* .

If π is finite, then a left (resp. right) integral for the Hopf algebra $\tilde{H} = \bigoplus_{\alpha \in \pi} H_\alpha$ (see §1.1.3.5) must belong to H_1 , and so the spaces of left (resp. right) integrals for \tilde{H} and H_1 coincide. Hence, when π is finite, H is unimodular if and only if \tilde{H} is unimodular.

One can remark that a semisimple finite type Hopf π -coalgebra $H = \{H_\alpha\}_{\alpha \in \pi}$ is unimodular (since the finite-dimensional Hopf algebra H_1 is semisimple and so unimodular). Note that a cosemisimple Hopf π -coalgebra is not necessarily unimodular.

2.2.2. π -traces. Let $H = (\{H_\alpha\}, \Delta, \varepsilon, S, \varphi)$ be a crossed Hopf π -coalgebra. A π -trace for H is a family of \mathbb{k} -linear forms $\text{tr} = (\text{tr}_\alpha)_{\alpha \in \pi} \in \prod_{\alpha \in \pi} H_\alpha^*$ such that, for any $\alpha, \beta \in \pi$ and $x, y \in H_\alpha$,

$$(2.17) \quad \text{tr}_\alpha(xy) = \text{tr}_\alpha(yx);$$

$$(2.18) \quad \text{tr}_{\alpha^{-1}}(S_\alpha(x)) = \text{tr}_\alpha(x);$$

$$(2.19) \quad \text{tr}_{\beta\alpha\beta^{-1}}(\varphi_\beta(x)) = \text{tr}_\alpha(x).$$

This notion is motivated mainly by topological purposes: π -traces are used in Chapter 4 to construct Hennings-like invariants (see [13, 17]) of principal π -bundles over link complements and over 3-manifolds.

Note that tr_1 is a (usual) trace for the Hopf algebra H_1 , invariant under the action φ of π .

In the next lemma, generalizing [13, PROPOSITION 4.2], we give a characterization of the π -traces.

LEMMA 2.11. *Let $H = \{H_\alpha\}_{\alpha \in \pi}$ be a finite type unimodular ribbon Hopf π -coalgebra with crossing φ . Let $\lambda = (\lambda_\alpha)_{\alpha \in \pi}$ be a non-zero right π -integral for H , $G = (G_\alpha)_{\alpha \in \pi}$ be the spherical π -grouplike element of H , and $\widehat{\varphi}$ be as in Corollary 2.2. Let $\text{tr} = (\text{tr}_\alpha)_{\alpha \in \pi} \in \prod_{\alpha \in \pi} H_\alpha^*$. Then tr is a π -trace for H if and only if there exists a family $z = (z_\alpha)_{\alpha \in \pi} \in \prod_{\alpha \in \pi} H_\alpha$ satisfying, for all $\alpha, \beta \in \pi$,*

- (a) $\text{tr}_\alpha(x) = \lambda_\alpha(G_\alpha z_\alpha x)$ for all $x \in H_\alpha$;
- (b) z_α is central in H_α ;
- (c) $S_\alpha(z_\alpha) = \widehat{\varphi}(\alpha)^{-1} z_{\alpha^{-1}}$;
- (d) $\varphi_\beta(z_\alpha) = \widehat{\varphi}(\beta) z_{\beta\alpha\beta^{-1}}$.

Proof. We first show that, for all $\alpha \in \pi$ and $x, y \in H_\alpha$,

$$(2.20) \quad \lambda_\alpha(G_\alpha xy) = \lambda_\alpha(G_\alpha yx),$$

and

$$(2.21) \quad \widehat{\varphi}(\alpha) \lambda_{\alpha^{-1}}(S_\alpha(x)) = \lambda_\alpha(G_\alpha^2 x).$$

Indeed, let ν be the distinguished grouplike element of H_1^* . Since $\nu = \varepsilon$ (H is unimodular), Theorem 1.16(a) gives that $\lambda_\alpha(G_\alpha xy) = \lambda_\alpha(S_{\alpha^{-1}} S_\alpha(y) G_\alpha x)$. Now, by Lemma 2.9(f), $S_{\alpha^{-1}} S_\alpha(y) = G_\alpha y G_\alpha^{-1}$. Thus $\lambda_\alpha(G_\alpha xy) = \lambda_\alpha(G_\alpha yx)$ and (2.20) is proven. Moreover, Corollary 2.10 gives that $\widehat{\varphi}(\alpha) g_\alpha = G_\alpha^2 h_\alpha$, where $g = (g_\alpha)_{\alpha \in \pi}$ is the distinguished π -grouplike element of H and $h_\alpha = (\text{id}_{H_\alpha} \otimes \nu)(R_{\alpha,1})$. Since $\nu = \varepsilon$ and by Lemma 2.4(a), $h_\alpha = (\text{id}_{H_\alpha} \otimes \varepsilon)(R_{\alpha,1}) = 1_\alpha$. Thus $\widehat{\varphi}(\alpha) g_\alpha = G_\alpha^2$. Now $\lambda_{\alpha^{-1}}(S_\alpha(x)) = \lambda_\alpha(g_\alpha x)$ by Theorem 1.16(c). Hence $\widehat{\varphi}(\alpha) \lambda_{\alpha^{-1}}(S_\alpha(x)) = \lambda_\alpha(G_\alpha^2 x)$ and (2.21) is proven.

Let us suppose that there exists $z = (z_\alpha)_{\alpha \in \pi} \in \prod_{\alpha \in \pi} H_\alpha$ verifying Conditions (a)-(d). For any $\alpha, \beta \in \pi$ and $x, y \in H_\alpha$,

$$\begin{aligned} \text{tr}_\alpha(xy) &= \lambda_\alpha(G_\alpha z_\alpha xy) \quad \text{by Condition (a)} \\ &= \lambda_\alpha(G_\alpha y z_\alpha x) \quad \text{by (2.20)} \\ &= \lambda_\alpha(G_\alpha z_\alpha yx) \quad \text{since } z_\alpha \text{ is central} \\ &= \text{tr}_\alpha(yx) \quad \text{by Condition (a),} \end{aligned}$$

$$\begin{aligned} \text{tr}_{\alpha^{-1}}(S_\alpha(x)) &= \lambda_{\alpha^{-1}}(G_{\alpha^{-1}} z_{\alpha^{-1}} S_\alpha(x)) \\ &= \widehat{\varphi}(\alpha) \lambda_{\alpha^{-1}}(S_\alpha(G_\alpha^{-1} S_\alpha(z_\alpha) S_\alpha(x))) \quad \text{by Condition (c) and Lemma 2.9(c)} \\ &= \widehat{\varphi}(\alpha) \lambda_{\alpha^{-1}}(S_\alpha(x z_\alpha G_\alpha^{-1})) \quad \text{by Lemma 1.1(a)} \\ &= \lambda_\alpha(G_\alpha^2 x z_\alpha G_\alpha^{-1}) \quad \text{by (2.21)} \\ &= \lambda_\alpha(G_\alpha z_\alpha G_\alpha x G_\alpha^{-1}) \quad \text{since } z_\alpha \text{ is central} \\ &= \text{tr}_\alpha(G_\alpha x G_\alpha^{-1}) \\ &= \text{tr}_\alpha(x) \quad \text{since } \text{tr}_\alpha \text{ is symmetric,} \end{aligned}$$

and

$$\begin{aligned} \text{tr}_{\beta\alpha\beta^{-1}}(\varphi_\beta(x)) &= \lambda_{\beta\alpha\beta^{-1}}(G_{\beta\alpha\beta^{-1}} z_{\beta\alpha\beta^{-1}} \varphi_\beta(x)) \\ &= \widehat{\varphi}(\beta)^{-1} \lambda_{\beta\alpha\beta^{-1}}(\varphi_\beta(G_\alpha) \varphi_\beta(z_\alpha) \varphi_\beta(x)) \quad \text{by Condition (d) and Lemma 2.9(b)} \\ &= \widehat{\varphi}(\beta)^{-1} \lambda_{\beta\alpha\beta^{-1}}(\varphi_\beta(G_\alpha z_\alpha x)) \\ &= \widehat{\varphi}(\beta)^{-1} \widehat{\varphi}(\beta) \lambda_\alpha(G_\alpha z_\alpha x) \quad \text{by Corollary 2.2} \\ &= \text{tr}_\alpha(x). \end{aligned}$$

Hence tr is a π -trace.

Conversely, suppose that tr is a π -trace. Recall that H_α^* is a right H_α -module for the action defined, for all $f \in H_\alpha^*$ and $a, x \in H_\alpha$, by

$$(f \leftarrow a)(x) = f(ax).$$

By Corollary 1.14(b), (H_α^*, \leftarrow) is free, its rank is 1 (resp. 0) if $H_\alpha \neq 0$ (resp. $H_\alpha = 0$), and λ_α is a basis vector for (H_α^*, \leftarrow) . Thus, for any $\alpha \in \pi$, there exists $w_\alpha \in H_\alpha$ such that $\text{tr}_\alpha = \lambda_\alpha \leftarrow w_\alpha$. Set $z_\alpha = G_\alpha^{-1}w_\alpha$. Let us verify that the family $z = (z_\alpha)_{\alpha \in \pi}$ verify Conditions (a)-(d). By the definition of z_α , Condition (a) is clearly verified. Let $\alpha \in \pi$ and $x \in H_\alpha$. For any $y \in H_\alpha$,

$$\begin{aligned} (\lambda_\alpha \leftarrow G_\alpha z_\alpha x)(y) &= \lambda_\alpha(G_\alpha z_\alpha xy) \\ &= \text{tr}_\alpha(xy) \\ &= \text{tr}_\alpha(yx) \quad \text{by (2.17)} \\ &= \lambda_\alpha(G_\alpha z_\alpha yx) \\ &= \lambda_\alpha(G_\alpha xz_\alpha y) \quad \text{by (2.20)} \\ &= (\lambda_\alpha \leftarrow G_\alpha xz_\alpha)(y). \end{aligned}$$

Therefore $\lambda_\alpha \leftarrow G_\alpha z_\alpha x = \lambda_\alpha \leftarrow G_\alpha xz_\alpha$. Hence $G_\alpha z_\alpha x = G_\alpha xz_\alpha$ (since λ_α is a basis vector for (H_α^*, \leftarrow)) and so $z_\alpha x = xz_\alpha$. Condition (b) is then verified. Let $\alpha \in \pi$. For any $x \in H_\alpha$,

$$\begin{aligned} (\lambda_{\alpha^{-1}} \leftarrow G_{\alpha^{-1}} S_\alpha(z_\alpha))(x) &= \lambda_{\alpha^{-1}}(G_{\alpha^{-1}} S_\alpha(z_\alpha)x) \\ &= \lambda_{\alpha^{-1}}(S_\alpha(S_\alpha^{-1}(x)z_\alpha G_\alpha^{-1})) \quad \text{by Lemmas 1.1(a) and 2.9(c)} \\ &= \widehat{\varphi}(\alpha)^{-1} \lambda_\alpha(G_\alpha^2 S_\alpha^{-1}(x)z_\alpha G_\alpha^{-1}) \quad \text{by (2.21)} \\ &= \widehat{\varphi}(\alpha)^{-1} \lambda_\alpha(G_\alpha z_\alpha S_\alpha^{-1}(x)) \quad \text{by (2.20) and since } z_\alpha \text{ is central} \\ &= \widehat{\varphi}(\alpha)^{-1} \text{tr}_\alpha(S_\alpha^{-1}(x)) \\ &= \widehat{\varphi}(\alpha)^{-1} \text{tr}_{\alpha^{-1}}(x) \quad \text{by (2.18)} \\ &= (\lambda_{\alpha^{-1}} \leftarrow G_{\alpha^{-1}} \widehat{\varphi}(\alpha)^{-1} z_{\alpha^{-1}})(x). \end{aligned}$$

We conclude as above that $S_\alpha(z_\alpha) = \widehat{\varphi}(\alpha)^{-1} z_{\alpha^{-1}}$, and so Condition (c) is satisfied. Finally, let $\alpha, \beta \in \pi$. For any $x \in H_\alpha$,

$$\begin{aligned} (\lambda_\alpha \leftarrow \widehat{\varphi}(\beta) G_\alpha \varphi_{\beta^{-1}}(z_{\beta\alpha\beta^{-1}}))(x) &= \widehat{\varphi}(\beta) \lambda_\alpha(G_\alpha \varphi_{\beta^{-1}}(z_{\beta\alpha\beta^{-1}})x) \\ &= \lambda_{\beta\alpha\beta^{-1}}(\varphi_\beta(G_\alpha \varphi_{\beta^{-1}}(z_{\beta\alpha\beta^{-1}})x)) \quad \text{by Corollary 2.2} \\ &= \lambda_{\beta\alpha\beta^{-1}}(G_{\beta\alpha\beta^{-1}} z_{\beta\alpha\beta^{-1}} \varphi_\beta(x)) \quad \text{by Lemma 2.9(b)} \\ &= \text{tr}_{\beta\alpha\beta^{-1}}(\varphi_\beta(x)) \\ &= \text{tr}_\alpha(x) \quad \text{by (2.19)} \\ &= (\lambda_\alpha \leftarrow G_\alpha z_\alpha)(x). \end{aligned}$$

Thus $G_\alpha z_\alpha = \widehat{\varphi}(\beta) G_\alpha \varphi_{\beta^{-1}}(z_{\beta\alpha\beta^{-1}})$ and so $\varphi_\beta(z_\alpha) = \widehat{\varphi}(\beta) z_{\beta\alpha\beta^{-1}}$. Hence Condition (d) is verified and the lemma is proven. \square

In the setting of Lemma 2.11, constructing a π -trace from a right π -integral $\lambda = (\lambda_\alpha)_{\alpha \in \pi}$ reduces to finding a family $z = (z_\alpha)_{\alpha \in \pi}$ which satisfies Conditions (b)-(d) of Lemma 2.11. Let us give two possible choices of the family z .

Let Λ be a left integral for H_1 such that $\lambda_1(\Lambda) = 1$. Set $z_1 = \Lambda$ and $z_\alpha = 0$ if $\alpha \neq 1$. This family $z = (z_\alpha)_{\alpha \in \pi}$ verifies Conditions (b)-(d) since H is unimodular (and so Λ is central and $S_1(\Lambda) = \Lambda$) and by Lemma 2.3(a). The π -trace obtained is given by $\text{tr}_1 = \varepsilon$ and $\text{tr}_\alpha = 0$ if $\alpha \neq 1$.

If the homomorphism $\widehat{\varphi}$ of Corollary 2.2 is trivial (that is, $\widehat{\varphi}(\alpha) = 1$ for all $\alpha \in \pi$), then another possible choice is $z_\alpha = 1_\alpha$. In the two next lemmas, we give sufficient conditions for the homomorphism $\widehat{\varphi}$ to be trivial.

LEMMA 2.12. *Let $H = \{H_\alpha\}_{\alpha \in \pi}$ be a finite type crossed Hopf π -coalgebra with crossing φ . If H is semisimple or cosemisimple or if $\varphi_\beta|_{H_1} = \text{id}_{H_1}$ for all $\beta \in \pi$, then $\widehat{\varphi} = 1$.*

Proof. Let $\beta \in \pi$. If H is semisimple, then H_1 is semisimple and thus there exists a left integral Λ for H_1 such that $\varepsilon(\Lambda) = 1$ (by [45, THEOREM 5.1.8]). Now $\varphi_\beta(\Lambda) = \widehat{\varphi}(\beta)\Lambda$ by Lemma 2.3(a). Therefore, using (2.3), $\widehat{\varphi}(\beta) = \widehat{\varphi}(\beta)\varepsilon(\Lambda) = \varepsilon(\widehat{\varphi}(\beta)\Lambda) = \varepsilon\varphi_\beta(\Lambda) = \varepsilon(\Lambda) = 1$. Suppose now that H is cosemisimple. By Theorem 1.24, there exists a right π -integral $\lambda = (\lambda_\alpha)_{\alpha \in \pi}$ for H such that $\lambda_1(1_1) = 1$. Then $\widehat{\varphi}(\beta) = \widehat{\varphi}(\beta)\lambda_1(1_1) = \lambda_1(\varphi_\beta(1_1)) = \lambda_1(1_1) = 1$. Suppose finally that $\varphi_\beta|_{H_1} = \text{id}_{H_1}$. Let $\lambda = (\lambda_\alpha)_{\alpha \in \pi}$ be a non-zero right π -integral for H . Then $\widehat{\varphi}(\beta)\lambda_1 = \lambda_1\varphi_\beta|_{H_1} = \lambda_1$ and thus $\widehat{\varphi}(\beta) = 1$ (since $\lambda_1 \neq 0$ by Lemma 1.9). \square

LEMMA 2.13. *Let $H = \{H_\alpha\}_{\alpha \in \pi}$ be a finite type ribbon Hopf π -coalgebra with crossing φ and twist $\theta = \{\theta_\alpha\}_{\alpha \in \pi}$. Let $\lambda = (\lambda_\alpha)_{\alpha \in \pi}$ be a right π -integral for H . If $\lambda_1(\theta_1) \neq 0$, then $\widehat{\varphi} = 1$.*

Proof. Let $\beta \in \pi$. By (2.1.5.c) and Corollary 2.2, $\lambda_1(\theta_1) = \lambda_1(\varphi_\beta(\theta_1)) = \widehat{\varphi}(\beta)\lambda_1(\theta_1)$. Therefore $\widehat{\varphi}(\beta) = 1$ since $\lambda_1(\theta_1) \neq 0$. \square

We conclude with the following theorem, which follows directly from Lemma 2.11 (by choosing $z_\alpha = 1_\alpha$ for all $\alpha \in \pi$) and Lemmas 2.12 and 2.13.

THEOREM 2.14. *Let $H = \{H_\alpha\}_{\alpha \in \pi}$ be a finite type unimodular ribbon Hopf π -coalgebra with crossing φ and twist $\theta = \{\theta_\alpha\}_{\alpha \in \pi}$. Let $\lambda = (\lambda_\alpha)_{\alpha \in \pi}$ be a right π -integral for H and $G = (G_\alpha)_{\alpha \in \pi}$ be the spherical π -grouplike element of H . Suppose that at least one of the following conditions is verified:*

- (a) H is semisimple;
- (b) H is cosemisimple;
- (c) $\lambda_1(\theta_1) \neq 0$;
- (d) $\varphi_\beta|_{H_1} = \text{id}_{H_1}$ for all $\beta \in \pi$.

Then $\text{tr} = (\text{tr}_\alpha)_{\alpha \in \pi}$, defined by $\text{tr}_\alpha(x) = \lambda_\alpha(G_\alpha x)$ for all $\alpha \in \pi$ and $x \in H_\alpha$, is a π -trace for H .

2.3. The case π finite: an abstract reformulation

The aim of this section is to give, when π is a finite group, an intrinsic formulation of the main definitions and results concerning Hopf π -coalgebras. Throughout this section, we suppose that π is a finite group.

2.3.1. Central prolongations of $F(\pi)$. Let us recall that the Hopf algebra $F(\pi) = k^\pi$ of functions on π has a basis $(e_\alpha : \pi \rightarrow \mathbb{k})_{\alpha \in \pi}$ defined by $e_\alpha(\beta) = \delta_{\alpha,\beta}$ where $\delta_{\alpha,\alpha} = 1$ and $\delta_{\alpha,\beta} = 0$ if $\alpha \neq \beta$. The structure maps of $F(\pi)$ are given by:

$$e_\alpha e_\beta = \delta_{\alpha,\beta} e_\alpha, \quad 1_{F(\pi)} = \sum_{\alpha \in \pi} e_\alpha, \quad \Delta(e_\alpha) = \sum_{\beta\gamma=\alpha} e_\beta \otimes e_\gamma, \quad \varepsilon(e_\alpha) = \delta_{\alpha,1}, \quad \text{and} \quad S(e_\alpha) = e_{\alpha^{-1}}.$$

By a *central prolongation* of $F(\pi)$ we shall mean a Hopf algebra A endowed with a morphism of Hopf algebras $F(\pi) \rightarrow A$ which sends $F(\pi)$ into the center of A . The morphism $F(\pi) \rightarrow A$ is called the *central map* of A . A central prolongation of $F(\pi)$ whose central map is injective is called a *central injection* of $F(\pi)$.

2.3.2. Hopf π -coalgebras as central prolongations of $F(\pi)$. By Section 1.1.3.5, since π is finite, any Hopf π -coalgebra $H = ((H_\alpha, m_\alpha, 1_\alpha)_{\alpha \in \pi}, \{\Delta_{\alpha, \beta}\}_{\alpha, \beta \in \pi}, \varepsilon, \{S_\alpha\}_{\alpha \in \pi})$ gives rise to a Hopf algebra $\tilde{H} = \bigoplus_{\alpha \in \pi} H_\alpha$ with structure maps given by:

$$\tilde{\Delta}|_{H_\alpha} = \sum_{\beta\gamma=\alpha} \Delta_{\beta, \gamma}, \quad \tilde{\varepsilon}|_{H_\alpha} = \delta_{\alpha, 1} \varepsilon, \quad \tilde{m}|_{H_\alpha \otimes H_\beta} = \delta_{\alpha, \beta} m_\alpha, \quad \tilde{1} = \sum_{\alpha \in \pi} 1_\alpha, \quad \text{and} \quad \tilde{S} = \sum_{\alpha \in \pi} S_\alpha.$$

The \mathbb{k} -linear map $F(\pi) \rightarrow \tilde{H}$ defined by $e_\alpha \mapsto 1_\alpha$ clearly gives rise to a morphism of Hopf algebras which sends $F(\pi)$ into the center of \tilde{H} . Hence \tilde{H} is a central prolongation of $F(\pi)$.

The following lemma, due to Enriquez [9], asserts that the correspondence which assigns to every Hopf π -coalgebra $H = \{H_\alpha\}_{\alpha \in \pi}$ the central prolongation \tilde{H} of $F(\pi)$ is one-to-one:

LEMMA 2.15. *Let π be a finite group.*

- (a) *The set of (equivalence classes of) Hopf π -coalgebras is in one-to-one correspondence with the set of (equivalence classes of) central prolongations of $F(\pi)$;*
- (b) *The set of (equivalence classes of) Hopf π -coalgebras $H = \{H_\alpha\}_{\alpha \in \pi}$ with $H_\alpha \neq 0$ for all $\alpha \in \pi$ is in one-to-one correspondence with the set of (equivalence classes of) central injections of $F(\pi)$.*

Proof. Let $H = \{H_\alpha\}_{\alpha \in \pi}$ be a Hopf π -coalgebra. As remarked above, H gives rise to a Hopf algebra $(\tilde{H}, \tilde{\Delta}, \tilde{\varepsilon}, \tilde{S})$ which is a central prolongation of $F(\pi)$ with central map $F(\pi) \rightarrow \tilde{H}$ given by $e_\alpha \mapsto 1_\alpha$. Suppose that $H_\alpha \neq 0$ for all $\alpha \in \pi$. In particular $1_\alpha \neq 0$ for all $\alpha \in \pi$ and so $(1_\alpha)_{\alpha \in \pi}$ is free (since $\tilde{H} = \bigoplus_{\alpha \in \pi} H_\alpha$). Therefore, if $x = \sum_{\alpha \in \pi} x_\alpha e_\alpha \in \ker(F(\pi) \rightarrow \tilde{H})$, where $x_\alpha \in \mathbb{k}$, then $\sum_{\alpha \in \pi} x_\alpha 1_\alpha = 0$ and so $x_\alpha = 0$ for all $\alpha \in \pi$, that is, $x = 0$. Hence $F(\pi) \rightarrow \tilde{H}$ is injective and \tilde{H} is a central injection of $F(\pi)$.

Conversely, let A be a central prolongation of $F(\pi)$. We still denote by $e_\alpha \in A$ the image of $e_\alpha \in F(\pi)$ under the central map $F(\pi) \rightarrow A$ of A . Set $H_\alpha = Ae_\alpha$ for any $\alpha \in \pi$. Since $F(\pi) \rightarrow A$ is a morphism of Hopf algebras and each $e_\alpha \in A$ is central, we have that the family $\{H_\alpha\}_{\alpha \in \pi}$ is a Hopf π -coalgebra with structure maps given by

$$m_\alpha = e_\alpha \cdot m|_{H_\alpha \otimes H_\alpha}, \quad 1_\alpha = e_\alpha, \quad \Delta_{\alpha, \beta} = (e_\alpha \otimes e_\beta) \cdot \Delta|_{H_{\alpha\beta}}, \quad \varepsilon = \varepsilon|_{H_1}, \quad \text{and} \quad S_\alpha = e_{\alpha^{-1}} \cdot S|_{H_\alpha}.$$

Furthermore we have that $\tilde{H} = A$ as a central prolongation of $F(\pi)$, where $\tilde{H} = \bigoplus_{\alpha \in \pi} H_\alpha$ is the central prolongation of $F(\pi)$ associated to $\{H_\alpha\}_{\alpha \in \pi}$ as above. Finally, if the central map $F(\pi) \rightarrow A$ of A is injective, then $e_\alpha \neq 0$ in A and so $H_\alpha = Ae_\alpha \neq 0$ for all $\alpha \in \pi$. \square

Using the correspondence of Lemma 2.15, let us translate the main definitions and results concerning Hopf π -coalgebras (with π finite) into the language of central prolongations of $F(\pi)$.

2.3.3. Crossed central prolongations of $F(\pi)$. Let $(A, \Delta, \varepsilon, S)$ be a central prolongation of $F(\pi)$. We still denote by $e_\alpha \in A$ the image of $e_\alpha \in F(\pi)$ under the central map $F(\pi) \rightarrow A$ of A . Let $\text{Aut}_{\text{Hopf}}(A)$ be the group of Hopf automorphisms of the Hopf algebra A . The central prolongation A of $F(\pi)$ is said to be *crossed* if it is endowed with a group homomorphism $\varphi : \pi \rightarrow \text{Aut}_{\text{Hopf}}(A)$ (the *crossing*) such that $\varphi_\beta(e_\alpha) = e_{\beta\alpha\beta^{-1}}$ for all $\alpha, \beta \in \pi$.

If A is a crossed central prolongation of $F(\pi)$ with crossing φ , then the map $\tilde{\varphi} : A \rightarrow A$ defined by

$$x \in A \mapsto \tilde{\varphi}(x) = \sum_{\alpha \in \pi} \varphi_\alpha(x) e_\alpha \in A$$

is an isomorphism of algebras. Remark that $\tilde{\varphi} S \tilde{\varphi} = S$.

A crossed central prolongation A of $F(\pi)$ with crossing $\varphi : \pi \rightarrow \text{Aut}_{\text{Hopf}}(A)$ leads to a bialgebra A^φ , called φ -*associated to A* , defined by $A^\varphi = A$ as an algebra and with comultiplication and counit

given, for any $x \in A$, by

$$\Delta^\varphi(x) = \sum_{\alpha \in \pi} \sigma_{A,A}(\varphi_{\alpha^{-1}} \otimes \text{id}_A) \Delta(x) \cdot (e_\alpha \otimes 1_A) \quad \text{and} \quad \varepsilon^\varphi(x) = \varepsilon(x).$$

Note that when π is abelian and $\varphi : \pi \rightarrow \text{Aut}_{\text{Hopf}}(A)$ is the trivial morphism, then $A^\varphi = A^{\text{cop}}$.

When the antipode of a crossed central prolongation A of $F(\pi)$ is bijective, then the bialgebra A^φ φ -associated to A is a Hopf algebra with antipode $S^\varphi = \widetilde{\varphi} \circ S^{-1}$. The Hopf algebra A^φ , endowed with the central map of A , is a central prolongation of $F(\pi)$. Furthermore, the homomorphism $\varphi : \pi \rightarrow \text{Aut}_{\text{Hopf}}(A)$ is also a homomorphism $\pi \rightarrow \text{Aut}_{\text{Hopf}}(A^\varphi)$ and defines a crossing for A^φ . Note that we have $(A^\varphi)^\varphi = A$ as a crossed central prolongation of $F(\pi)$.

By Corollary 2.2 and Lemma 2.3, a morphism $\widehat{\varphi} : \pi \rightarrow \mathbb{k}^*$ is associated to the crossing $\varphi : \pi \rightarrow \text{Aut}_{\text{Hopf}}(A)$ of a finite-dimensional crossed central prolongation A of $F(\pi)$ in such a way that, for any $\beta \in \pi$,

- $\lambda \varphi_\beta = \widehat{\varphi}(\beta) \lambda$ for any left or right integral λ for A^* ;
- $\varphi_\beta(\Lambda) = \widehat{\varphi}(\beta) \Lambda$ for any left or right integral Λ for A .

2.3.4. Quasitriangular central prolongations of $F(\pi)$. Let A be a crossed central prolongation of $F(\pi)$ with crossing $\varphi : \pi \rightarrow \text{Aut}_{\text{Hopf}}(A)$. Let $(A^\varphi, \Delta^\varphi, \varepsilon^\varphi)$ be the bialgebra φ -associated to A . The crossed central prolongation A of $F(\pi)$ is said to be *quasitriangular* if it is endowed with an invertible element $R \in A \otimes A$ (the *R-matrix*) such that:

- $R \Delta(x) = \Delta^\varphi(x) R$ for any $x \in A$;
- $(\text{id}_A \otimes \Delta)(R) = R_{13} R_{12}$;
- $(\Delta^\varphi \otimes \text{id}_A)(R) = R_{23} R_{13}$;
- $(\varphi_\beta \otimes \varphi_\beta)(R) = R$ for all $\beta \in \pi$.

Note that when π is abelian and φ is trivial, then R is a usual *R-matrix* for A (since in this case $\Delta^\varphi = \Delta^{\text{cop}}$).

By Lemma 2.5(c), the antipode of a quasitriangular central prolongation A of $F(\pi)$ is bijective. Then the central prolongation A^φ of $F(\pi)$ is quasitriangular with *R-matrix*:

$$R^\varphi = \sigma_{A,A}(\text{id}_A \otimes \widetilde{\varphi})(R).$$

By Lemma 2.4, the *R-matrix* of a quasitriangular central prolongation A of $F(\pi)$ verifies that:

- $(\varepsilon \otimes \text{id}_A)(R) = 1_A = (\text{id}_A \otimes \varepsilon)(R)$;
- $(\widetilde{\varphi} \circ S \otimes \text{id}_A)(R) = R^{-1} = (\text{id}_A \otimes S^{-1})(R)$.

Let A be a quasitriangular central prolongation of $F(\pi)$. We define the *Drinfeld element* of A by:

$$u = m(\widetilde{\varphi} \circ S \otimes \text{id}_A) \sigma_{A,A}(R).$$

By Lemma 2.5, we have that:

- u is invertible and $u^{-1} = m(\text{id}_A \otimes S^2)(R)$;
- $S^2 \circ \widetilde{\varphi}(x) = u x u^{-1}$ for any $x \in A$;
- $\varphi_\beta(u) = u$ for all $\beta \in \pi$;
- $\varepsilon(u) = 1$;
- $\Delta(u) = (R^\varphi R)^{-1}(u \otimes u)$.

By Corollary 2.6, the element $\ell = u S(u)^{-1} = S(u)^{-1} u$ is a grouplike element of A such that $S^2(x) = \ell x \ell^{-1}$ for any $x \in A$. By Theorem 2.7, if A is moreover finite-dimensional, then ℓ is related to the distinguished grouplike element g of A by $e^\varphi g = \ell h$, where e^φ and h are grouplike elements of A defined by $e^\varphi = \sum_{\alpha \in \pi} \widetilde{\varphi}(\alpha) e_\alpha$ and $h = (\text{id}_A \otimes \nu)(R)$. Here ν is the distinguished grouplike element of A^* .

2.3.5. Ribbon central prolongations of $F(\pi)$. A quasitriangular central prolongation (A, φ, R) of $F(\pi)$ is said to be *ribbon* if it is endowed with an invertible element $\theta \in A$ (the *twist*) such that:

- $\widetilde{\varphi}(x) = \theta^{-1}x\theta$ for all $x \in A$;
- $S(\theta) = \theta$;
- $\varphi_\beta(\theta) = \theta$ for all $\beta \in \pi$;
- $\Delta(\theta) = (1_A \otimes \theta)R_{21}(\theta \otimes 1_A)R$.

Note that if π is abelian and φ is trivial, then $\widetilde{\varphi} = \text{id}_A$, that is, θ is central, and so we recover the usual axioms of a twist of A .

If (A, φ, R, θ) is a ribbon central prolongation of $F(\pi)$, then the quasitriangular central prolongation $(A^\varphi, \varphi, R^\varphi)$ φ -associated to A is ribbon with twist $\theta^\varphi = \theta$.

By Lemma 2.9(d), the twist θ of a ribbon central prolongation of $F(\pi)$ verifies that $\theta^{-2} = uS(u)$, where u is the Drinfeld element of A .

The *spherical element* of a ribbon central prolongation A of $F(\pi)$ is $G = \theta u = u\theta$, where u is the Drinfeld element of A . By Lemma 2.9, we have that:

- G is a grouplike element of A ;
- $\varphi_\beta(G) = G$ for all $\beta \in \pi$;
- $S(u) = G^{-1}uG^{-1}$;
- $S^2(x) = GxG^{-1}$ for any $x \in A$.

By Corollary 2.10, the distinguished and spherical grouplike elements of a finite-dimensional ribbon central prolongation of $F(\pi)$ are related by $e^\varphi g = G^2h$, where $e^\varphi = \sum_{\alpha \in \pi} \widehat{\varphi}(\alpha)e_\alpha$ and $h = (\text{id}_A \otimes \nu)(R)$.

Let A be a finite-dimensional ribbon central prolongation of $F(\pi)$ which is unimodular (that is, the Hopf algebra A is unimodular). We suppose that the morphism $\widehat{\varphi} : \pi \rightarrow \mathbb{k}^*$ is trivial (this is the case for example when A is semisimple or cosemisimple or when $\widehat{\varphi} = \text{id}_A$). Let λ be a right integral for A^* . Then, by Lemma 2.11 and Theorem 2.14, the \mathbb{k} -form $\text{tr} : A \rightarrow \mathbb{k}$ defined by $\text{tr}(x) = \lambda(Gx)$ for all $x \in A$ is a trace for A which is φ -invariant, i.e., such that $\text{tr}(\varphi_\beta(x)) = \text{tr}(x)$ for any $\beta \in \pi$ and $x \in A$.

2.4. Examples

In this section, we give some examples of Hopf π -coalgebras. They will be used in Chapter 4 and 5 to explicitly compute some topological invariants.

EXAMPLE 2.16. As remarked in [48], a crossed Hopf group-coalgebra $H^\varphi = \{H_\alpha^\varphi\}_{\alpha \in \pi}$ can be derived from a (classical) Hopf algebra (H, Δ, ϵ, S) and an action $\varphi : \pi \rightarrow \text{Aut}_{\text{Hopf}}(H)$ of π on H by Hopf algebra automorphisms by setting $H_\alpha^\varphi = H$ (as an algebra), $\Delta_{\alpha, \beta} = \Delta$, $\epsilon = \epsilon$, $S_\alpha = S$, and $\varphi_\beta = \varphi(\beta)$ for any $\alpha, \beta \in \pi$.

When π is a subgroup of the group of grouplike elements of H , then π acts on H by conjugacy. In this case, the Hopf π -coalgebra obtained is denoted by $H^\pi = \{H_\alpha^\pi\}_{\alpha \in \pi}$. Furthermore, if H is quasitriangular (resp. ribbon) with R -matrix $R \in H \otimes H$ (resp. twist $\nu \in H$), then H^π is quasitriangular (resp. ribbon) by setting $R_{\alpha, \beta}^\pi = (1_H \otimes \alpha^{-1})R$ (resp. $\theta_\alpha^\pi = \nu\alpha^{-1}$).

EXAMPLE 2.17. Let π be a group and $c : \pi \times \pi \rightarrow \mathbb{k}^*$ be a bicharacter of π , that is, verifying $c(\alpha, \beta\gamma) = c(\alpha, \beta)c(\alpha, \gamma)$ and $c(\alpha\beta, \gamma) = c(\alpha, \gamma)c(\beta, \gamma)$ for all $\alpha, \beta, \gamma \in \pi$. Then the crossed Hopf π -coalgebra \mathbb{k}^{id} constructed from the (trivial) Hopf algebra \mathbb{k} and the trivial action of π on \mathbb{k} (see Example 2.16) is a ribbon Hopf π -coalgebra with R -matrix and twist given by $R_{\alpha, \beta} = c(\alpha, \beta) 1_{\mathbb{k}} \otimes 1_{\mathbb{k}}$ and $\theta_\alpha = c(\alpha, \alpha)$. This ribbon Hopf π -coalgebra is denoted by \mathbb{k}^c . The Drinfeld elements of \mathbb{k}^c are $u_\alpha = c(\alpha, \alpha)^{-1}$. Moreover \mathbb{k}^c is finite dimensional and unimodular and $(\text{id}_{\mathbb{k}})_{\alpha \in \pi}$ is a two-sided π -integral and a π -trace for \mathbb{k}^c . This Hopf π -coalgebra is used in Section 4.1.7.

EXAMPLE 2.18. Following [49], we give an example of an involutory Hopf $\mathbb{Z}/2\mathbb{Z}$ -coalgebra $H = \{H_0, H_1\}$ over \mathbb{C} . It corresponds to the Kac-Paljutkin Hopf algebra viewed as a central injection of $F(\mathbb{Z}/2\mathbb{Z})$.

Set $H_0 = \mathbb{C} \oplus \mathbb{C} \oplus \mathbb{C} \oplus \mathbb{C}$ and $H_1 = \text{Mat}_2(\mathbb{C})$ as algebras. Let $\{e_1, e_2, e_3, e_4\}$ be the (standard) basis of H_0 and $\{e_{1,1}, e_{1,2}, e_{2,1}, e_{2,2}\}$ be the (standard) basis of H_1 . The counit $\varepsilon : H_0 \rightarrow \mathbb{C}$ is given by $\varepsilon(e_1) = 1$ and $\varepsilon(e_2) = \varepsilon(e_3) = \varepsilon(e_4) = 0$. The comultiplication is given by

$$\begin{aligned}\Delta_{0,0}(e_1) &= e_1 \otimes e_1 + e_2 \otimes e_2 + e_3 \otimes e_3 + e_4 \otimes e_4 \\ \Delta_{0,0}(e_2) &= e_1 \otimes e_2 + e_2 \otimes e_1 + e_3 \otimes e_4 + e_4 \otimes e_3 \\ \Delta_{0,0}(e_3) &= e_1 \otimes e_3 + e_3 \otimes e_1 + e_2 \otimes e_4 + e_4 \otimes e_2 \\ \Delta_{0,0}(e_4) &= e_1 \otimes e_4 + e_4 \otimes e_1 + e_2 \otimes e_3 + e_3 \otimes e_2\end{aligned}$$

$$\begin{aligned}\Delta_{0,1}(e_{1,1}) &= e_1 \otimes e_{1,1} + e_2 \otimes e_{2,2} + e_3 \otimes e_{1,1} + e_4 \otimes e_{2,2} \\ \Delta_{0,1}(e_{1,2}) &= e_1 \otimes e_{1,2} - i e_2 \otimes e_{2,1} - e_3 \otimes e_{1,2} + i e_4 \otimes e_{2,1} \\ \Delta_{0,1}(e_{2,1}) &= e_1 \otimes e_{2,1} + i e_2 \otimes e_{1,2} - e_3 \otimes e_{2,1} - i e_4 \otimes e_{1,2} \\ \Delta_{0,1}(e_{2,2}) &= e_1 \otimes e_{2,2} + e_2 \otimes e_{1,1} + e_3 \otimes e_{2,2} + e_4 \otimes e_{1,1}\end{aligned}$$

$$\begin{aligned}\Delta_{1,0}(e_{1,1}) &= e_{1,1} \otimes e_1 + e_{2,2} \otimes e_2 + e_{1,1} \otimes e_3 + e_{2,2} \otimes e_4 \\ \Delta_{1,0}(e_{1,2}) &= e_{1,2} \otimes e_1 + i e_{2,1} \otimes e_2 - e_{1,2} \otimes e_3 - i e_{2,1} \otimes e_4 \\ \Delta_{1,0}(e_{2,1}) &= e_{2,1} \otimes e_1 - i e_{1,2} \otimes e_2 - e_{2,1} \otimes e_3 + i e_{1,2} \otimes e_4 \\ \Delta_{1,0}(e_{2,2}) &= e_{2,2} \otimes e_1 + e_{1,1} \otimes e_2 + e_{2,2} \otimes e_3 + e_{1,1} \otimes e_4\end{aligned}$$

$$\begin{aligned}\Delta_{1,1}(e_1) &= \frac{1}{2}(e_{1,1} \otimes e_{1,1} + e_{2,2} \otimes e_{2,2} + e_{1,2} \otimes e_{1,2} + e_{2,1} \otimes e_{2,1}) \\ \Delta_{1,1}(e_2) &= \frac{1}{2}(e_{1,1} \otimes e_{2,2} + e_{2,2} \otimes e_{1,1} + i e_{1,2} \otimes e_{2,1} - i e_{2,1} \otimes e_{1,2}) \\ \Delta_{1,1}(e_3) &= \frac{1}{2}(e_{1,1} \otimes e_{1,1} + e_{2,2} \otimes e_{2,2} - e_{1,2} \otimes e_{1,2} - e_{2,1} \otimes e_{2,1}) \\ \Delta_{1,1}(e_4) &= \frac{1}{2}(e_{1,1} \otimes e_{2,2} + e_{2,2} \otimes e_{1,1} - i e_{1,2} \otimes e_{2,1} + i e_{2,1} \otimes e_{1,2})\end{aligned}$$

The antipode is given by $S_0(e_k) = e_k$ for any $1 \leq k \leq 4$ and $S_1(e_{k,l}) = e_{l,k}$ for any $1 \leq k, l \leq 2$. One can verify that this leads an involutory Hopf $\mathbb{Z}/2\mathbb{Z}$ -coalgebra.

Some numerical computations concerning this Hopf $\mathbb{Z}/2\mathbb{Z}$ -coalgebra (used in Section 5.3) are given in Appendix B.

EXAMPLE 2.19. Recall that, when π is an abelian group, a ribbon Hopf π -coalgebra with trivial crossing is a ribbon π -colored Hopf algebra in the sense of [34]. Following [35], we give an example of a ribbon Hopf $(\frac{1}{N}\mathbb{Z})/\mathbb{Z}$ -coalgebra, where N is a fixed positive integer, which is derived from finite dimensional quotients of $U_q(\mathfrak{sl}_2)$.

Fix an integer $r \geq 2$. Set $t = \exp(\frac{i\pi}{2r})$ and $q = t^2 = \exp(\frac{i\pi}{r})$. For any $x \in \mathbb{R}$, t^x will denote the scalar $\exp(\frac{ix}{2r})$. In particular, $q^x = t^{2x} = \exp(\frac{ix}{r})$. Note that if $x' \equiv x \pmod{4r}$, then $t^{x'} = t^x$.

For each $\alpha \in (\frac{1}{N}\mathbb{Z})/\mathbb{Z}$, let A_α be the associative algebra over \mathbb{C} with generators $a^{\frac{1}{N}}$, e , and f , subject to the following relations:

$$\begin{aligned}a^{\frac{1}{N}}e &= q^{\frac{1}{N}}ea^{\frac{1}{N}}, & a^{\frac{1}{N}}f &= q^{-\frac{1}{N}}fa^{\frac{1}{N}}, & ef - fe &= \frac{a^2 - a^{-2}}{q - q^{-1}}, \\ e^r &= 0, & f^r &= 0, & a^{4r} &= t^{-4r\alpha}.\end{aligned}$$

The family $A = \{A_\alpha\}_{\alpha \in \pi}$ is a Hopf $(\frac{1}{N}\mathbb{Z})/\mathbb{Z}$ -coalgebra by setting:

$$\begin{aligned}\Delta_{\alpha,\beta}(a^{\frac{1}{N}}) &= a^{\frac{1}{N}} \otimes a^{\frac{1}{N}}, & \Delta_{\alpha,\beta}(e) &= e \otimes a^{-1} + a \otimes e, & \Delta_{\alpha,\beta}(f) &= f \otimes a^{-1} + a \otimes f, \\ \epsilon(a) &= 1, & \epsilon(e) &= 0, & \epsilon(f) &= 0, \\ S_\alpha(a^{\frac{1}{N}}) &= a^{-\frac{1}{N}}, & S_\alpha(e) &= -q^{-1}e, & S_\alpha(f) &= -qf.\end{aligned}$$

We endow A with the trivial crossing, that is, $\varphi_\beta|_{A_\alpha} = \text{id}_{A_\alpha}$. The crossed Hopf $(\frac{1}{N}\mathbb{Z})/\mathbb{Z}$ -coalgebra $A = \{A_\alpha\}_{\alpha \in (\frac{1}{N}\mathbb{Z})/\mathbb{Z}}$ is ribbon with R -matrix

$$R_{\alpha,\beta} = \frac{1}{4r} \sum_{n=0}^{r-1} \sum_{k,l \in \mathbb{Z}/4r\mathbb{Z}} \frac{(q - q^{-1})^n}{[n]!} t^{-(l+\alpha)n + (k-\beta)(l+\alpha-n) - n} f^n a^{k-\beta} \otimes e^n a^{-(l+\alpha)}$$

and twist $\theta_\alpha = a^{2(r-1)} u_\alpha^{-1}$, where the u_α are the Drinfeld elements of A . Here $[n] = \frac{q^n - q^{-n}}{q - q^{-1}}$, $[n]! = [n][n-1] \cdots [1]$, and $[0]! = 1$.

Some results concerning this Hopf $(\frac{1}{N}\mathbb{Z})/\mathbb{Z}$ -coalgebra (used in Example 4.13) are established in Appendix A.

CHAPTER 3

Categorical Hopf group-algebras

A Hennings-like invariant τ_H of principal π -bundles over 3-manifolds will be constructed in Chapter 4 from a finite type unimodular ribbon Hopf π -coalgebra $H = \{H_\alpha\}_{\alpha \in \pi}$. In [48], Turaev constructed another invariant \mathcal{T}_C of such bundles from a modular π -category $C = \coprod_{\alpha \in \pi} C_\alpha$. In order to compare them in the case C is the category $\text{Rep}(H)$ of representations of H , one has to relate the algebraic approach to the categorical one. The appropriate notion which allows us to link these two approaches is that of a Hopf π -algebra in a braided category. The aim of the present chapter is to study such objects. In particular we explicitly construct them from coends and we study their categorical integrals.

This chapter is organized as follows. In Section 3.1, we review the basic definitions and properties of π -categories. In Section 3.2, we study the coends in a π -category. In Section 3.3, we introduce the notion of a Hopf π -algebra in a braided category and we construct such categorical Hopf π -algebras from coends. Finally, in Section 3.4, we study the so-constructed categorical Hopf π -algebra and their π -integrals in the particular cases of a π -category of representations or of a finitely semisimple π -category.

3.1. Basic facts on π -categories

In this section, we review the basic definitions and facts on π -categories introduced by Turaev in [48]. For further details, the reader should refer to [48].

3.1.1. π -categories. Let C be a strict monoidal category with unit object $\mathbb{1}$. Note that every monoidal category is equivalent to a strict monoidal category in a canonical way (see, e.g., [22]).

A left duality in C associates to any object $U \in C$ an object $U^* \in C$ and two morphisms $\text{ev}_U : U^* \otimes U \rightarrow \mathbb{1}$ and $\text{coev}_U : \mathbb{1} \rightarrow U \otimes U^*$ such that

$$(3.1) \quad (\text{id}_U \otimes \text{ev}_U)(\text{coev}_U \otimes \text{id}_U) = \text{id}_U;$$

$$(3.2) \quad (\text{ev}_U \otimes \text{id}_{U^*})(\text{id}_{U^*} \otimes \text{coev}_U) = \text{id}_{U^*}.$$

Note that we can (and we always do) impose that $\text{ev}_{\mathbb{1}} = \text{id}_{\mathbb{1}}$ and $\text{coev}_{\mathbb{1}} = \text{id}_{\mathbb{1}}$.

A monoidal category C is said to be \mathbb{k} -linear if the following conditions are satisfied:

$$(3.3) \quad \text{all sets of morphisms } \text{Hom}_C(U, V) \text{ in } C \text{ are } \mathbb{k}\text{-spaces};$$

$$(3.4) \quad \text{both the composition and the tensor product of morphisms are } \mathbb{k}\text{-bilinear}.$$

We say that a \mathbb{k} -linear category C splits as a disjoint union of subcategories $\{C_\alpha\}$ numerated by certain α if:

$$(3.5) \quad \text{each } C_\alpha \text{ is a full subcategory of } C;$$

$$(3.6) \quad \text{each object of } C \text{ belongs to } C_\alpha \text{ for a unique } \alpha;$$

$$(3.7) \quad \text{for } U \in C_\alpha \text{ and } V \in C_\beta \text{ with } \alpha \neq \beta, \text{ then } \text{Hom}_C(U, V) = 0.$$

A π -category over \mathbb{k} is a \mathbb{k} -linear monoidal category with left duality C which splits as a disjoint union of subcategories $\{C_\alpha\}_{\alpha \in \pi}$ such that

$$(3.8) \quad \text{if } U \in C_\alpha \text{ and } V \in C_\beta, \text{ then } U \otimes V \in C_{\alpha\beta};$$

$$(3.9) \quad \text{if } U \in C_\alpha, \text{ then } U^* \in C_{\alpha^{-1}}.$$

We shall write $C = \coprod_{\alpha \in \pi} C_\alpha$ and call the subcategories $\{C_\alpha\}$ of C the *components* of C . The category C_1 corresponding to the neutral element $1 \in \pi$ is called the *neutral component* of C . Conditions (3.8) and (3.9) show that C_1 is closed under tensor product and taking the dual object. Condition (3.8) implies that $\mathbb{1} \in C_1$. Thus C_1 is a \mathbb{k} -linear monoidal category with left duality.

An *automorphism* of a \mathbb{k} -linear monoidal category C with left duality is an invertible \mathbb{k} -linear (on the morphisms) functor $\varphi : C \rightarrow C$ which preserves the tensor product, the unit object, and the duality, that is, for any objects $U, V \in C$ and any morphisms f, g in C ,

$$(3.10) \quad \varphi(\mathbb{1}) = \mathbb{1};$$

$$(3.11) \quad \varphi(U \otimes V) = \varphi(U) \otimes \varphi(V);$$

$$(3.12) \quad \varphi(U^*) = \varphi(U)^*;$$

$$(3.13) \quad \varphi(f \otimes g) = \varphi(f) \otimes \varphi(g);$$

$$(3.14) \quad \varphi(\text{ev}_U) = \text{ev}_{\varphi(U)} \text{ and } \varphi(\text{coev}_U) = \text{coev}_{\varphi(U)}.$$

The group of automorphisms of C is denoted by $\text{Aut}(C)$.

3.1.2. Crossed π -categories. A *crossed π -category* over \mathbb{k} is a π -category C endowed with a group homomorphism $\varphi : \pi \rightarrow \text{Aut}(C)$ such that

$$(3.15) \quad \text{for all } \alpha, \beta \in \pi, \text{ the functor } \varphi_\alpha = \varphi(\alpha) : C \rightarrow C \text{ maps } C_\beta \text{ into } C_{\alpha\beta\alpha^{-1}}.$$

Notation. For any objects $U \in C_\alpha, V, V' \in C_\beta$, and any morphism $f : V \rightarrow V'$ in C , we set

$${}^U V = \varphi_\alpha(V) \in C_{\alpha\beta\alpha^{-1}} \quad \text{and} \quad {}^U f = \varphi_\alpha(f) : {}^U V \rightarrow {}^U V'.$$

In particular, ${}^U U = \varphi_\alpha(U) \in C_\alpha$ for any $U \in C_\alpha$.

Note that for any objects $U, V, W \in C$ and any morphism $f : V \rightarrow V'$ in C , we have the following identities:

$$\begin{aligned} {}^U(V \otimes W) &= {}^U V \otimes {}^U W, & ({}^{U \otimes V})W &= {}^U({}^V W), & {}^U(V^*) &= ({}^U V)^*, \\ \mathbb{1}_V &= {}^U({}^{U^*} V), = {}^{U^*}({}^U V) = V, & {}^U \mathbb{1} &= \mathbb{1}, & {}^U(f' \circ f) &= {}^U f' \circ {}^U f, \\ {}^U(f \otimes g) &= {}^U f \otimes {}^U g, & {}^U(\text{id}_V) &= \text{id}_{{}^U V}, & {}^U(\text{ev}_V) &= \text{ev}_{{}^U V}, \\ {}^U(\text{coev}_V) &= \text{coev}_{{}^U V}, & ({}^{U \otimes V})f &= {}^U({}^V f), & \mathbb{1}_f &= {}^U({}^{U^*} f) = {}^{U^*}({}^U f) = f. \end{aligned}$$

3.1.3. Braided π -categories. A *braided π -category* is a crossed π -category C endowed with a system of invertible morphisms $\{c_{U,V} : U \otimes V \rightarrow {}^U V \otimes U\}_{U,V \in C}$ (the *braiding*) satisfying the following three conditions:

(3.16) for any morphisms $f : U \rightarrow U', g : V \rightarrow V'$ such that U, U' lie in the same component of C , we have

$$c_{U',V'}(f \otimes g) = ({}^U g \otimes f) c_{U,V};$$

(3.17) for any objects $U, V, W \in C$,

$$c_{U \otimes V, W} = (c_{U, {}^V W} \otimes \text{id}_V)(\text{id}_U \otimes c_{V, W}) \quad c_{U, V \otimes W} = (\text{id}_U \otimes c_{U, W})(c_{U, V} \otimes \text{id}_W)$$

(3.18) the action of π on C preserves the braiding, i.e., for any $\alpha \in \pi$ and any objects $V, W \in C$,

$$\varphi_\alpha(c_{V, W}) = c_{\varphi_\alpha(V), \varphi_\alpha(W)}.$$

Note that if in (3.16) the objects U, U' do not lie in the same component of C then both sides of the equality (3.16) are equal to 0 and have the same source $U \otimes V$ but may have different targets.

For $\pi = 1$, we obtain the standard definition of a braided monoidal category.

A braiding in a crossed π -category \mathcal{C} satisfies a version of the Yang-Baxter identity: for any objects $U, V, W \in \mathcal{C}$,

$$(c_{U,V} \otimes \text{id}_W)(\text{id}_U \otimes c_{V,W}) = (\text{id}_U \otimes c_{V,W})(c_{U,V} \otimes \text{id}_W).$$

Applying (3.17) to $U = V = \mathbb{1}$ and $V = W = \mathbb{1}$ and using the invertibility of $c_{U,\mathbb{1}}$ and $c_{\mathbb{1},U}$, we obtain that $c_{U,\mathbb{1}} = c_{\mathbb{1},U} = \text{id}_U$ for any object $U \in \mathcal{C}$.

3.1.4. Ribbon π -categories. A ribbon π -category is a braided π -category \mathcal{C} endowed with a family of invertible morphisms $\{\theta_U : U \rightarrow {}^U U\}_{U \in \mathcal{C}}$ (the *twist*) satisfying the following conditions:

(3.19) for any morphism $f : U \rightarrow V$ with U, V lying in the same component of \mathcal{C} ,

$$\theta_V f = ({}^U f) \theta_U;$$

(3.20) for any object $U \in \mathcal{C}$,

$$(\theta_U \otimes \text{id}_{U^*}) \text{coev}_U = (\text{id}_{U^*} \otimes \theta_{(U^*)}) \text{coev}_{U^*};$$

(3.21) for any objects $U, V \in \mathcal{C}$,

$$\theta_{U \otimes V} = c_{U \otimes V, U \otimes V} c_{U, V} (\theta_U \otimes \theta_V);$$

(3.22) the action of π on \mathcal{C} preserves the twist, i.e., for any $\alpha \in \pi$ and any object $V \in \mathcal{C}$,

$$\varphi_\alpha(\theta_V) = \theta_{\varphi_\alpha(V)}.$$

It follows from (3.21) that $\theta_{\mathbb{1}} = \text{id}_{\mathbb{1}}$.

For $\pi = 1$, we obtain the standard definition of a ribbon monoidal category.

The neutral component \mathcal{C}_1 of a ribbon π -category \mathcal{C} is a ribbon category in the usual sense of the word.

A ribbon π -category \mathcal{C} canonically has a right duality by associating to any object $U \in \mathcal{C}$ its left dual $U^* \in \mathcal{C}$ and two morphisms $\widetilde{\text{ev}}_U : U \otimes U^* \rightarrow \mathbb{1}$ and $\widetilde{\text{coev}}_U : \mathbb{1} \rightarrow U^* \otimes U$ defined by

$$(3.23) \quad \widetilde{\text{ev}}_U = \text{ev}_{U^*} c_{U, U^*} (\theta_U \otimes \text{id}_{U^*});$$

$$(3.24) \quad \widetilde{\text{coev}}_U = (\text{id}_{U^*} \otimes \theta_U^{-1}) (c_{U^*, U})^{-1} \text{coev}_U.$$

Note that we have $\widetilde{\text{ev}}_{\mathbb{1}} = \text{id}_{\mathbb{1}}$ and $\widetilde{\text{coev}}_{\mathbb{1}} = \text{id}_{\mathbb{1}}$.

3.1.5. Dual morphisms. Axiom (3.20) is better understood when it is rewritten in terms of dual morphisms. For a morphism $f : U \rightarrow V$ in a monoidal category with left duality, the *dual* (or *transpose*) morphism $f^* : V^* \rightarrow U^*$ is defined by

$$(3.25) \quad f^* = (\text{ev}_{V^*} \otimes \text{id}_{U^*}) (\text{id}_{V^*} \otimes f \otimes \text{id}_{U^*}) (\text{id}_{V^*} \otimes \text{coev}_U).$$

It follows from (3.2) that $(\text{id}_U)^* = \text{id}_{U^*}$. It is well-known that $(fg)^* = g^* f^*$ for composable morphisms f, g . Axiom (3.20) can be shown to be equivalent to

$$(\theta_U)^* = \theta_{U^*}.$$

3.1.6. Trace and dimension. Let C be a ribbon π -category. Following [48], the *quantum trace* of an endomorphism $f : U \rightarrow U$ of an object $U \in C$ is defined by

$$(3.26) \quad \mathrm{tr}_q(f) = \tilde{e}v_U(f \otimes \mathrm{id}_{U^*}) \mathrm{coev}_U \in \mathrm{End}_C(\mathbb{1}) = \mathrm{Hom}_C(\mathbb{1}, \mathbb{1}).$$

It is clear that for any $k \in \mathbb{k}$, we have $\mathrm{tr}_q(kf) = k \mathrm{tr}_q(f)$. For any $\beta \in \pi$, we have $\mathrm{tr}_q(\varphi_\beta(f)) = \varphi_\beta(\mathrm{tr}_q(f))$ where on the right hand side φ_β acts on $\mathrm{End}_C(\mathbb{1})$.

For any morphisms $f : U \rightarrow V$, $g : V \rightarrow U$ in C , we have $\mathrm{tr}_q(fg) = \mathrm{tr}_q(gf)$, and for any endomorphisms f, g in C , we have $\mathrm{tr}_q(f^*) = \mathrm{tr}_q(f)$ and $\mathrm{tr}_q(f \otimes g) = \mathrm{tr}_q(f) \mathrm{tr}_q(g)$.

The *quantum dimension* of an object $U \in C$ is defined by

$$(3.27) \quad \dim_q U = \mathrm{tr}_q(\mathrm{id}_U) = \tilde{e}v_U \mathrm{coev}_U \in \mathrm{End}_C(\mathbb{1}).$$

Note that isomorphic objects have equal dimensions and, for any objects U, V and $\beta \in \pi$, we have $\dim_q U^* = \dim_q U$, $\dim_q \varphi_\beta(U) = \varphi_\beta(\dim_q U)$, and $\dim_q(U \otimes V) = \dim_q U \dim_q V$.

For morphisms and objects of the neutral component $C_1 \subset C$, the definitions above coincide with the standard definition of the quantum trace and dimension in a ribbon category. This implies that for any $f \in \mathrm{End}_C(\mathbb{1})$, we have $\mathrm{tr}_q(f) = f$. In particular, $\dim_q \mathbb{1} = \mathrm{tr}_q(\mathrm{id}_{\mathbb{1}}) = \mathrm{id}_{\mathbb{1}}$.

3.1.7. Graphical calculus. Let C be ribbon π -category. Any morphism in C can be graphically represented by a plane diagram. This pictorial calculus will allow us to replace algebraic arguments involving commutative diagrams by simple geometric reasoning.

A morphism $f : V \rightarrow W$ in C is represented by a box with two vertical arrows oriented downwards, as in Figure 3.1(a). Here V, W should be regarded as “colors” of the arrows and f should be regarded as a “color” of the box. More generally, a morphism $f : V_1 \otimes \cdots \otimes V_m \rightarrow W_1 \otimes \cdots \otimes W_n$ may be represented as in Figure 3.1(b).

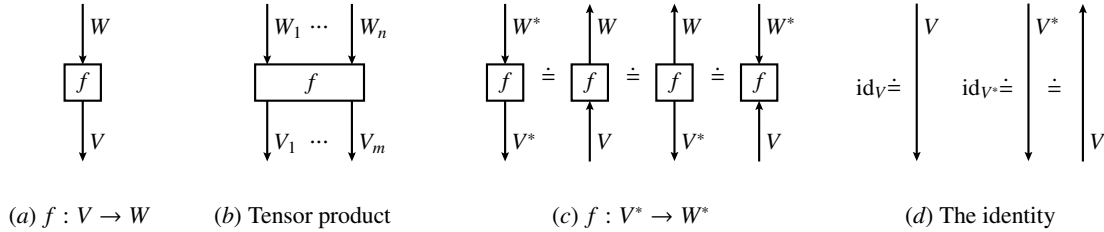

FIGURE 3.1. Plane diagrams of morphisms

We also use vertical arrows oriented upwards under the convention that the morphism sitting in a box attached to such an arrow involves not the color of the arrow but rather the dual object. For example, a morphism $f : V^* \rightarrow W^*$ may be represented in four different ways, see Figure 3.1(c). The symbol “ \doteq ” displayed in the figures denotes equality of the corresponding morphisms in C .

The identity endomorphism of an object $V \in C$ or of its dual V^* will be represented by a vertical arrow as depicted in Figure 3.1(d). Note that a vertical arrow colored with $\mathbb{1}$ may be deleted from any picture without changing the morphism represented by this picture. The empty picture will represent $\mathrm{id}_{\mathbb{1}}$.

The tensor product $f \otimes g$ of two morphisms f and g in C is represented by placing a picture of f to the left of a picture of g . A picture for the composition $g \circ f$ of two (composable) morphisms g and f is obtained by putting a picture of g on the top of a picture of f and by gluing the corresponding free ends of arrows.

The braiding $c_{V,W} : V \otimes W \rightarrow {}^V W \otimes V$ and its inverse $c_{V,W}^{-1} : {}^V W \otimes V \rightarrow V \otimes W$, the twist $\theta_V : V \rightarrow {}^V V$ and its inverse $\theta_V^{-1} : {}^V V \rightarrow V$, and the duality morphisms $\text{ev}_V : V^* \otimes V \rightarrow \mathbb{1}$, $\text{coev}_V : \mathbb{1} \rightarrow V \otimes V^*$, $\bar{\text{ev}}_V : V \otimes V^* \rightarrow \mathbb{1}$, and $\bar{\text{coev}}_V : \mathbb{1} \rightarrow V^* \otimes V$ are represented as in Figures 3.2(a), 3.2(b), and 3.2(c) respectively. The quantum trace of an endomorphism $f : V \rightarrow V$ in \mathcal{C} and the quantum dimension of an object $V \in \mathcal{C}$ may be depicted as in Figure 3.2(d).

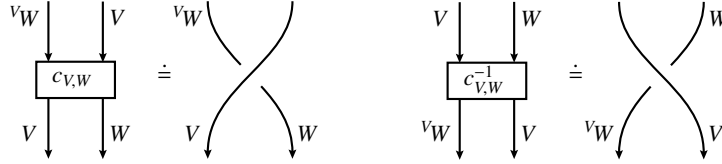

(a) Braiding

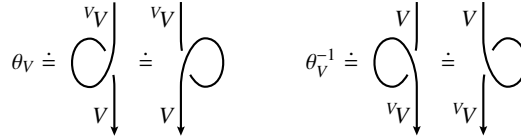

(b) Twist



(c) Duality morphisms



(d) Trace and dimension

FIGURE 3.2.

Note that all the axioms involving the structural morphisms of a ribbon π -category can be traduced in the pictorial language described in this section (see [47] for the case $\pi = 1$). For example, for any objects $U, V \in \mathcal{C}$, we have the graphical equalities of Figure 3.3 which describe Axiom (3.21).

3.1.8. Category of representations of a Hopf π -coalgebra. Let $H = (\{H_\alpha\}, \Delta, \varepsilon, S)$ be a Hopf π -coalgebra. Following [48, § 11.7], a π -category $\text{Rep}(H)$ can be associated to H . Moreover, if H is crossed (resp. quasitriangular, ribbon), then $\text{Rep}(H)$ is crossed (resp. braided, ribbon).

The category $\text{Rep}(H)$ is the disjoint union of the categories $\{\text{Rep}_\alpha(H)\}_{\alpha \in \pi}$, where $\text{Rep}_\alpha(H)$ is the category $\text{Rep}(H_\alpha)$ of finite-dimensional left H_α -modules and of H_α -linear homomorphisms. The tensor product and the unit object in $\text{Rep}(H)$ are defined in the usual way using the comultiplication Δ and the counit ε . For any $U \in \text{Rep}_\alpha(H)$, we have $U^* = \text{Hom}_{\mathbb{k}}(U, \mathbb{k}) \in \text{Rep}_{\alpha^{-1}}(H)$,

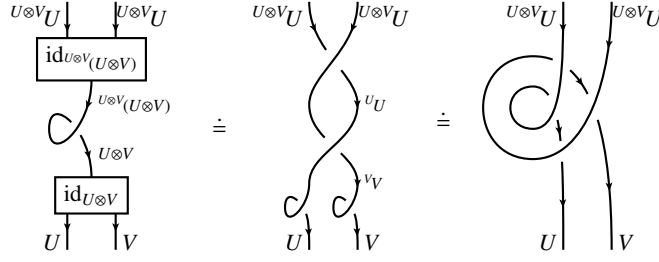

FIGURE 3.3.

where $a \in H_{\alpha^{-1}}$ acts as the transpose of $x \in U \mapsto S_{\alpha^{-1}}(a) \cdot x \in U$. The duality morphism $\text{ev}_U : U^* \otimes U \rightarrow \mathbb{1} = \mathbb{k}$ is the evaluation pairing; it gives rise to coev_U in the usual way (cf. [47, CHAPTER XI]). The conditions defining a Hopf π -coalgebra ensure that $\text{Rep}(H)$ is a π -category.

Suppose that H is crossed with crossing φ . Then each $\varphi_\beta : H_\alpha \rightarrow H_{\beta\alpha\beta^{-1}}$ defines an automorphism φ_β of $\text{Rep}(H)$ as follows: if $U \in \text{Rep}_\alpha(H)$, then $\varphi_\beta(U) \in \text{Rep}_{\beta\alpha\beta^{-1}}(H)$ has the same underlying \mathbb{k} -space as U and each $a \in H_{\beta\alpha\beta^{-1}}$ acts as multiplication by $\varphi_{\beta^{-1}}(a) \in H_\alpha$. Every H_α -linear homomorphism $U \rightarrow U'$ is mapped to itself considered as a $H_{\beta\alpha\beta^{-1}}$ -linear homomorphism. It is easy to check that $\text{Rep}(H)$ is a crossed π -category.

When H is quasitriangular, the R -matrix $R = \{R_{\alpha,\beta}\}_{\alpha,\beta \in \pi}$ of H induces a braiding in $\text{Rep}(H)$ as follows: for $U \in \text{Rep}_\alpha(H)$ and $V \in \text{Rep}_\beta(H)$, the braiding $c_{V,W} : V \otimes W \rightarrow {}^V W \otimes V$ is the composition of multiplication by $R_{\alpha,\beta}$, the flip map $V \otimes W \rightarrow W \otimes V$, and the \mathbb{k} -isomorphism $W \otimes V = {}^V W \otimes V$ which comes from the fact that $W = {}^V W$ as \mathbb{k} -spaces. The conditions defining an R -matrix ensure that $\{c_{V,W}\}_{V,W}$ is a braiding in $\text{Rep}(H)$.

If H is ribbon, then the twist $\theta = \{\theta_\alpha\}_{\alpha \in \pi}$ of H induces a twist in $\text{Rep}(H)$ as follows: for any H_α -module V , the morphism $\theta_V : V \rightarrow {}^V V$ is the composition of multiplication by $\theta_\alpha \in H_\alpha$ and the \mathbb{k} -isomorphism $V \rightarrow {}^V V$ which comes from the fact that ${}^V V = V$ as \mathbb{k} -spaces. One easily verifies that $\text{Rep}(H)$ is ribbon.

LEMMA 3.1. *Let $H = \{H_\alpha\}_{\alpha \in \pi}$ be a ribbon Hopf π -coalgebra and $G = (G_\alpha)_{\alpha \in \pi}$ be the spherical π -grouplike element of H . Then, for any $M \in \text{Rep}_\alpha(H)$, $f \in M^*$, and $m \in M$,*

$$\tilde{\text{ev}}_M(m \otimes f) = f(G_\alpha \cdot m).$$

Proof. Let us write $R_{\alpha,\alpha^{-1}} = a_\alpha \otimes b_{\alpha^{-1}}$. Recall that

$$\begin{aligned} u_\alpha &= m_\alpha(S_{\alpha^{-1}}\varphi_\alpha \otimes \text{id}_{H_\alpha})\sigma_{\alpha,\alpha^{-1}}(R_{\alpha,\alpha^{-1}}) \\ &= m_\alpha(S_{\alpha^{-1}} \otimes \varphi_{\alpha^{-1}})\sigma_{\alpha,\alpha^{-1}}(R_{\alpha,\alpha^{-1}}) \quad \text{by Lemma 2.1 and (2.7)} \\ &= S_{\alpha^{-1}}(b_{\alpha^{-1}})\varphi_{\alpha^{-1}}(a_\alpha). \end{aligned}$$

Then

$$\begin{aligned} \tilde{\text{ev}}_M(m \otimes f) &= \text{ev}_{\varphi_\alpha(M)} \circ c_{\varphi_\alpha(M), M^*} \circ (\theta_M \otimes \text{id}_{M^*})(m \otimes f) \\ &= \text{ev}_{\varphi_\alpha(M)}(b_{\alpha^{-1}} \cdot f \otimes \varphi_{\alpha^{-1}}(a_\alpha)\theta_\alpha \cdot m) \\ &= f(S_{\alpha^{-1}}(b_{\alpha^{-1}})\varphi_{\alpha^{-1}}(a_\alpha)\theta_\alpha \cdot m) \\ &= f(u_\alpha \theta_\alpha \cdot m) \\ &= f(G_\alpha \cdot m). \end{aligned}$$

□

We immediately deduce from Lemma 3.1 that, in the category of representations of a ribbon Hopf π -coalgebra $H = \{H_\alpha\}_{\alpha \in \pi}$, we have $\text{tr}_q(f) = \text{Tr}(G_\alpha \cdot f)$ and $\dim_q(M) = \text{Tr}(G_\alpha \cdot \text{id}_M)$ for any $M \in \text{Rep}_\alpha(H)$ and $f \in \text{End}_{H_\alpha}(M)$, where Tr denotes the usual trace of \mathbb{k} -linear endomorphisms.

3.1.9. Finitely semisimple π -categories. Let C be a \mathbb{k} -linear category. An object V of C is said to be *simple* if $\text{End}_C(V) = \mathbb{k} \text{id}_V$. Since we suppose that \mathbb{k} is a field, we have that if V, W are non-isomorphic simple objects of C , then $\text{Hom}_C(V, W) = 0$. It is clear that an object isomorphic or dual to a simple object is itself simple.

An object D of C is a *direct sum* of a finite family $(U_i)_{i \in I}$ of objects of C if there exist, for each $i \in I$, two morphisms $p_i : D \rightarrow U_i$ and $q_i : U_i \rightarrow D$ verifying

$$\text{id}_D = \sum_{i \in I} q_i \circ p_i \quad \text{and} \quad p_i \circ q_j = \begin{cases} \text{id}_{U_i} & \text{if } i = j, \\ 0 & \text{otherwise.} \end{cases}$$

Note that the object D and the morphisms $\{p_i, q_i\}_{i \in I}$ are unique up to an isomorphism in C .

A π -category $C = \coprod_{\alpha \in \pi} C_\alpha$ is said to be *finitely semisimple* if it satisfies:

(3.28) the unit object $\mathbb{1} \in C_1$ is simple;

(3.29) for each $\alpha \in \pi$, the set J_α of the isomorphism classes of simple objects of C_α is finite;

(3.30) for each $\alpha \in \pi$, finite direct sums exist in C_α ;

(3.31) for each $\alpha \in \pi$, every object of C_α is a finite direct sum of simple objects of C_α .

Axiom (3.31) implies that if U, V are objects of C , then $\text{Hom}(U, V)$ is a finite-dimensional \mathbb{k} -space.

A π -category is said to be *premodular* if it is ribbon and finitely semisimple (see [5] for the case $\pi = 1$). Note that the π -category of representations of a finite type semisimple ribbon Hopf π -coalgebra is premodular.

Let C be a premodular π -category. The action of π on C transforms simple objects into simple objects and so Axiom (3.28) and the equality $\varphi_\alpha(\text{id}_{\mathbb{1}}) = \text{id}_{\mathbb{1}}$ imply that any $\alpha \in \pi$ acts in $\text{End}_C(\mathbb{1}) = \mathbb{k}$ as the identity. Therefore the dimension of objects of C is invariant under the action of π : for any $V \in C$ and $\alpha \in \pi$, we have $\dim(\varphi_\alpha(V)) = \varphi_\alpha(\dim(V)) = \dim(V)$.

3.2. Dinatural transformations and coends

In this section, we first recall some basic facts on dinatural transformations and coends. Then we focus on the case of a π -category.

3.2.1. Basic definitions. Recall that to each category C we associate the *opposite category* C^{op} in the following way: the objects of C^{op} are the objects of C and the morphisms of C^{op} are morphisms f^{op} , in one-one correspondence $f \mapsto f^{\text{op}}$ with the morphisms in C . For each morphism $f : U \rightarrow V$ of C , the domain and codomain of the corresponding f^{op} are as in $f^{\text{op}} : V \rightarrow U$ (the direction is reversed). The composite $f^{\text{op}}g^{\text{op}} = (gf)^{\text{op}}$ is defined in C^{op} exactly when the composite gf is defined in C . This makes C^{op} a category.

Let C and \mathcal{B} be two categories. A *dinatural transformation* $d : F \rightrightarrows b$ between a functor $F : C^{\text{op}} \times C \rightarrow \mathcal{B}$ and an object $b \in \mathcal{B}$ is a function d which assigns to each object $c \in C$ a morphism $d_c : F(c, c) \rightarrow b$ of \mathcal{B} , called the *component of d at c* , in such a way that for every morphism $f : c \rightarrow c'$ of C , the diagram of Figure 3.4 is commutative.

A *coend* of the functor F is a pair $\langle a, i : F \rightrightarrows a \rangle$ consisting of an object $a \in \mathcal{B}$ and a dinatural transformation i from F to a which is *universal* among the dinatural transformation from F to a constant, that is, with the property that, to every dinatural transformation $d : F \rightrightarrows b$, there exists a unique morphism $h : a \rightarrow b$ such that, for all object $c \in C$,

$$(3.32) \quad d_c = h \circ i_c.$$

$$\begin{array}{ccc}
F(c', c) & \xrightarrow{F(\text{id}_{c'}, f)} & F(c', c') \\
\downarrow F(f, \text{id}_c) & & \downarrow d_{c'} \\
F(c, c) & \xrightarrow{d_c} & b
\end{array}$$

FIGURE 3.4. Dinatural transformation

By using the factorization property (3.32), it is easy to verify that if $\langle a, i : F \rightrightarrows a \rangle$ and $\langle a', i' : F \rightrightarrows a' \rangle$ are two coends of F , then they are isomorphic in the sense that there exists an isomorphism $I : a \rightarrow a'$ in \mathcal{B} such that $i'_c = I \circ i_c$ for all object $c \in \mathcal{C}$.

3.2.2. Coends and π -categories. Let $\mathcal{C} = \coprod_{\alpha \in \pi} \mathcal{C}_\alpha$ be a ribbon π -category. For any $\alpha \in \pi$, define a functor $F_\alpha : \mathcal{C}_\alpha^{\text{op}} \times \mathcal{C}_\alpha \rightarrow \mathcal{C}_1$ by

$$(3.33) \quad F_\alpha(X, Y) = X^* \otimes Y \quad \text{and} \quad F_\alpha(f, g) = f^* \otimes g$$

for all objects $X \in \mathcal{C}_\alpha^{\text{op}}$, $Y \in \mathcal{C}_\alpha$ and all morphisms f in $\mathcal{C}_\alpha^{\text{op}}$, g in \mathcal{C}_α .

Let us suppose that, for all $\alpha \in \pi$, the functor F_α admits a coend $\langle A_\alpha, i : F_\alpha \rightrightarrows A_\alpha \rangle$ (the omission of a subscript α in the notation of the function i is unambiguous). In this setting, the morphisms $i_X : X^* \otimes X \rightarrow A_\alpha$ will be graphically represented as in Figure 3.5.

$$\begin{array}{ccc}
\begin{array}{c} \downarrow A_\alpha \\ \boxed{i_X} \\ \begin{array}{c} X \uparrow \quad \downarrow X \end{array} \end{array} & \doteq & \begin{array}{c} \downarrow A_\alpha \\ \text{U-shape} \\ \begin{array}{c} X \uparrow \quad \downarrow X \end{array} \end{array}
\end{array}$$

FIGURE 3.5.

LEMMA 3.2. Let $\alpha, \beta \in \pi$ and an object $Z \in \mathcal{C}_1$. Suppose that ξ is a function which assigns to objects $X \in \mathcal{C}_\alpha$, $Y \in \mathcal{C}_\beta$ a morphism $\xi_{X,Y} : X^* \otimes X \otimes Y^* \otimes Y \rightarrow Z$ in \mathcal{C}_1 in such a way that, for any morphisms $f : X \rightarrow X'$ in \mathcal{C}_α and $g : Y \rightarrow Y'$ in \mathcal{C}_β , the diagram of Figure 3.6 is commutative. Then there exists a unique morphism $h : A_\alpha \otimes A_\beta \rightarrow Z$ such that $\xi_{X,Y} = h \circ (i_X \otimes i_Y)$ for all objects $X \in \mathcal{C}_\alpha$ and $Y \in \mathcal{C}_\beta$.

Proof. Let an object $Y \in \mathcal{C}_\beta$. Define a function ζ^Y which assigns to every object $X \in \mathcal{C}_\alpha$ the morphism $\zeta_X^Y : X^* \otimes X \rightarrow Z \otimes Y^* \otimes Y$ defined in Figure 3.7(a), that is,

$$\zeta_X^Y = (\xi_{X,Y} \otimes \text{id}_{Y^* \otimes Y})(\text{id}_{X^* \otimes X \otimes Y^*} \otimes \text{coev}_Y \otimes \text{id}_Y)(\text{id}_{X^* \otimes X} \otimes \overline{\text{coev}}_Y).$$

Using the commutativity of the diagram of Figure 3.6 and the properties of the duality, it is easy to verify that $\zeta^Y : F_\alpha \rightrightarrows Z \otimes Y^* \otimes Y$ is a dinatural transformation. Therefore it factorizes through the coend, i.e., there exists a unique morphism $a_Y : A_\alpha \rightarrow Z \otimes Y^* \otimes Y$ such that $\zeta_X^Y = a_Y \circ i_X$ for all object $X \in \mathcal{C}_\alpha$.

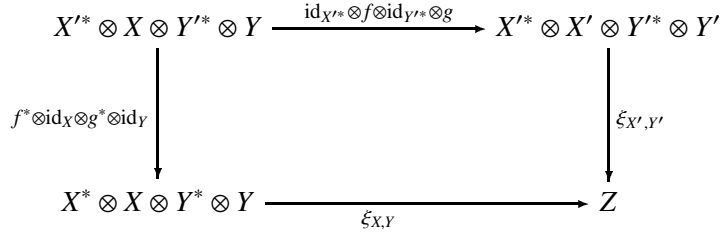

FIGURE 3.6.

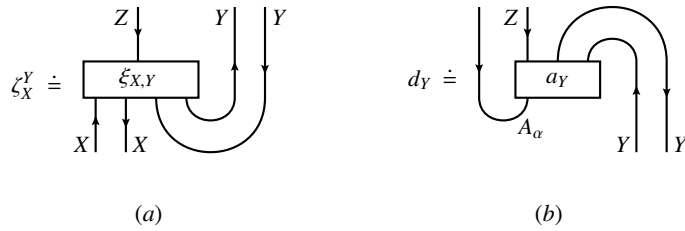

FIGURE 3.7.

Now, for any object $Y \in C_\beta$, define $d_Y : Y^* \otimes Y \rightarrow A_\alpha^* \otimes Z$ as in Figure 3.7(b). We claim that d is a dinatural transformation from F_β to $A_\alpha \otimes Z$. Indeed, if $f : Y \rightarrow Y'$ is a morphism in C_β , then by using the commutativity of the diagram of Figure 3.6, we have the equalities of Figure 3.8.

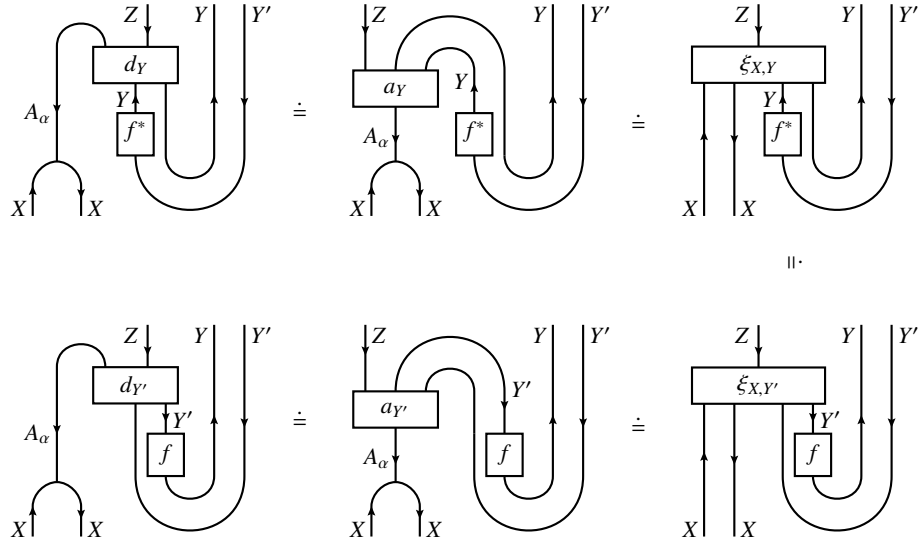

FIGURE 3.8.

Hence, by using the uniqueness of the factorization morphism (via the coend) for the dinatural transformation depicted in Figure 3.9(a), we obtain the equalities described in Figure 3.9(b) and then $d_Y \circ (f^* \otimes \text{id}_Y) = d_{Y'} \circ (\text{id}_{Y'^*} \otimes f)$.

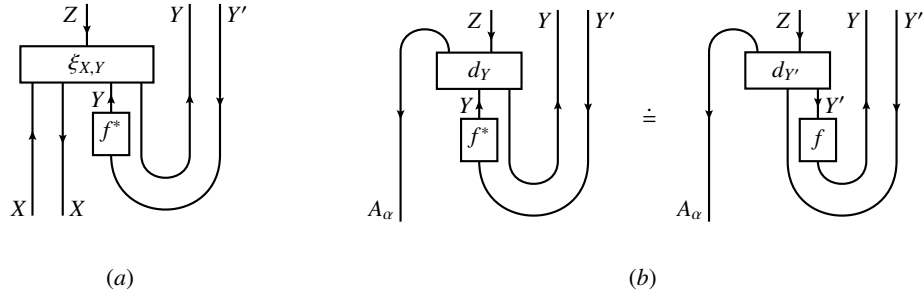

FIGURE 3.9.

Therefore d is a dinatural transformation from F_β to $A_\alpha \otimes Z$ and thus factorizes through a morphism $b : A_\beta \rightarrow A_\alpha^* \otimes Z$ with $d_Y = b \circ i_Y$ for every $Y \in C_\beta$. Set now

$$h = (\widetilde{ev}_{A_\alpha} \otimes id_Z)(id_{A_\alpha} \otimes b) : A_\alpha \otimes A_\beta \rightarrow Z.$$

For any $X \in C_\alpha$ and $Y \in C_\beta$, we have the equalities of Figure 3.10, that is, $\xi_{X,Y} = h \circ (i_X \otimes i_Y)$. Hence the existence part of the lemma is proved.

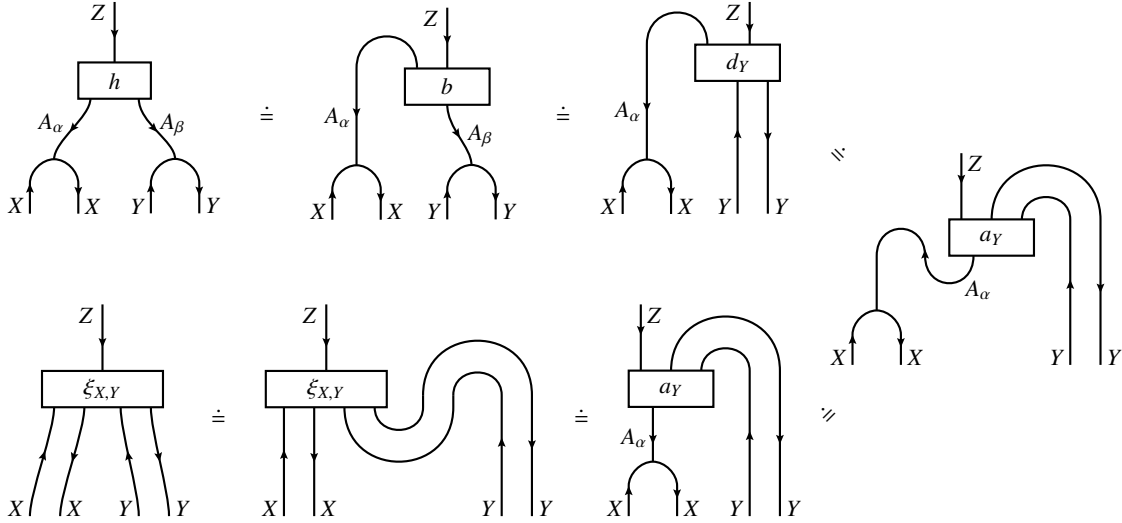

FIGURE 3.10.

To show the uniqueness part, let us suppose that there exists another morphism $h' : A_\alpha \otimes A_\beta \rightarrow Z$ such that $\xi_{X,Y} = h' \circ (i_X \otimes i_Y)$ for all $X \in C_\alpha$ and $Y \in C_\beta$. For any $X \in C_\alpha$ and $Y \in C_\beta$, we have

$$\begin{aligned} \zeta_X^Y &= (\xi_{X,Y} \otimes id_{Y^* \otimes Y})(id_{X^* \otimes X \otimes Y^*} \otimes coev_Y \otimes id_Y)(id_{X^* \otimes X} \otimes \widetilde{coev}_Y) \\ &= (h' \otimes id_{Y^* \otimes Y})(i_X \otimes i_Y \otimes id_{Y^* \otimes Y})(id_{X^* \otimes X \otimes Y^*} \otimes coev_Y \otimes id_Y)(id_{X^* \otimes X} \otimes \widetilde{coev}_Y) \end{aligned}$$

and so, by the uniqueness of the factorization morphism (via the coend),

$$a_Y = (h' \otimes id_{Y^* \otimes Y})(i_{A_\alpha} \otimes i_Y \otimes id_{Y^* \otimes Y})(id_{A_\alpha \otimes Y^*} \otimes coev_Y \otimes id_Y)(id_{A_\alpha} \otimes \widetilde{coev}_Y).$$

Therefore $d_Y = (\text{id}_{A_\alpha^*} \otimes h')(\widetilde{\text{coev}}_{A_\alpha} \otimes i_Y)$ and then, by the uniqueness of the factorization morphism (via the coend), $b = (\text{id}_{A_\alpha^*} \otimes h')(\widetilde{\text{coev}}_{A_\alpha} \otimes \text{id}_{A_\beta})$. Hence

$$h = (\widetilde{\text{ev}}_{A_\alpha} \otimes h')(\text{id}_{A_\alpha} \otimes \widetilde{\text{coev}}_{A_\alpha} \otimes \text{id}_{A_\beta}) = h'.$$

This completes the proof of the lemma. \square

The following corollary can be deduced from Lemma 3.2 by a straightforward induction.

COROLLARY 3.3. *Let n be an integer ≥ 1 , $\alpha_1, \dots, \alpha_n \in \pi$, and an object $Z \in C_1$. Suppose that ξ is a function which assigns to objects $X_1 \in C_{\alpha_1}, \dots, X_n \in C_{\alpha_n}$ a morphism*

$$\xi_{X_1, \dots, X_n} : X_1^* \otimes X_1 \otimes \cdots \otimes X_n^* \otimes X_n \rightarrow Z$$

in C_1 in such a way that, for any morphisms $f_1 \in \text{Hom}_{C_{\alpha_1}}(X_1, X'_1), \dots, f_n \in \text{Hom}_{C_{\alpha_n}}(X_n, X'_n)$, the diagram of Figure 3.11 is commutative. Then there exists a unique morphism

$$h : A_{\alpha_1} \otimes \cdots \otimes A_{\alpha_n} \rightarrow Z$$

such that $\xi_{X_1, \dots, X_n} = h \circ (i_{X_1} \otimes \cdots \otimes i_{X_n})$ for all objects $X_1 \in C_{\alpha_1}, \dots, X_n \in C_{\alpha_n}$.

$$\begin{array}{ccc} X_1^* \otimes X_1 \otimes \cdots \otimes X_n^* \otimes X_n & \xrightarrow{\text{id}_{X_1^*} \otimes f_1 \otimes \cdots \otimes \text{id}_{X_n^*} \otimes f_n} & X_1^* \otimes X'_1 \otimes \cdots \otimes X_n^* \otimes X'_n \\ \downarrow f_1^* \otimes \text{id}_{X_1} \otimes \cdots \otimes f_n^* \otimes \text{id}_{X_n} & & \downarrow \xi_{X'_1, \dots, X'_n} \\ X_1^* \otimes X_1 \otimes \cdots \otimes X_n^* \otimes X_n & \xrightarrow{\xi_{X_1, \dots, X_n}} & Z \end{array}$$

FIGURE 3.11.

3.3. Categorical Hopf π -algebras

In this section, we first introduce the notion of a Hopf π -algebra in a braided category. Then we show that the family of coends of the functors (3.33) leads a categorical Hopf π -algebra.

3.3.1. Hopf π -algebras in a braided category. The notion of a Hopf π -coalgebra is not self-dual. The dual notion is that of a Hopf π -algebra. It is obtained by dualizing the axioms of a Hopf π -coalgebra. In this subsection, we introduce the notion of a categorical Hopf π -algebra.

Let $(\mathcal{B}, \otimes, \mathbb{1})$ be a (usual) braided category with braiding $c = \{c_{U,V} : U \otimes V \rightarrow V \otimes U\}_{U,V \in \mathcal{B}}$. By a *Hopf π -algebra in \mathcal{B}* , we shall mean a family $A = \{A_\alpha\}_{\alpha \in \pi}$ of objects of \mathcal{B} , equipped with the following families of morphisms in \mathcal{B} :

- a multiplication $m = \{m_{\alpha,\beta} : A_\alpha \otimes A_\beta \rightarrow A_{\alpha\beta}\}_{\alpha,\beta \in \pi}$;
- a unit $\eta : \mathbb{1} \rightarrow A_1$;
- a comultiplication $\Delta = \{\Delta_\alpha : A_\alpha \rightarrow A_\alpha \otimes A_\alpha\}_{\alpha \in \pi}$;
- a counit $\varepsilon = \{\varepsilon_\alpha : A_\alpha \rightarrow \mathbb{1}\}_{\alpha \in \pi}$;
- an antipode $S = \{S_\alpha : A_{\alpha^{-1}} \rightarrow A_\alpha\}_{\alpha \in \pi}$;

verifying, for all $\alpha, \beta, \gamma \in \pi$,

$$(3.34) \quad (\Delta_\alpha \otimes \text{id}_{A_\alpha})\Delta_\alpha = (\text{id}_{A_\alpha} \otimes \Delta_\alpha)\Delta_\alpha;$$

$$(3.35) \quad (\varepsilon_\alpha \otimes \text{id}_{A_\alpha}) = \text{id}_{A_\alpha} = (\text{id}_{A_\alpha} \otimes \varepsilon_\alpha)\Delta_\alpha;$$

$$(3.36) \quad m_{\alpha\beta,\gamma}(m_{\alpha,\beta} \otimes \text{id}_{A_\gamma}) = m_{\alpha,\beta\gamma}(\text{id}_{A_\alpha} \otimes m_{\beta,\gamma});$$

$$\begin{aligned}
(3.37) \quad & m_{\alpha,1}(\text{id}_{A_\alpha} \otimes \eta) = \text{id}_{A_\alpha} = m_{1,\alpha}(\eta \otimes \text{id}_{A_\alpha}); \\
(3.38) \quad & \Delta_{\alpha\beta} m_{\alpha,\beta} = (m_{\alpha,\beta} \otimes m_{\alpha,\beta})(\text{id}_{A_\alpha} \otimes c_{A_\alpha, A_\beta} \otimes \text{id}_{A_\beta})(\Delta_\alpha \otimes \Delta_\beta); \\
(3.39) \quad & \Delta_1 \eta = \eta \otimes \eta; \\
(3.40) \quad & \varepsilon_{\alpha\beta} m_{\alpha,\beta} = \varepsilon_\alpha \otimes \varepsilon_\beta; \\
(3.41) \quad & \varepsilon_1 \eta = \text{id}_{\mathbb{1}}; \\
(3.42) \quad & m_{\alpha^{-1},\alpha}(S_{\alpha^{-1}} \otimes \text{id}_{A_\alpha})\Delta_\alpha = \eta \varepsilon_\alpha = m_{\alpha,\alpha^{-1}}(\text{id}_{A_\alpha} \otimes S_{\alpha^{-1}})\Delta_\alpha.
\end{aligned}$$

By dualizing the notion of a π -integral, we get the notion of a categorical π -integral in a categorical π -algebra. By a *right π -integral* for the categorical Hopf π -algebra A , we shall mean a family $\mu = \{\mu_\alpha : \mathbb{1} \rightarrow A_\alpha\}_{\alpha \in \pi}$ of morphisms in \mathcal{B} such that, for all $\alpha, \beta \in \pi$,

$$(3.43) \quad m_{\alpha,\beta}(\mu_\alpha \otimes \text{id}_{A_\beta}) = \mu_{\alpha\beta} \varepsilon_\beta : A_\beta \rightarrow A_{\alpha\beta}.$$

By a *left (resp. right) cointegral* for the categorical Hopf algebra A_1 , we shall mean a morphism $e : A_1 \rightarrow \mathbb{1}$ such that

$$(3.44) \quad (\text{id}_{A_1} \otimes e)\Delta_1 = \eta e : A_1 \rightarrow A_1 \quad (\text{resp. } (e \otimes \text{id}_{A_1})\Delta_1 = \eta e : A_1 \rightarrow A_1).$$

In the next lemma, as in Lemma 1.17, we compute the antipode from a π -integral and a cointegral.

LEMMA 3.4. *Let $\mu = \{\mu_\alpha\}_{\alpha \in \pi}$ be a right π -integral for a categorical Hopf π -algebra $A = \{A_\alpha\}_{\alpha \in \pi}$ in \mathcal{B} . Fix $\alpha \in \pi$.*

(a) *If e is a right cointegral for A_1 , then*

$$e\mu_1 S_\alpha = (e m_{\alpha,\alpha^{-1}} \otimes \text{id}_{A_\alpha})(\text{id}_{A_\alpha} \otimes c_{A_\alpha, A_{\alpha^{-1}}})(\Delta_\alpha \mu_\alpha \otimes \text{id}_{A_{\alpha^{-1}}});$$

(b) *If the antipode is bijective (that is, each S_α is invertible in \mathcal{B}) and e is a left cointegral for A_1 , then*

$$e\mu_1 S_{\alpha^{-1}}^{-1} = (\text{id}_{A_\alpha} \otimes e m_{\alpha,\alpha^{-1}})(\Delta_\alpha \mu_\alpha \otimes \text{id}_{A_{\alpha^{-1}}}).$$

Proof. Let us prove Part (a). Set $f = e\mu_1 m_{\alpha,\alpha^{-1}}(S_\alpha \otimes \text{id}_{A_{\alpha^{-1}}})\Delta_{\alpha^{-1}} : A_{\alpha^{-1}} \rightarrow A_1$. On one hand we have that

$$\begin{aligned}
& m_{1,\alpha}(f \otimes S_\alpha)\Delta_{\alpha^{-1}} \\
&= e\mu_1 m_{1,\alpha}(m_{\alpha,\alpha^{-1}}(S_\alpha \otimes \text{id}_{A_{\alpha^{-1}}})\Delta_{\alpha^{-1}} \otimes S_\alpha)\Delta_{\alpha^{-1}} \\
&= e\mu_1 m_{1,\alpha}(m_{\alpha,\alpha^{-1}} \otimes \text{id}_{A_\alpha})(S_\alpha \otimes \text{id}_{A_{\alpha^{-1}}} \otimes S_\alpha)(\Delta_{\alpha^{-1}} \otimes \text{id}_{A_{\alpha^{-1}}})\Delta_{\alpha^{-1}} \\
&= e\mu_1 m_{\alpha,1}(\text{id}_{A_\alpha} \otimes m_{\alpha^{-1},\alpha})(S_\alpha \otimes \text{id}_{A_{\alpha^{-1}}} \otimes S_\alpha)(\text{id}_{A_{\alpha^{-1}}} \otimes \Delta_{\alpha^{-1}})\Delta_{\alpha^{-1}} \quad \text{by (3.34) and (3.36)} \\
&= e\mu_1 m_{\alpha,1}(S_\alpha \otimes m_{\alpha^{-1},\alpha}(\text{id}_{A_{\alpha^{-1}}} \otimes S_\alpha)\Delta_{\alpha^{-1}})\Delta_{\alpha^{-1}} \\
&= e\mu_1 m_{\alpha,1}(S_\alpha \otimes \eta \varepsilon_{\alpha^{-1}})\Delta_{\alpha^{-1}} \quad \text{by (3.42)} \\
&= e\mu_1 S_\alpha \quad \text{by (3.35) and (3.37)}.
\end{aligned}$$

On the other one, since

$$\begin{aligned}
f &= \eta e\mu_1 \varepsilon_{\alpha^{-1}} \quad \text{by (3.42)} \\
&= (e \otimes \text{id}_{A_1})\Delta_1 m_{\alpha,\alpha^{-1}}(\mu_\alpha \otimes \text{id}_{A_{\alpha^{-1}}}) \quad \text{by (3.43) and (3.44)} \\
&= (e m_{\alpha,\alpha^{-1}} \otimes m_{\alpha,\alpha^{-1}})(\text{id}_{A_\alpha} \otimes c_{A_\alpha, A_{\alpha^{-1}}} \otimes \text{id}_{A_{\alpha^{-1}}})(\Delta_\alpha \mu_\alpha \otimes \Delta_{\alpha^{-1}}) \quad \text{by (3.38)},
\end{aligned}$$

we have that

$$\begin{aligned}
& m_{1,\alpha}(f \otimes S_\alpha)\Delta_{\alpha^{-1}} \\
&= m_{1,\alpha}((e m_{\alpha,\alpha^{-1}} \otimes m_{\alpha,\alpha^{-1}})(\text{id}_{A_\alpha} \otimes c_{A_\alpha, A_{\alpha^{-1}}} \otimes \text{id}_{A_{\alpha^{-1}}})(\Delta_\alpha \mu_\alpha \otimes \Delta_{\alpha^{-1}}) \otimes S_\alpha)\Delta_{\alpha^{-1}} \\
&= (e m_{\alpha,\alpha^{-1}} \otimes m_{1,\alpha}(m_{\alpha,\alpha^{-1}} \otimes \text{id}_{A_\alpha}))(\text{id}_{A_\alpha} \otimes c_{A_\alpha, A_{\alpha^{-1}}} \otimes \text{id}_{A_{\alpha^{-1}}} \otimes S_\alpha)(\Delta_\alpha \mu_\alpha \otimes (\Delta_{\alpha^{-1}} \otimes \text{id}_{A_{\alpha^{-1}}})\Delta_{\alpha^{-1}}) \\
&= (e m_{\alpha,\alpha^{-1}} \otimes m_{\alpha,1}(\text{id}_{A_\alpha} \otimes m_{\alpha^{-1},\alpha}))(\text{id}_{A_\alpha} \otimes c_{A_\alpha, A_{\alpha^{-1}}} \otimes \text{id}_{A_{\alpha^{-1}}} \otimes S_\alpha)(\Delta_\alpha \mu_\alpha \otimes (\text{id}_{A_{\alpha^{-1}}} \otimes \Delta_{\alpha^{-1}})\Delta_{\alpha^{-1}})
\end{aligned}$$

$$\begin{aligned}
& \text{by (3.34) and (3.36)} \\
& = (e m_{\alpha, \alpha^{-1}} \otimes m_{\alpha, 1})(\text{id}_{A_\alpha} \otimes c_{A_\alpha, A_{\alpha^{-1}}})(\Delta_\alpha \mu_\alpha \otimes \text{id}_{A_{\alpha^{-1}}}) \otimes m_{\alpha^{-1}, \alpha}(S_{\alpha^{-1}} \otimes \text{id}_{A_{\alpha^{-1}}}) \Delta_{\alpha^{-1}} \Delta_{\alpha^{-1}} \\
& = (e m_{\alpha, \alpha^{-1}} \otimes m_{\alpha, 1})(\text{id}_{A_\alpha} \otimes c_{A_\alpha, A_{\alpha^{-1}}})(\Delta_\alpha \mu_\alpha \otimes \text{id}_{A_{\alpha^{-1}}}) \otimes \eta \varepsilon_{\alpha^{-1}} \Delta_{\alpha^{-1}} \quad \text{by (3.42)} \\
& = (e m_{\alpha, \alpha^{-1}} \otimes \text{id}_{A_\alpha})(\text{id}_{A_\alpha} \otimes c_{A_\alpha, A_{\alpha^{-1}}})(\Delta_\alpha \mu_\alpha \otimes \text{id}_{A_{\alpha^{-1}}}) \quad \text{by (3.35) and (3.37)}.
\end{aligned}$$

Hence we can conclude that $e \mu_1 S_\alpha = (e m_{\alpha, \alpha^{-1}} \otimes \text{id}_{A_\alpha})(\text{id}_{A_\alpha} \otimes c_{A_\alpha, A_{\alpha^{-1}}})(\Delta_\alpha \mu_\alpha \otimes \text{id}_{A_{\alpha^{-1}}})$.

Let us show Part (b). As in the algebraic case, since the antipode is bijective, we can define a coopposite Hopf π -algebra $A^{\text{cop}} = \{A_\alpha^{\text{cop}}\}_{\alpha \in \pi}$ to A by setting $A_\alpha^{\text{cop}} = A_\alpha$, $m_{\alpha, \beta}^{\text{cop}} = m_{\alpha, \beta}$, $\eta^{\text{cop}} = \eta$, $\Delta_\alpha^{\text{cop}} = c_{A_\alpha, A_\alpha} \Delta_\alpha$, $\varepsilon_\alpha^{\text{cop}} = \varepsilon_\alpha$, and $S_\alpha^{\text{cop}} = S_{\alpha^{-1}}^{-1}$ for any $\alpha, \beta \in \pi$. Since e is a right cointegral for A_1^{cop} and $\mu = \{\mu_\alpha\}_{\alpha \in \pi}$ is a right π -integral for A^{cop} , Part (a) applied to A^{cop} gives

$$e \mu_1 S_\alpha^{\text{cop}} = (e m_{\alpha, \alpha^{-1}}^{\text{cop}} \otimes \text{id}_{A_\alpha^{\text{cop}}})(\text{id}_{A_\alpha^{\text{cop}}} \otimes c_{A_\alpha^{\text{cop}}, A_{\alpha^{-1}}^{\text{cop}}})(\Delta_\alpha^{\text{cop}} \mu_\alpha \otimes \text{id}_{A_{\alpha^{-1}}^{\text{cop}}}),$$

that is,

$$\begin{aligned}
e \mu_1 S_{\alpha^{-1}}^{-1} & = (e m_{\alpha, \alpha^{-1}} \otimes \text{id}_{A_\alpha})(\text{id}_{A_\alpha} \otimes c_{A_\alpha, A_{\alpha^{-1}}})(c_{A_\alpha, A_\alpha} \Delta_\alpha \mu_\alpha \otimes \text{id}_{A_{\alpha^{-1}}}) \\
& = (e m_{\alpha, \alpha^{-1}} \otimes \text{id}_{A_\alpha})(\text{id}_{A_\alpha} \otimes c_{A_\alpha, A_{\alpha^{-1}}})(c_{A_\alpha, A_\alpha} \otimes \text{id}_{A_{\alpha^{-1}}})(\Delta_\alpha \mu_\alpha \otimes \text{id}_{A_{\alpha^{-1}}}) \\
& = (e m_{\alpha, \alpha^{-1}} \otimes \text{id}_{A_\alpha}) c_{A_\alpha, A_\alpha \otimes A_{\alpha^{-1}}}(\Delta_\alpha \mu_\alpha \otimes \text{id}_{A_{\alpha^{-1}}}) \quad \text{by (3.17)} \\
& = c_{A_\alpha, \mathbb{1}}(\text{id}_{A_\alpha} \otimes e m_{\alpha, \alpha^{-1}})(\Delta_\alpha \mu_\alpha \otimes \text{id}_{A_{\alpha^{-1}}}) \quad \text{by (3.16)} \\
& = (\text{id}_{A_\alpha} \otimes e m_{\alpha, \alpha^{-1}})(\Delta_\alpha \mu_\alpha \otimes \text{id}_{A_{\alpha^{-1}}}).
\end{aligned}$$

This completes the proof of the lemma. \square

3.3.2. The coends as a categorical π -algebra. Let $C = \coprod_{\alpha \in \pi} C_\alpha$ be a ribbon π -category. For any $\alpha \in \pi$, let $F_\alpha : C_\alpha^{\text{op}} \times C_\alpha \rightarrow C_1$ be the functor defined as in (3.33).

We suppose that, for every $\alpha \in \pi$, there exists a coend $\langle A_\alpha, i : F_\alpha \rightrightarrows A_\alpha \rangle$ of F_α . Our goal in this section is to show that the family $A = \{A_\alpha\}_{\alpha \in \pi}$ of objects of C_1 admits a structure of a Hopf π -algebra in C_1 .

Let us define the structural morphisms:

- Let $\alpha \in \pi$. For any object $X \in C_\alpha$, set

$$\Delta_X : X^* \otimes X \xrightarrow{\text{id}_{X^*} \otimes \text{coev}_X \otimes \text{id}_X} X^* \otimes X \otimes X^* \otimes X \xrightarrow{i_X \otimes i_X} A_\alpha \otimes A_\alpha,$$

see Figure 3.12. Since $i : F_\alpha \rightrightarrows A_\alpha$ is a dinatural transformation, the function which assigns to objects $X \in C_\alpha$ the morphism Δ_X is a dinatural transformation. Therefore it uniquely factorizes through the coend $\langle A_\alpha, i : F_\alpha \rightrightarrows A_\alpha \rangle$, i.e., there exists a unique morphism $\Delta_\alpha : A_\alpha \rightarrow A_\alpha \otimes A_\alpha$ such that $\Delta_X = \Delta_\alpha \circ i_X$ for all objects $X \in C_\alpha$.

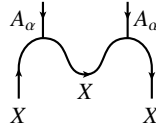

FIGURE 3.12. $\Delta_X : X^* \otimes X \rightarrow A_\alpha \otimes A_\alpha$

- Let $\alpha \in \pi$. The coevaluation $\text{ev}_X : X^* \otimes X \rightarrow \mathbb{1}$ forms a dinatural transformation from F_α to $\mathbb{1}$. Therefore there exists a unique morphism $\varepsilon_\alpha : A_\alpha \rightarrow \mathbb{1}$ such that $\text{ev}_X = \varepsilon_\alpha \circ i_X$ for all objects $X \in C_\alpha$.

- Let $\alpha, \beta \in \pi$. For any objects $X \in C_\alpha$ and $Y \in C_\beta$, let $m_{X,Y} : X^* \otimes X \otimes Y^* \otimes Y \rightarrow A_{\alpha\beta}$ be the morphism of C_1 defined by the diagram of Figure 3.13(a). Since $i : F_{\alpha\beta} \rightrightarrows A_{\alpha\beta}$ is a dinatural transformation and by using the naturality (3.16) of the braiding, the function which assigns to objects $X \in C_\alpha$ and $Y \in C_\beta$ the morphism $m_{X,Y}$ satisfies the hypothesis of Lemma 3.2. Therefore there exists a unique morphism $m_{\alpha,\beta} : A_\alpha \otimes A_\beta \rightarrow A_{\alpha\beta}$ with $m_{X,Y} = m_{\alpha,\beta} \circ (i_X \otimes i_Y)$ for all objects $X \in C_\alpha$ and $Y \in C_\beta$.
- The unit is defined by $\eta : \mathbb{1} = \mathbb{1}^* \otimes \mathbb{1} \xrightarrow{i_{\mathbb{1}}} A_1$.
- Let $\alpha \in \pi$. For any object $X \in C_{\alpha^{-1}}$, let $S_X : X^* \otimes X \rightarrow A_\alpha$ be the morphism of C_1 defined by the diagram of Figure 3.13(b). Since $i : F_\alpha \rightrightarrows A_\alpha$ is a dinatural transformation and by using the naturality of the braiding (3.16) and of the twist (3.19), we have that the function S is a dinatural transformation from $F_{\alpha^{-1}}$ to A_α . Therefore there exists a unique morphism $S_\alpha : A_{\alpha^{-1}} \rightarrow A_\alpha$ such that $S_X = S_\alpha \circ i_X$ for all objects $X \in C_{\alpha^{-1}}$.

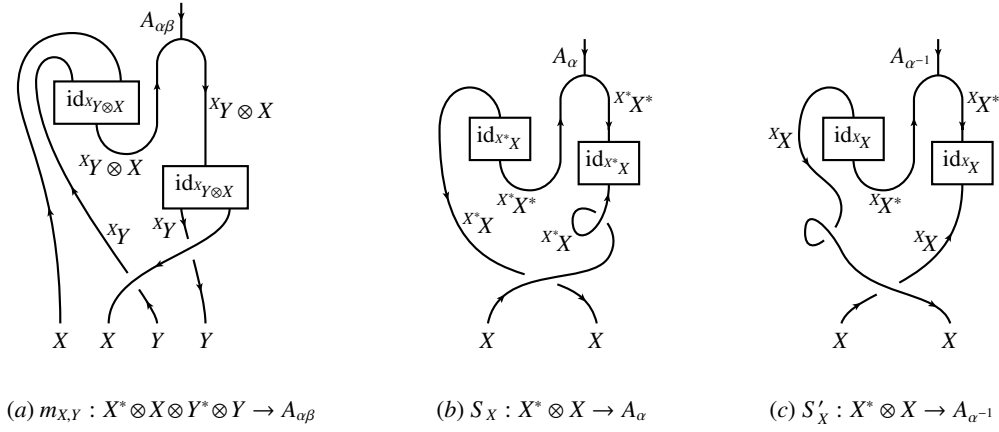

FIGURE 3.13. Structural morphisms of $A = \{A_\alpha\}_{\alpha \in \pi}$

THEOREM 3.5. *Let us consider the family $A = \{A_\alpha\}_{\alpha \in \pi}$ of objects of C_1 , endowed with the comultiplication $\Delta = \{\Delta_\alpha\}_{\alpha \in \pi}$, the counit $\varepsilon = \{\varepsilon_\alpha\}_{\alpha \in \pi}$, the multiplication $m = \{m_{\alpha,\beta}\}_{\alpha,\beta \in \pi}$, the unit $\eta : \mathbb{1} \rightarrow A_1$, and the antipode $S = \{S_\alpha\}_{\alpha \in \pi}$ defined above. Then*

- $A = \{A_\alpha\}_{\alpha \in \pi}$ is a Hopf π -algebra in the category C_1 ;
- Each $S_\alpha : A_{\alpha^{-1}} \rightarrow A_\alpha$ is invertible in C_1 and its inverse $S_\alpha^{-1} : A_\alpha \rightarrow A_{\alpha^{-1}}$ is the factorization morphism (through the coend $\langle A_\alpha, i : F_\alpha \rightrightarrows A_\alpha \rangle$) of the dinatural transformation $S' : F_\alpha \rightrightarrows A_{\alpha^{-1}}$ defined by the diagram of Figure 3.13(c);
- The antipode satisfies $S_{\alpha^{-1}} \circ S_\alpha = \theta_{A_\alpha}$ for all $\alpha \in \pi$.

Note that $(A_1, m_{1,1}, \eta, \Delta_1, \varepsilon_1, S_1)$ is a (usual) Hopf algebra in the category C_1 .

The case $\pi = 1$ was first shown in [30].

Proof. Let us show Part (a). Let $\xi : F_\alpha \rightrightarrows A_\alpha \otimes A_\alpha \otimes A_\alpha$ be the dinatural transformation defined, for any object $X \in C_\alpha$, by

$$\xi_X = (i_X \otimes i_X \otimes i_X)(\text{id}_{X^*} \otimes \text{coev}_X \otimes \text{coev}_X \otimes \text{id}_X) : X^* \otimes X \rightarrow A_\alpha \otimes A_\alpha \otimes A_\alpha.$$

By considering the equalities of morphisms depicted in Figure 3.14, we have that

$$(\text{id}_{A_\alpha} \otimes \Delta_\alpha) \Delta_\alpha i_X = \xi_X = (\Delta_\alpha \otimes \text{id}_{A_\alpha}) \Delta_\alpha i_X.$$

Therefore, by the uniqueness of morphism which factorizes the dinatural transformation ξ through the coend $\langle A_\alpha, i : F_\alpha \rightrightarrows A_\alpha \rangle$, we obtain that Axiom (3.34) is satisfied.

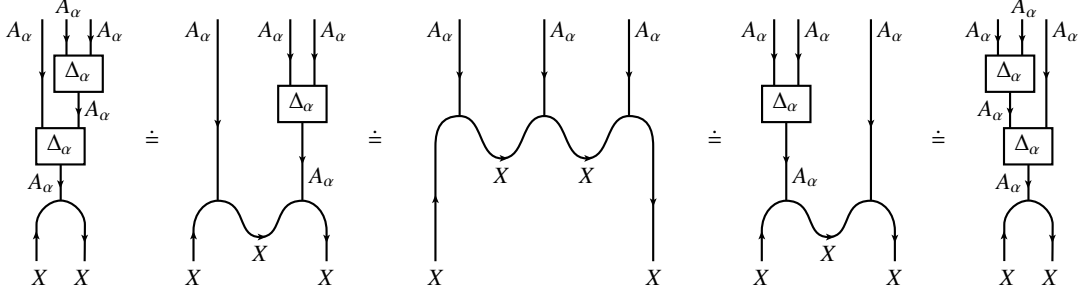

FIGURE 3.14.

Let $\psi : F_\alpha \rightrightarrows A_\alpha$ be the dinatural transformation defined, for any object $X \in C_\alpha$, by

$$\psi_X = (i_X \otimes \text{ev}_X)(\text{id}_{X^*} \otimes \text{coev}_X \otimes \text{id}_X) : X^* \otimes X \rightarrow A_\alpha.$$

Using the rigidity axioms (3.1)-(3.2), we obtain that $\psi_X = i_X = (\text{ev}_X \otimes i_X)(\text{id}_{X^*} \otimes \text{coev}_X \otimes \text{id}_X)$. Therefore

$$\psi_X = (\text{id}_{A_\alpha} \otimes \varepsilon_\alpha)\Delta_\alpha i_X = \text{id}_{A_\alpha} i_X = (\varepsilon_\alpha \otimes \text{id}_{A_\alpha})\Delta_\alpha i_X.$$

and so, by the uniqueness of the factorization of ψ through the coend $\langle A_\alpha, i : F_\alpha \rightrightarrows A_\alpha \rangle$, we obtain that Axiom (3.35) is satisfied.

Recall that the braiding verifies $c_{U,1} = c_{1,U} = \text{id}_U$ for all object $U \in C_\alpha$. Therefore, for any object $X \in C_\alpha$, we have that

$$m_{\alpha,1}(\text{id}_{A_\alpha} \otimes \eta)i_X = m_{X,1}(\text{id}_{X^* \otimes X} \otimes \widetilde{\text{coev}}_1) = i_X = m_{1,X}(\widetilde{\text{coev}}_1 \otimes \text{id}_{X^* \otimes X}) = m_{1,\alpha}(\eta \otimes \text{id}_{A_\alpha})i_X,$$

and so, by the uniqueness of a factorization through a coend, Axiom (3.37) is satisfied.

By using the naturality of the braiding (3.16), the rigidity axioms (3.1)-(3.2), and the uniqueness of the factorization morphism described in Corollary 3.3, Axiom (3.36) can be deduced from the equalities of Figure 3.15, where empty boxes represent the appropriate identity morphism.

By the same reasoning, Axioms (3.38) and (3.40) may be deduced from the equalities depicted in Figures 3.16 and 3.17 respectively.

Since $\text{ev}_1 = \text{id}_1$ and $\widetilde{\text{coev}}_1 = \text{id}_1$, we have that $\Delta_1 \eta = \Delta_1 i_1 = \Delta_1 = \Delta_1(i_1 \otimes i_1) = \Delta_1(\eta \otimes \eta)$ and $\varepsilon_1 \eta = \varepsilon_1 i_1 = \varepsilon_1 = \text{ev}_1 = \text{id}_1$. Therefore Axioms (3.39) and (3.41).

Finally, by using the naturality of the braiding (3.16) and of the twist (3.19), the rigidity axioms (3.1)-(3.2), the definition (3.23) of the right evaluation $\widetilde{\text{ev}}$, and (3.21), we have that Axiom (3.42) is a consequence of the equalities depicted in Figure 3.18, where the symbol " \doteq " means that we use the commutativity property of a dinatural transformation (see the commutative diagram of Figure 3.4). Hence we can conclude that $A = \{A_\alpha\}_{\alpha \in \mathcal{A}}$ is a Hopf π -algebra in the category C_1 .

By using the same arguments, Parts (b) and (c) are verified in Figures 3.19 and 3.20 respectively, where $S'_\alpha : A_{\alpha^{-1}} \rightarrow A_\alpha$ is the morphism in C_1 which factorizes the dinatural transformation $S' : F_\alpha \rightrightarrows A_{\alpha^{-1}}$, depicted in Figure 3.13(c), through the coend $\langle A_\alpha, i : F_\alpha \rightrightarrows A_\alpha \rangle$. \square

3.4. Particular cases

In this section, we study the categorical Hopf π -algebra of Theorem 3.5 and their π -integrals in the cases of a π -category of representations or of a finitely semisimple π -category. We show in

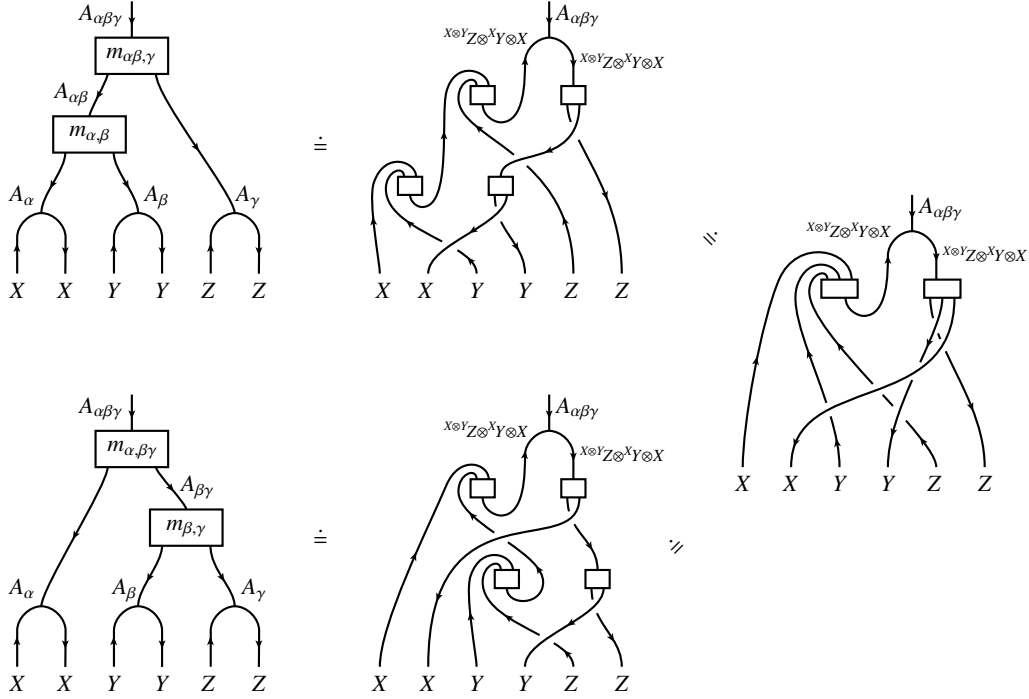

FIGURE 3.15. $m_{\alpha\beta,\gamma}(m_{\alpha,\beta} \otimes \text{id}_{A_\gamma}) = m_{\alpha,\beta\gamma}(\text{id}_{A_\alpha} \otimes m_{\beta,\gamma})$

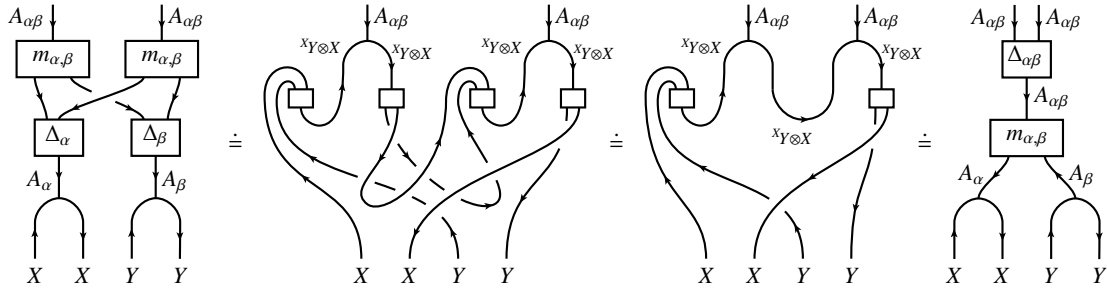

FIGURE 3.16. $(m_{\alpha,\beta} \otimes m_{\alpha,\beta})(\text{id}_{A_\alpha} \otimes c_{A_\alpha, A_\beta} \otimes \text{id}_{A_\beta})(\Delta_\alpha \otimes \Delta_\beta)(i_X \otimes i_Y) = \Delta_{\alpha\beta} m_{\alpha,\beta}(i_X \otimes i_Y)$

particular that for a π -category $\text{Rep}(H)$ of representations of a Hopf π -coalgebra $H = \{H_\alpha\}_{\alpha \in \pi}$, the categorical π -integrals are in one-to-one correspondence with the π -integrals of H .

3.4.1. Coends in a π -category of representations. Let $H = \{H_\alpha\}_{\alpha \in \pi}$ be a finite type Hopf π -coalgebra and $\text{Rep}(H) = \coprod_{\alpha \in \pi} \text{Rep}_\alpha(H)$ be its π -category of representations (see Section 3.1.8). Fix $\alpha \in \pi$. Set

$$(3.45) \quad A_\alpha = H_\alpha^* = \text{Hom}_{\mathbb{k}}(H_\alpha, \mathbb{k}).$$

It is a finite-dimensional left H_1 -module under the action defined, for all $h \in H_1$, $x \in H_\alpha$, and $f \in A_\alpha$, by

$$\langle h \triangleright f, x \rangle = \langle f, S_{\alpha^{-1}}(h_{(1, \alpha^{-1})}) x h_{(2, \alpha)} \rangle,$$

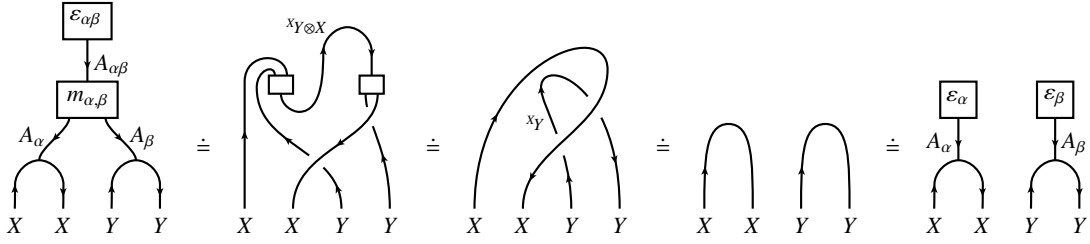

FIGURE 3.17. $\varepsilon_{\alpha\beta} m_{\alpha,\beta}(i_X \otimes i_Y) = (\varepsilon_\alpha \otimes \varepsilon_\beta)(i_X \otimes i_Y)$

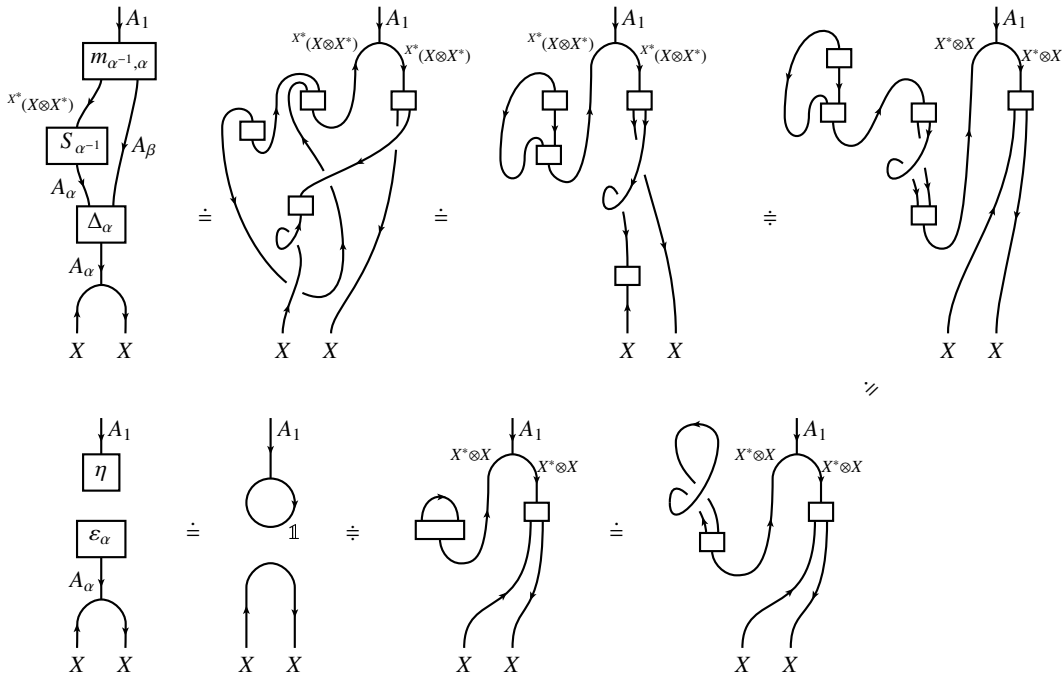

FIGURE 3.18. $m_{\alpha^{-1},\alpha}(S_{\alpha^{-1}} \otimes \text{id}_{A_\alpha}) \Delta_\alpha i_X = \eta \varepsilon_\alpha i_X$

where \langle, \rangle denotes the usual pairing between a \mathbb{k} -space and its dual. Given a module $M \in \text{Rep}_\alpha(H)$, let $i_M : M^* \otimes M \rightarrow A_\alpha$ be the map defined, for all $l \in M^*$, $m \in M$, and $x \in H_\alpha$, by

$$\langle i_M(l \otimes m), x \rangle = \langle l, x \cdot m \rangle,$$

where \cdot denotes the left action of H_α on M .

Let $F_\alpha : \text{Rep}_\alpha(H)^{\text{op}} \times \text{Rep}_\alpha(H) \rightarrow \text{Rep}_1(H)$ be the functor defined as in (3.33).

LEMMA 3.6. *Let $H = \{H_\alpha\}_{\alpha \in \pi}$ be a finite type Hopf π -coalgebra. Then*

- (a) $\langle A_\alpha, i : F_\alpha \rightrightarrows A_\alpha \rangle$ is a coend of F_α .
- (b) If $\xi : F_\alpha \rightrightarrows Z$ is a dinatural transformation from F_α to a module $Z \in \text{Rep}_1(H)$, then the (unique) morphism $r : A_\alpha \rightarrow Z$ such that $\xi_M = r \circ i_M$ for all $M \in \text{Rep}_\alpha(H)$ is given by $f \in A_\alpha = H_\alpha^* \mapsto r(f) = \xi_{H_\alpha}(f \otimes 1_\alpha)$.

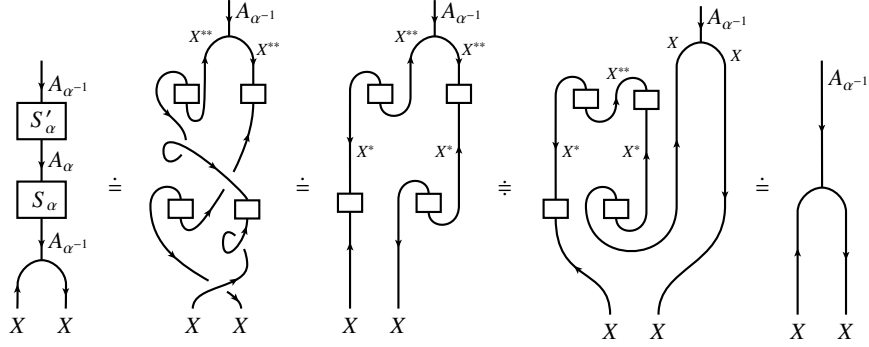
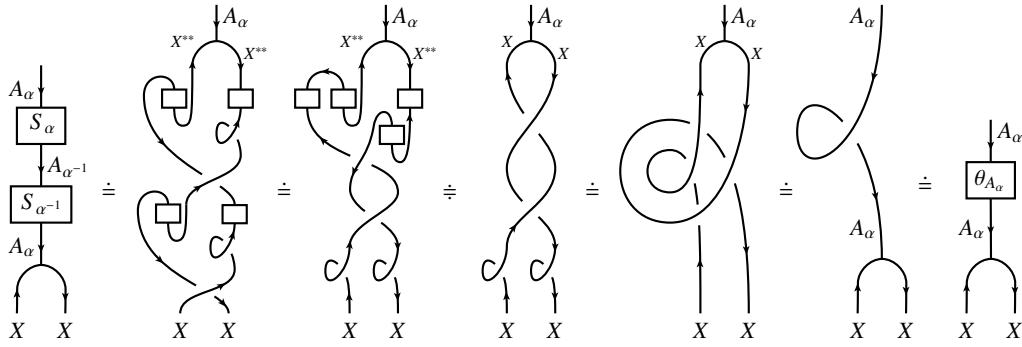
FIGURE 3.19. $S'_\alpha S_\alpha i_X = i_X$ FIGURE 3.20. $S_\alpha S_{\alpha^{-1}} i_X = \theta_{A_\alpha} i_X$

Proof. Firstly, for any module $M \in \text{Rep}_\alpha(H)$, the map i_M is H_1 -linear. Indeed, for all $l \in M^*$, $m \in M$, $x \in H_\alpha$, and $h \in H_1$, we have that

$$\begin{aligned}
 \langle i_M(h \cdot (l \otimes m)), x \rangle &= \langle i_M(h_{(1, \alpha^{-1})} \cdot l \otimes h_{(2, \alpha)} \cdot m), x \rangle \\
 &= \langle h_{(1, \alpha^{-1})} \cdot l, x \cdot (h_{(2, \alpha)} \cdot m) \rangle \\
 &= \langle l, S_{\alpha^{-1}}(h_{(1, \alpha^{-1})}) \cdot (x \cdot (h_{(2, \alpha)} \cdot m)) \rangle \\
 &= \langle l, (S_{\alpha^{-1}}(h_{(1, \alpha^{-1})}) x a_{(2, \alpha)}) \cdot m \rangle \\
 &= \langle h \triangleright i_M(l \otimes m), x \rangle \quad \text{by the definition of the action } \triangleright \text{ of } H_1 \text{ on } A_\alpha.
 \end{aligned}$$

Let us verify that $i : F_\alpha \xrightarrow{\sim} A_\alpha$ is a dinatural transformation. Let $f : M \rightarrow N$ be a H_α -linear morphism in $\text{Rep}_\alpha(H)$ and $l \in N^*$, $m \in M$. Then, for all $x \in H_\alpha$,

$$\begin{aligned}
 \langle i_N(l \otimes f(m)), x \rangle &= \langle l, x \cdot f(m) \rangle \\
 &= \langle l, f(x \cdot m) \rangle \quad \text{since } f \text{ is } H_\alpha\text{-linear} \\
 &= \langle f^*(l), x \cdot m \rangle \\
 &= \langle i_M(f^*(l) \otimes m), x \rangle,
 \end{aligned}$$

that is, $i_N(l \otimes f(m)) = i_M(f^*(l) \otimes m)$. Thus $i : F_\alpha \xrightarrow{\sim} A_\alpha$ is a dinatural transformation.

Let $\xi : F_\alpha \xrightarrow{\sim} Z$ be a dinatural transformation from F_α to a module $Z \in \text{Rep}_1(H)$. We have to verify that it uniquely factorizes through $i : F_\alpha \xrightarrow{\sim} A_\alpha$. We first show that, for any $M \in \text{Rep}_\alpha(H)$,

$l \in M^*$, and $m \in M$, we have

$$(3.46) \quad \xi_M(l \otimes m) = \xi_{H_\alpha}(i_M(l \otimes m) \otimes 1_\alpha)$$

Indeed, let $\phi : H_\alpha \rightarrow M$ be the H_α -linear morphism given by $\phi(h) = h \cdot m$. Since ξ is a dinatural transformation, we have that $\xi_M(l \otimes \phi(1_\alpha)) = \xi_{H_\alpha}(\phi^*(l) \otimes 1_\alpha)$. This last equality is exactly (3.46), since $\phi^*(l) = i_M(l \otimes m)$.

Define now $r : A_\alpha \rightarrow Z$ by $f \mapsto r(f) = \xi_{H_\alpha}(f \otimes 1_\alpha)$. It is H_1 -linear since, for any $f \in A_\alpha$ and $h \in H_1$, we have

$$\begin{aligned} h \cdot r(f) &= h \cdot \xi_{H_\alpha}(f \otimes 1_\alpha) \\ &= \xi_{H_\alpha}(h \cdot (f \otimes 1_\alpha)) \quad \text{since } \xi_{H_\alpha} \text{ is } H_1\text{-linear} \\ &= \xi_{H_\alpha}(h_{(1, \alpha^{-1})} \cdot f \otimes h_{(2, \alpha)}) \\ &= \xi_{H_\alpha}(i_{H_\alpha}(h_{(1, \alpha^{-1})} \cdot f \otimes h_{(2, \alpha)}) \otimes 1_\alpha) \quad \text{by (3.46)} \\ &= \xi_{H_\alpha}((h \triangleright f) \otimes 1_\alpha) \quad \text{by the definition of the action } \triangleright \text{ of } H_1 \text{ on } A_\alpha \\ &= r(h \triangleright f). \end{aligned}$$

The map r factorizes ξ through the coend since (3.46) says exactly that $\xi_M = r \circ i_M$ for all the modules $M \in \text{Rep}_\alpha(H)$.

It remains to verify that this factorization is unique. Since $i_{H_\alpha} : H_\alpha^* \otimes H_\alpha \rightarrow A_\alpha$ is surjective (because $i_{H_\alpha}(H_\alpha^* \otimes 1_\alpha) = H_\alpha^* = A_\alpha$) and $r \circ i_{H_\alpha} = \xi_{H_\alpha}$, the map r is uniquely determined. This completes the proof of the lemma. \square

Let $H = \{H_\alpha\}_{\alpha \in \pi}$ be a finite type ribbon Hopf π -coalgebra and $\langle A_\alpha, i : F_\alpha \rightrightarrows A_\alpha \rangle$ be the coend of F_α as in Lemma 3.6(a). Since the π -category $\text{Rep}(H)$ of representations of H is ribbon, Theorem 3.5 ensures that the family $A = \{A_\alpha\}_{\alpha \in \pi}$ admits a structure of a Hopf π -algebra in the category $\text{Rep}_1(H)$. Moreover, using Lemma 3.6(b), its structural morphisms can be explicitly described in terms of the structure maps of the Hopf π -coalgebra $H = \{H_\alpha\}_{\alpha \in \pi}$. Nevertheless, it is more convenient to write down its pre-dual structural morphisms. Indeed, for example, since $A_\alpha = H_\alpha^*$ as a \mathbb{k} -space and $H = \{H_\alpha\}_{\alpha \in \pi}$ is of finite type, the pre-dual of the multiplication $m_{\alpha, \beta} : A_\alpha \otimes A_\beta \rightarrow A_{\alpha\beta}$ of A is a morphism $\Delta_{\alpha, \beta}^{\text{Bd}} : H_{\alpha\beta} \rightarrow H_\alpha \otimes H_\beta$ such that $(\Delta_{\alpha, \beta}^{\text{Bd}})^* = m_{\alpha, \beta}$. That yields a family $H^{\text{Bd}} = \{H_\alpha^{\text{Bd}}\}_{\alpha \in \pi}$ of \mathbb{k} -algebras, where $H_\alpha^{\text{Bd}} = H_\alpha$ as a \mathbb{k} -space, endowed with a comultiplication $\Delta^{\text{Bd}} = \{\Delta_{\alpha, \beta}^{\text{Bd}} : H_{\alpha\beta}^{\text{Bd}} \rightarrow H_\alpha^{\text{Bd}} \otimes H_\beta^{\text{Bd}}\}_{\alpha, \beta \in \pi}$, a counit $\varepsilon : H_1^{\text{Bd}} \rightarrow \mathbb{k}$, and an antipode $S^{\text{Bd}} = \{S_\alpha^{\text{Bd}} : H_\alpha^{\text{Bd}} \rightarrow H_{\alpha^{-1}}^{\text{Bd}}\}_{\alpha \in \pi}$. These structure maps, described in Lemma 3.7, verify the same axioms as those of a Hopf π -coalgebra except that the usual flip maps are replaced by the braiding of $\text{Rep}_1(H)$. The family $H^{\text{Bd}} = \{H_\alpha^{\text{Bd}}\}_{\alpha \in \pi}$ is called the *braided Hopf π -coalgebra associated to H* . When $\pi = 1$, we obtain a braided group in the sense of [31].

LEMMA 3.7. *Let $H = (\{H_\alpha\}, \Delta, \varepsilon, S, \varphi, R, \theta)$ be a finite type ribbon Hopf π -coalgebra. Then the structure maps of the braided Hopf π -coalgebra $H^{\text{Bd}} = \{H_\alpha^{\text{Bd}}\}_{\alpha \in \pi}$ associated to H can be described as follows: for any $\alpha, \beta \in \pi$,*

- $H_\alpha^{\text{Bd}} = H_\alpha$ as an algebra;
- for all $x \in H_{\alpha\beta}^{\text{Bd}}$,

$$\begin{aligned} \Delta_{\alpha, \beta}^{\text{Bd}}(x) &= x_{(2, \alpha)} a_\alpha \otimes S_{\beta^{-1}}(b_{1(1, \beta^{-1})}) \varphi_{\alpha^{-1}}(x_{(1, \alpha\beta\alpha^{-1})}) b_{1(2, \beta)} \\ &= S_{\alpha^{-1}}(c_{1(1, \alpha^{-1})}) x_{(1, \alpha)} c_{1(2, \alpha)} \otimes S_{\beta^{-1}}(d_{\beta^{-1}}) x_{(2, \beta)}, \end{aligned}$$

where $R_{\alpha, 1} = a_\alpha \otimes b_1$ and $R_{1, \beta^{-1}} = c_1 \otimes d_{\beta^{-1}}$;

- $\varepsilon^{\text{Bd}} = \varepsilon$;

- for all $x \in H_\alpha$,

$$\begin{aligned} S_\alpha^{\text{Bd}}(x) &= S_\alpha(a_\alpha)\theta_{\alpha^{-1}}^2 S_\alpha(x)u_{\alpha^{-1}}b_{\alpha^{-1}} \\ &= S_\alpha(a_\alpha)S_\alpha(x)S_\alpha(u_\alpha)^{-1}b_{\alpha^{-1}}, \end{aligned}$$

where $R_{\alpha,\alpha^{-1}} = a_\alpha \otimes b_{\alpha^{-1}}$ and the u_α are the Drinfeld elements of H .

Proof. Let $\alpha \in \pi$ and $f \in A_\alpha = H_\alpha^*$. By Lemma 3.6(b) and Theorem 3.5, the comultiplication Δ_α of A is given by

$$\begin{aligned} \Delta_\alpha(f) &= \Delta_{H_\alpha}(f \otimes 1_\alpha) \\ &= (i_{H_\alpha} \otimes i_{H_\alpha})(\text{ev}_{H_\alpha^*} \otimes \text{coev}_{H_\alpha} \otimes \text{id}_{H_\alpha})(f \otimes 1_\alpha) \\ &= \sum_k i_{H_\alpha}(f \otimes e_k) \otimes i_{H_\alpha}(e_k^* \otimes 1_\alpha), \end{aligned}$$

where $(e_k)_k$ is a basis for H_α with dual basis $(e_k^*)_k$. Therefore, for all $x, y \in H_\alpha$,

$$\begin{aligned} \langle \Delta_\alpha(f), x \otimes y \rangle &= \sum_k \langle i_{H_\alpha}(f \otimes e_k), x \rangle \langle i_{H_\alpha}(e_k^* \otimes 1_\alpha), y \rangle \\ &= \sum_k f(x \cdot e_k) e_k^*(y \cdot 1_\alpha) \\ &= f(x) \sum_k e_k^*(y) e_k \\ &= f(xy). \end{aligned}$$

Likewise the counit ε_α of A is given by $\varepsilon_\alpha(f) = \text{ev}_{H_\alpha}(f \otimes 1_\alpha) = f(1_\alpha)$. Hence $A_\alpha = H_\alpha^*$ as a coalgebra and so $H_\alpha^{\text{Bd}} = H_\alpha$ as an algebra.

Let $\alpha, \beta \in \pi$ and $f \in H_\alpha, g \in H_\beta$. By Lemma 3.6(b) and Theorem 3.5, the multiplication $m_{\alpha,\beta}$ of A is given by $m_{\alpha,\beta}(f \otimes g) = m_{H_\alpha, H_\beta}(f \otimes 1_\alpha \otimes g \otimes 1_\beta)$. Write $R_{\alpha,1} = a_\alpha \otimes b_1$. By (2.6), we have

$$(R_{\alpha,\beta})_{1\beta^{-1}3}(R_{\alpha,\beta^{-1}})_{12\beta} = (\text{id}_{H_\alpha} \otimes \Delta_{\beta^{-1},\beta})(R_{\alpha,1}) = a_\alpha \otimes b_{1(1,\beta^{-1})} \otimes b_{1(2,\beta)}.$$

Then $m_{\alpha,\beta}(f \otimes g) = i_{\varphi_\alpha(H_\beta) \otimes H_\alpha}(b_{1(1,\beta^{-1})} \cdot g \otimes f \otimes b_{1(2,\beta)} \otimes a_\alpha)$ and so, for any $x \in H_{\alpha\beta}$,

$$\begin{aligned} \langle m_{\alpha,\beta}(f \otimes g), x \rangle &= \langle b_{1(1,\beta^{-1})} \cdot g \otimes f, x \cdot (b_{1(2,\beta)} \otimes a_\alpha) \rangle \\ &= \langle f \otimes g, x_{(2,\alpha)} a_\alpha \otimes S_{\beta^{-1}}(b_{1(1,\beta^{-1})}) \varphi_{\alpha^{-1}}(x_{(1,\alpha\beta\alpha^{-1})}) b_{1(2,\beta)} \rangle. \end{aligned}$$

Hence we obtain that $\Delta_{\alpha,\beta}^{\text{Bd}}(x) = x_{(2,\alpha)} a_\alpha \otimes S_{\beta^{-1}}(b_{1(1,\beta^{-1})}) \varphi_{\alpha^{-1}}(x_{(1,\alpha\beta\alpha^{-1})}) b_{1(2,\beta)}$ for any $x \in H_{\alpha\beta}^{\text{Bd}}$.

Note that, by using the commutativity property of dinatural transformations (see Figure 3.4), the morphism $m_{X,Y}$ defined in Figure 3.13(a) where $X \in \text{Rep}_\alpha(H)$ and $Y \in \text{Rep}_\beta(H)$ can also be depicted as in Figure 3.21(a). Write $R_{1,\beta^{-1}} = c_1 \otimes d_{\beta^{-1}}$. By (2.6) we have

$$[(\text{id}_{H_{\alpha^{-1}}} \otimes \varphi_{\alpha^{-1}})(R_{\alpha,\alpha\beta^{-1}\alpha^{-1}})]_{1\alpha^{-1}3}(R_{\alpha,\beta^{-1}})_{\alpha 23} = (\Delta_{\alpha^{-1},\alpha} \otimes \text{id}_{H_{\beta^{-1}}})(R_{1,\beta^{-1}}) = c_{1(1,\alpha^{-1})} \otimes c_{1(2,\alpha)} \otimes d_{\beta^{-1}}.$$

Then $m_{\alpha,\beta}(f \otimes g) = i_{H_\alpha \otimes H_\beta}(c_{1(1,\alpha^{-1})} \cdot f \otimes d_{\beta^{-1}} \cdot g \otimes c_{1(2,\alpha)} \otimes 1_\beta)$ and so, for any $x \in H_{\alpha\beta}$,

$$\begin{aligned} \langle m_{\alpha,\beta}(f \otimes g), x \rangle &= \langle c_{1(1,\alpha^{-1})} \cdot f \otimes d_{\beta^{-1}} \cdot g, x \cdot (c_{1(2,\alpha)} \otimes 1_\beta) \rangle \\ &= \langle f \otimes g, S_{\alpha^{-1}}(c_{1(1,\alpha^{-1})}) x_{(1,\alpha)} c_{1(2,\alpha)} \otimes S_{\beta^{-1}}(d_{\beta^{-1}}) x_{(2,\beta)} \rangle. \end{aligned}$$

Hence we obtain that $\Delta_{\alpha,\beta}^{\text{Bd}}(x) = S_{\alpha^{-1}}(c_{1(1,\alpha^{-1})}) x_{(1,\alpha)} c_{1(2,\alpha)} \otimes S_{\beta^{-1}}(d_{\beta^{-1}}) x_{(2,\beta)}$ for any $x \in H_{\alpha\beta}^{\text{Bd}}$.

The unit η of A is given by $\eta : \mathbb{k} \cong \mathbb{k} \otimes \mathbb{k} \xrightarrow{i_{\mathbb{k}}} A_1$. Therefore, for any $h \in H_1$, we get that $\varepsilon^{\text{Bd}}(h) = \langle i_{\mathbb{k}}(1 \otimes 1), h \rangle = \langle 1, h \cdot 1 \rangle = \varepsilon(h)$.

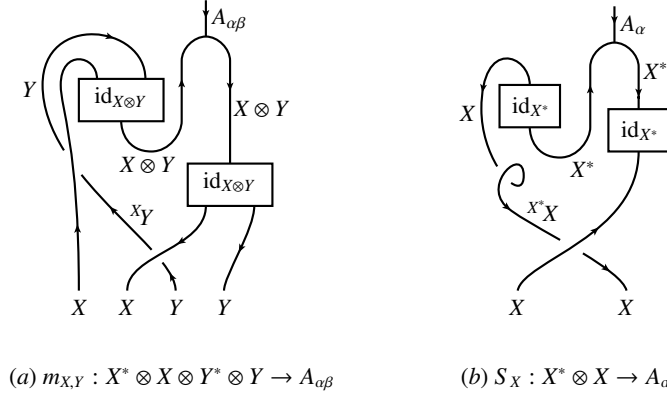

FIGURE 3.21.

Let $M \in \text{Rep}_{\alpha^{-1}}(H)$ and $m \in M$. Define $\phi_m \in M^{**}$ by setting $\phi_m = (\tilde{e}_v_M \otimes \text{id}_{M^{**}})(m \otimes \text{coev}_{M^*})$. Let $(e_k)_k$ be a basis for M with dual basis $(e_k^*)_k$ and bidual basis $(e_k^{**})_k$. Using Lemma 3.1, we have

$$\phi_m = \sum_k \tilde{e}_v_M(m \otimes e_k^*) e_k^{**} = \sum_k e_k^*(G_\alpha \cdot m) e_k^{**}$$

and so, for any $f \in M^*$,

$$\phi_m(f) = \sum_k e_k^*(G_\alpha \cdot m) e_k^{**}(f) = \sum_k e_k^*(G_\alpha \cdot m) f(e_k) = f\left(\sum_k e_k^*(G_\alpha \cdot m) e_k\right) = f(G_\alpha \cdot m).$$

Finally let $\alpha \in \pi$ and $f \in A_{\alpha^{-1}} = H_{\alpha^{-1}}^*$. By Lemma 3.6(b) and Theorem 3.5, the antipode S_α of A is given by $S_\alpha(f) = S_{H_{\alpha^{-1}}}(f \otimes 1_{\alpha^{-1}}) = i_{\varphi_{\alpha^{-1}}(H_{\alpha^{-1}})^*}(\phi_{b_{\alpha^{-1}}} \otimes \theta_\alpha a_\alpha \cdot f)$ where $R_{\alpha, \alpha^{-1}} = a_\alpha \otimes b_{\alpha^{-1}}$. Then, for any $x \in H_\alpha$,

$$\begin{aligned} \langle S_\alpha(f), x \rangle &= \langle \phi_{b_{\alpha^{-1}}}, x \cdot (\theta_\alpha a_\alpha \cdot f) \rangle \\ &= \langle \phi_{b_{\alpha^{-1}}}, \varphi_\alpha(x) \theta_\alpha a_\alpha \cdot f \rangle \\ &= \langle \varphi_\alpha(x) \theta_\alpha a_\alpha \cdot f, G_{\alpha^{-1}} b_{\alpha^{-1}} \rangle \\ &= \langle f, S_\alpha(a_\alpha) \theta_{\alpha^{-1}} S_\alpha(\varphi_\alpha(x)) G_{\alpha^{-1}} b_{\alpha^{-1}} \rangle. \end{aligned}$$

Now, using Lemmas 2.1(c) and 2.8(a), we have

$$S_\alpha(\varphi_\alpha(x)) G_\alpha = \varphi_\alpha(S_\alpha(x)) G_\alpha = \theta_{\alpha^{-1}} S_\alpha(x) \theta_{\alpha^{-1}}^{-1} G_{\alpha^{-1}} = \theta_{\alpha^{-1}} S_\alpha(x) u_{\alpha^{-1}}.$$

Therefore $\langle S_\alpha(f), x \rangle = \langle f, S_\alpha(a_\alpha) \theta_{\alpha^{-1}}^2 S_\alpha(x) u_{\alpha^{-1}} b_{\alpha^{-1}} \rangle$. Hence we obtain that, for any $x \in H_\alpha^{\text{Bd}}$, $S_\alpha^{\text{Bd}}(x) = S_\alpha(a_\alpha) \theta_{\alpha^{-1}}^2 S_\alpha(x) u_{\alpha^{-1}} b_{\alpha^{-1}}$.

By using the commutativity property of dinatural transformations, the morphism S_X defined in Figure 3.13(b) where $X \in \text{Rep}_{\alpha^{-1}}(H)$ can also be depicted as in Figure 3.21(b). Then we have that $S_{H_{\alpha^{-1}}}(f \otimes 1_{\alpha^{-1}}) = i_{H_{\alpha^{-1}}}(\phi_{\theta_{\alpha^{-1}} b_{\alpha^{-1}}} \otimes a_\alpha \cdot f)$ and so, for any $x \in H_\alpha$,

$$\begin{aligned} \langle S_\alpha(f), x \rangle &= \langle \phi_{\theta_{\alpha^{-1}} b_{\alpha^{-1}}}, x a_\alpha \cdot f \rangle \\ &= \langle x a_\alpha \cdot f, G_{\alpha^{-1}} \theta_{\alpha^{-1}} b_{\alpha^{-1}} \rangle \\ &= \langle f, S_\alpha(a_\alpha) S_\alpha(x) G_{\alpha^{-1}} \theta_{\alpha^{-1}} b_{\alpha^{-1}} \rangle. \end{aligned}$$

Now $S(u_\alpha) = S_\alpha(G_\alpha \theta_\alpha^{-1}) = \theta_\alpha^{-1} G_\alpha^{-1}$ by (2.14) and Lemma 2.9(c) and so $G_{\alpha^{-1}} \theta_{\alpha^{-1}} = S_\alpha(u_\alpha)^{-1}$. Therefore $\langle S_\alpha(f), x \rangle = \langle f, S_\alpha(a_\alpha) S_\alpha(x) S_\alpha(u_\alpha)^{-1} b_{\alpha^{-1}} \rangle$. Hence we obtain that, for any $x \in H_\alpha^{\text{Bd}}$, $S_\alpha^{\text{Bd}}(x) = S_\alpha(a_\alpha) S_\alpha(x) S_\alpha(u_\alpha)^{-1} b_{\alpha^{-1}}$. This completes the proof of the corollary. \square

In the next theorem, we relate the right π -integrals for the Hopf π -coalgebra $H = \{H_\alpha\}_{\alpha \in \pi}$ with the right π -integrals for the categorical Hopf π -algebra $A = \{A_\alpha\}_{\alpha \in \pi}$.

THEOREM 3.8. *Let $H = \{H_\alpha\}_{\alpha \in \pi}$ be a finite type unimodular ribbon Hopf π -coalgebra and $A = \{A_\alpha\}_{\alpha \in \pi}$ be the Hopf π -algebra in $\text{Rep}_1(H)$ constructed from H as above. Let $\lambda = (\lambda_\alpha)_{\alpha \in \pi} \in \prod_{\alpha \in \pi} H_\alpha^*$. For any $\alpha \in \pi$, define $\mu_\alpha : \mathbf{k} \rightarrow A_\alpha$ by $\mu_\alpha(1) = \lambda_\alpha$. Then the following assertions are equivalent:*

- (a) $\lambda = (\lambda_\alpha)_{\alpha \in \pi}$ is a right π -integral for H ;
- (b) $\mu = (\mu_\alpha)_{\alpha \in \pi}$ is a right π -integral for A .

Note that one may add in Theorem 3.8 a third item giving an equivalent version of (a), (b) in terms of the braided Hopf π -coalgebra $H^{\text{Bd}} = \{H_\alpha^{\text{Bd}}\}_{\alpha \in \pi}$ associated to H (see Lemma 3.7). Nevertheless, we do not want to do it here since this would take too much place (in particular, one has to generalize Theorem 1.16 to the setting of braided Hopf π -coalgebras) and we do not use it in the sequel.

Before proving Theorem 3.8, we need some lemmas. Recall that \triangleright denotes the left action of H_1 on $A_\alpha = H_\alpha^*$ given by $\langle h \triangleright f, x \rangle = \langle f, S_{\alpha^{-1}}(h_{(1, \alpha^{-1})}) x h_{(2, \alpha)} \rangle$ for all $h \in H_1$, $x \in H_\alpha$, and $f \in H_\alpha^*$.

LEMMA 3.9. *Let $H = \{H_\alpha\}_{\alpha \in \pi}$ be a finite type ribbon Hopf π -coalgebra and $H^{\text{Bd}} = \{H_\alpha^{\text{Bd}}\}_{\alpha \in \pi}$ be its associated braided Hopf π -coalgebra. Let $\alpha \in \pi$ and $f \in H_\alpha^*$. If $h \triangleright f = \varepsilon(h) f$ for all $h \in H_1$, then $(f \otimes \text{id}_{H_\beta}) \Delta_{\alpha, \beta}^{\text{Bd}} = (f \otimes \text{id}_{H_\beta}) \Delta_{\alpha, \beta}$ for all $\beta \in \pi$.*

Proof. Let $\beta \in \pi$. Write $R_{1, \beta^{-1}} = c_1 \otimes d_{\beta^{-1}}$. For all $x \in H_{\alpha\beta}$, we have

$$\begin{aligned} (f \otimes \text{id}_{H_\beta}) \Delta_{\alpha, \beta}^{\text{Bd}}(x) &= \langle f, S_{\alpha^{-1}}(c_{1(1, \alpha^{-1})}) x_{(1, \alpha)} c_{1(2, \alpha)} \rangle S_{\beta^{-1}}(d_{\beta^{-1}}) x_{(2, \beta)} \quad \text{by Lemma 3.7} \\ &= \langle c_1 \triangleright f, x_{(1, \alpha)} \rangle S_{\beta^{-1}}(d_{\beta^{-1}}) x_{(2, \beta)} \\ &= \langle \varepsilon(c_1) f, x_{(1, \alpha)} \rangle S_{\beta^{-1}}(d_{\beta^{-1}}) x_{(2, \beta)} \\ &= \langle f, x_{(1, \alpha)} \rangle S_{\beta^{-1}}(\varepsilon(c_1) d_{\beta^{-1}}) x_{(2, \beta)} \\ &= \langle f, x_{(1, \alpha)} \rangle S_{\beta^{-1}}(1_\beta) x_{(2, \beta)} \quad \text{by Lemma 2.4(a)} \\ &= (f \otimes \text{id}_{H_\beta}) \Delta_{\alpha, \beta}(x). \end{aligned}$$

\square

LEMMA 3.10. *Let $H = \{H_\alpha\}_{\alpha \in \pi}$ be a finite type unimodular ribbon Hopf π -coalgebra and $\lambda = (\lambda_\alpha)_{\alpha \in \pi}$ be a right π -integral for H . Then, for any $\alpha \in \pi$, $x \in H_\alpha$, and $h \in H_1$,*

$$\lambda_\alpha(S_{\alpha^{-1}}(h_{(1, \alpha^{-1})}) x h_{(2, \alpha)}) = \varepsilon(h) \lambda_\alpha(x).$$

Proof. We can suppose that λ is non-zero (otherwise the result is immediate). Let $\Lambda \in H_1$ be a right integral for H_1 such that $\lambda_\alpha(\Lambda) = 1$. Recall that Λ is also a left integral for H_1 (since H is unimodular). Then

$$\begin{aligned} &\lambda_\alpha(S_{\alpha^{-1}}(h_{(1, \alpha^{-1})}) x h_{(2, \alpha)}) \\ &= \lambda_{\alpha^{-1}}(\Lambda_{(1, \alpha^{-1})} h_{(1, \alpha^{-1})}) \lambda_\alpha(\Lambda_{(2, \alpha)} x h_{(2, \alpha)}) \quad \text{by Lemma 1.17(a)} \\ &= \lambda_{\alpha^{-1}}(S_\alpha S_{\alpha^{-1}}(h_{(1, \alpha^{-1})}) \leftarrow \varepsilon) \Lambda_{(1, \alpha^{-1})}) \lambda_\alpha(S_{\alpha^{-1}} S_\alpha(h_{(2, \alpha)}) \Lambda_{(2, \alpha)} x) \quad \text{by Theorem 1.16(a)} \\ &= \lambda_{\alpha^{-1}}(S_\alpha S_{\alpha^{-1}}(h_{(1, \alpha^{-1})}) \Lambda_{(1, \alpha^{-1})}) \lambda_\alpha(S_{\alpha^{-1}} S_\alpha(h_{(2, \alpha)}) \Lambda_{(2, \alpha)} x). \end{aligned}$$

Now

$$S_\alpha S_{\alpha^{-1}}(h_{(1, \alpha^{-1})}) \Lambda_{(1, \alpha^{-1})} \otimes S_{\alpha^{-1}} S_\alpha(h_{(2, \alpha)}) \Lambda_{(2, \alpha)}$$

$$\begin{aligned}
&= (S_\alpha S_{\alpha^{-1}} \otimes S_{\alpha^{-1}} S_\alpha) \Delta_{\alpha^{-1}, \alpha}(h) \cdot \Delta_{\alpha^{-1}, \alpha}(\Lambda) \\
&= \Delta_{\alpha^{-1}, \alpha}(S_1^2(h)) \cdot \Delta_{\alpha^{-1}, \alpha}(\Lambda) \quad \text{by Lemma 1.1(c)} \\
&= \Delta_{\alpha^{-1}, \alpha}(S_1^2(h)\Lambda) \quad \text{by (1.4)} \\
&= \varepsilon(S_1^2(h)) \Delta_{\alpha^{-1}, \alpha}(\Lambda) \quad \text{since } \Lambda \text{ is a left integral for } H_1 \\
&= \varepsilon(h) \Lambda_{(1, \alpha^{-1})} \otimes \Lambda_{(2, \alpha)} \quad \text{by Lemma 1.1(d)}.
\end{aligned}$$

Therefore, using (1.12), we obtain that

$$\lambda_\alpha(S_{\alpha^{-1}}(h_{(1, \alpha^{-1})})xh_{(2, \alpha)}) = \varepsilon(h) \lambda_{\alpha^{-1}}(\Lambda_{(1, \alpha^{-1})}) \lambda_\alpha(\Lambda_{(2, \alpha)}x) = \varepsilon(h) \lambda_\alpha(\lambda_1(\Lambda)1_\alpha x) = \varepsilon(h) \lambda_\alpha(x).$$

□

Proof of Theorem 3.8. Suppose that $\lambda = (\lambda_\alpha)_{\alpha \in \pi}$ is a right π -integral for H . By Lemma 3.10, we have that $h \triangleright \lambda_\alpha = \varepsilon(h) \lambda_\alpha$ for all $\alpha \in \pi$ and $h \in H_1$. Therefore, using (1.12) and Lemmas 3.7 and 3.9, we have that

$$(\lambda_\alpha \otimes \text{id}_{H_\beta}) \Delta_{\alpha, \beta}^{\text{Bd}} = (\lambda_\alpha \otimes \text{id}_{H_\beta}) \Delta_{\alpha, \beta} = \lambda_{\alpha\beta} 1_\beta = \lambda_{\alpha\beta} 1_\beta^{\text{Bd}}$$

for all $\alpha, \beta \in \pi$. Hence, since the structural morphisms of A are dual to those of H^{Bd} , we get that $m_{\alpha, \beta}(\mu_\alpha \otimes \text{id}_{A_\beta}) = \mu_{\alpha\beta} \varepsilon_\beta$ for all $\alpha, \beta \in \pi$, where $m = \{m_{\alpha, \beta}\}_{\alpha, \beta \in \pi}$ and $\varepsilon = \{\varepsilon_\alpha\}_{\alpha \in \pi}$ denote the multiplication and counit of A . Moreover, Lemma 3.10 says exactly that all the $\mu_\alpha : \mathbb{k} \rightarrow A_\alpha$ are H_1 -linear. Therefore $\mu = (\mu_\alpha)_{\alpha \in \pi}$ is a right π -integral for A .

Suppose that $\mu = (\mu_\alpha)_{\alpha \in \pi}$ is a right π -integral for A . Therefore, since the structural morphisms of H^{Bd} are pre-dual to those of A , (3.43) gives that $(\lambda_\alpha \otimes \text{id}_{H_\beta}) \Delta_{\alpha, \beta}^{\text{Bd}} = \lambda_{\alpha\beta} 1_\beta^{\text{Bd}}$ for all $\alpha, \beta \in \pi$. Since all the $\mu_\alpha : \mathbb{k} \rightarrow A_\alpha$ are H_1 -linear, we have that $h \triangleright \lambda_\alpha = h \triangleright \mu_\alpha(1) = \mu_\alpha(h \cdot 1) = \varepsilon(h) \mu_\alpha(1) = \varepsilon(h) \lambda_\alpha$ for all $\alpha \in \pi$ and $h \in H_1$ and so, by Lemma 3.9, $(\lambda_\alpha \otimes \text{id}_{H_\beta}) \Delta_{\alpha, \beta}^{\text{Bd}} = (\lambda_\alpha \otimes \text{id}_{H_\beta}) \Delta_{\alpha, \beta}$ for all $\alpha, \beta \in \pi$. Hence, since $1_\beta^{\text{Bd}} = 1_\beta$ by Lemma 3.7, we get that $(\lambda_\alpha \otimes \text{id}_{H_\beta}) \Delta_{\alpha, \beta} = \lambda_{\alpha\beta} 1_\beta$, that is, $\lambda = (\lambda_\alpha)_{\alpha \in \pi}$ is a right π -integral for H . □

3.4.2. Coends in a finitely semisimple π -category. Let $C = \coprod_{\alpha \in \pi} C_\alpha$ be a finitely semisimple π -category. Fix $\alpha \in \pi$. Recall that the set J_α of isomorphism classes of simple objects of C_α is finite. Let $\{V_j^\alpha\}_{j \in J_\alpha}$ be a representative set of J_α . We set:

$$(3.47) \quad B_\alpha = \bigoplus_{j \in J_\alpha} (V_j^\alpha)^* \otimes V_j^\alpha \in C_1.$$

Recall that there exist morphisms $p_j^\alpha : B_\alpha \rightarrow (V_j^\alpha)^* \otimes V_j^\alpha$ and $q_j^\alpha : (V_j^\alpha)^* \otimes V_j^\alpha \rightarrow B_\alpha$ such that

$$(3.48) \quad \text{id}_{B_\alpha} = \sum_{j \in J_\alpha} q_j^\alpha \circ p_j^\alpha \quad \text{and} \quad p_j^\alpha \circ q_k^\alpha = \begin{cases} \text{id}_{(V_j^\alpha)^* \otimes V_j^\alpha} & \text{if } j = k \\ 0 & \text{otherwise} \end{cases}.$$

Let X be an object of C_α . By (3.31), we can write $X = \bigoplus_{\lambda \in \Lambda} V_{j_\lambda}$, where Λ is a finite set and $j_\lambda \in J_\alpha$. In particular, there exist morphisms $f_\lambda : X \rightarrow V_{j_\lambda}^\alpha$ and $g_\lambda : V_{j_\lambda}^\alpha \rightarrow X$ with

$$(3.49) \quad \text{id}_X = \sum_{\lambda \in \Lambda} g_\lambda \circ f_\lambda \quad \text{and} \quad f_\lambda \circ g_{\lambda'} = \begin{cases} \text{id}_{V_{j_\lambda}^\alpha} & \text{if } \lambda = \lambda' \\ 0 & \text{otherwise} \end{cases}.$$

We set

$$(3.50) \quad i'_X = \sum_{\lambda \in \Lambda} q_{j_\lambda} \circ (g_{j_\lambda}^* \otimes f_{j_\lambda}) : X^* \otimes X \rightarrow B_\alpha.$$

Let $F_\alpha : C_\alpha^{\text{op}} \times C_\alpha \rightarrow C_1$ be the functor defined as in (3.33).

LEMMA 3.11. $\langle B_\alpha, i' : F_\alpha \rightrightarrows B_\alpha \rangle$ is a coend of F_α .

Proof. We first remark that, for any $j \in J_\alpha$,

$$(3.51) \quad i'_{V_j^\alpha} = q_j^\alpha.$$

Indeed let $f, g \in \text{End}_{C_\alpha}(V_j^\alpha)$ such that $\text{id}_{V_j^\alpha} = g \circ f$. Since V_j^α is a simple object of C_α , there exists $k \in \mathbb{k}$ such that $f = k \text{id}_{V_j^\alpha}$. Since $\text{id}_{V_j^\alpha} = g \circ f$, the scalar k is non-zero and $g = k^{-1} \text{id}_{V_j^\alpha}$. Therefore $\xi_{V_j^\alpha} = q_j^\alpha \circ (g^* \otimes f) = q_j^\alpha \circ (k^{-1} \text{id}_{(V_j^\alpha)^*} \otimes k \text{id}_{V_j^\alpha}) = q_j^\alpha \circ (\text{id}_{(V_j^\alpha)^*} \otimes \text{id}_{V_j^\alpha}) = q_j^\alpha$.

Let us verify that $i' : F_\alpha \xrightarrow{\sim} B_\alpha$ is a dinatural transformation. We first show that, for any $j, k \in J_\alpha$ and any morphism $f : V_j^\alpha \rightarrow V_k^\alpha$ in C_α , we have

$$(3.52) \quad q_k^\alpha(\text{id}_{(V_k^\alpha)^*} \otimes f) = q_j^\alpha(f^* \otimes \text{id}_{V_j^\alpha}) : (V_k^\alpha)^* \otimes V_j^\alpha \rightarrow B_\alpha.$$

If $j \neq k$ then $f = 0$ (since V_j^α and V_k^α are non-isomorphic simple objects) and so both sides of (3.52) equal 0. If $j = k$, then there exists $x \in \mathbb{k}$ with $f = x \text{id}_{V_j^\alpha}$. Therefore $f^* = x \text{id}_{(V_j^\alpha)^*}$ and so $q_j^\alpha(\text{id}_{(V_j^\alpha)^*} \otimes f) = x q_j^\alpha(\text{id}_{(V_j^\alpha)^*} \otimes \text{id}_{V_j^\alpha}) = q_j^\alpha(f^* \otimes \text{id}_{V_j^\alpha})$. Hence (3.52) is proven.

Let $\phi : X \rightarrow X'$ be a morphism in C_α . By (3.31), $X = \bigoplus_{\lambda \in \Lambda} V_{j_\lambda}^\alpha$ and $X' = \bigoplus_{\lambda' \in \Lambda'} V_{j_{\lambda'}}^\alpha$ where Λ, Λ' are finite sets and $j_\lambda, j_{\lambda'} \in J_\alpha$. In particular, there exist morphisms $f_\lambda : X \rightarrow V_{j_\lambda}^\alpha, g_\lambda : V_{j_\lambda}^\alpha \rightarrow X, f'_{\lambda'} : X' \rightarrow V_{j_{\lambda'}}^\alpha$, and $g'_{\lambda'} : V_{j_{\lambda'}}^\alpha \rightarrow X'$ with

$$(3.53) \quad \text{id}_X = \sum_{\lambda \in \Lambda} g_\lambda \circ f_\lambda \quad \text{and} \quad \text{id}_{X'} = \sum_{\lambda' \in \Lambda'} g'_{\lambda'} \circ f'_{\lambda'}.$$

Then

$$\begin{aligned} i'_{X'} \circ (\text{id}_{X'^*} \otimes \phi) &= \sum_{\lambda' \in \Lambda'} q_{j_{\lambda'}}^\alpha (g'_{j_{\lambda'}}{}^* \otimes f'_{j_{\lambda'}} \phi) \quad \text{by (3.50)} \\ &= \sum_{\lambda' \in \Lambda'} q_{j_{\lambda'}}^\alpha (g'_{j_{\lambda'}}{}^* \otimes f'_{j_{\lambda'}} \phi \circ (\sum_{\lambda \in \Lambda} g_\lambda \circ f_\lambda)) \quad \text{by (3.53)} \\ &= \sum_{\lambda \in \Lambda} \sum_{\lambda' \in \Lambda'} q_{j_{\lambda'}}^\alpha (\text{id}_{(V_{j_{\lambda'}}^\alpha)^*} \otimes (f'_{j_{\lambda'}} \phi g_\lambda))(g'_{j_{\lambda'}}{}^* \otimes f_\lambda) \\ &= \sum_{\lambda \in \Lambda} \sum_{\lambda' \in \Lambda'} q_{j_{\lambda'}}^\alpha ((f'_{j_{\lambda'}} \phi g_\lambda)^* \otimes \text{id}_{V_{j_\lambda}^\alpha})(g'_{j_{\lambda'}}{}^* \otimes f_\lambda) \quad \text{by (3.52)} \\ &= \sum_{\lambda \in \Lambda} q_{j_\lambda}^\alpha (g_\lambda^* \phi^* \circ (\sum_{\lambda' \in \Lambda'} g'_{j_{\lambda'}} f'_{j_{\lambda'}})^* \otimes f_\lambda) \\ &= \sum_{\lambda \in \Lambda} q_{j_\lambda}^\alpha (g_\lambda^* \phi^* \otimes f_\lambda) \quad \text{by (3.53)} \\ &= i'_X \circ (\phi^* \otimes \text{id}_X) \quad \text{by (3.50)}. \end{aligned}$$

Hence $i' : F_\alpha \xrightarrow{\sim} B_\alpha$ is a dinatural transformation.

Let $\xi : F_\alpha \xrightarrow{\sim} Z$ be a dinatural transformation from F_α to an object $Z \in C_1$. We have to verify that it uniquely factorizes through i' . We first show the uniqueness of the factorization: let us suppose that there exists $h : B_\alpha \rightarrow Z$ with $\xi_X = h \circ i'_X$ for all object $X \in C_\alpha$. Therefore, using (3.48) and (3.51), we have

$$h = h \circ \text{id}_{B_\alpha} = h \circ (\sum_{j \in J_\alpha} q_j^\alpha \circ p_j^\alpha) = \sum_{j \in J_\alpha} (h \circ q_j^\alpha) \circ p_j^\alpha = \sum_{j \in J_\alpha} \xi_{V_j^\alpha} \circ p_j^\alpha,$$

and so h is uniquely determined.

It remains to show that $h = \sum_{j \in J_\alpha} \xi_{V_j^\alpha} \circ p_j^\alpha$ is suitable. Let an object $X = \bigoplus_{\lambda \in \Lambda} V_{j_\lambda}^\alpha \in C_\alpha$, where Λ is a finite set and $j_\lambda \in J_\alpha$. In particular there exist $f_\lambda : X \rightarrow V_{j_\lambda}^\alpha$ and $g_\lambda : V_{j_\lambda}^\alpha \rightarrow X$ morphisms

in C_α with $\text{id}_X = \sum_{\lambda \in \Lambda} g_\lambda \circ f_\lambda$, $f_\lambda \circ g_\lambda = \text{id}_{V_{j_\lambda}^\alpha}$, and $f_\lambda \circ g_{\lambda'} = 0$ if $\lambda \neq \lambda'$. Since ξ is a dinatural transformation, we have that, for any $\lambda \in \Lambda$,

$$(3.54) \quad \xi_X \circ (\text{id}_{X^*} \otimes g_\lambda) = \xi_{V_{j_\lambda}^\alpha} \circ (g_\lambda^* \otimes \text{id}_X).$$

Then

$$\begin{aligned} \xi_X &= \xi_X \circ (\text{id}_{X^*} \otimes (\sum_{\lambda \in \Lambda} g_\lambda \circ f_\lambda)) \\ &= \sum_{\lambda \in \Lambda} \xi_X \circ (\text{id}_{X^*} \otimes g_\lambda) \circ (\text{id}_{X^*} \otimes f_\lambda) \\ &= \sum_{\lambda \in \Lambda} \xi_{V_{j_\lambda}^\alpha} \circ (g_\lambda^* \otimes f_\lambda) \quad \text{by (3.54)} \\ &= \sum_{\lambda \in \Lambda} \xi_{V_{j_\lambda}^\alpha} \circ \text{id}_{(V_{j_\lambda}^\alpha)^* \otimes V_{j_\lambda}^\alpha} \circ (g_\lambda^* \otimes f_\lambda) \\ &= \sum_{\lambda \in \Lambda} \xi_{V_{j_\lambda}^\alpha} \circ p_{j_\lambda}^\alpha \circ q_{j_\lambda}^\alpha \circ (g_\lambda^* \otimes f_\lambda) \quad \text{by (3.48)} \\ &= \sum_{k \in J_\alpha} \xi_{V_k^\alpha} \circ p_k^\alpha \circ (\sum_{\substack{\lambda \in \Lambda \\ j_\lambda = k}} q_{j_\lambda}^\alpha \circ (g_\lambda^* \otimes f_\lambda)) \\ &= (\sum_{k \in J_\alpha} \xi_{V_k^\alpha} \circ p_k^\alpha) \circ (\sum_{\lambda \in \Lambda} q_{j_\lambda}^\alpha \circ (g_\lambda^* \otimes f_\lambda)) \quad \text{since } p_k^\alpha \circ q_{j_\lambda}^\alpha = 0 \text{ if } k \neq j_\lambda \\ &= h \circ i'_X. \end{aligned}$$

This completes the proof of the lemma. \square

Let us suppose that $C = \coprod_{\alpha \in \pi} C_\alpha$ is moreover ribbon, that is, C is premodular. By Theorem 3.5(a), the family $B = \{B_\alpha\}_{\alpha \in \pi}$ is a Hopf π -algebra in C_1 . Note that since the object $\mathbb{1} \in C_1$ is simple, there exists a (unique) $0 \in J_1$ such that $V_0^1 \cong \mathbb{1}$. Up to replacing V_0^1 by $\mathbb{1}$, we can assume that $V_0^1 = \mathbb{1}$.

LEMMA 3.12. $e = p_0^1 : B_1 \rightarrow \mathbb{1}$ is a non-zero left and right cointegral for the categorical Hopf algebra B_1 .

Proof. Recall that $i'_{V_j^\alpha} = q_j^\alpha$ for any $j \in J_\alpha$, see (3.51). We first remark that, for any $j \in J_1$,

$$(3.55) \quad (\text{id}_{B_1} \otimes e)\Delta_1 \circ i'_{V_j^1} = \eta e \circ i'_{V_j^1}$$

Indeed, since $i'_{V_j^1} = q_j^1$ and by (3.48), we have

$$\begin{aligned} (\text{id}_{B_1} \otimes e)\Delta_1 \circ i'_{V_j^1} &= (\text{id}_{B_1} \otimes p_0^1)(q_j^1 \otimes q_j^1)(\text{id}_{(V_j^1)^*} \otimes \text{coev}_{V_j^1} \otimes \text{id}_{V_j^1}) \\ &= (q_j^1 \otimes p_0^1 q_j^1)(\text{id}_{(V_j^1)^*} \otimes \text{coev}_{V_j^1} \otimes \text{id}_{V_j^1}) \\ &= \begin{cases} (q_0^1 \otimes \text{id}_{\mathbb{1}})(\text{id}_{\mathbb{1}} \otimes \text{coev}_{\mathbb{1}} \otimes \text{id}_{\mathbb{1}}) = q_0^1 & \text{if } j = 0 \\ 0 & \text{if } j \neq 0 \end{cases} \end{aligned}$$

and

$$\eta e \circ i'_{V_j^1} = i_{\mathbb{1}} p_0^1 q_j^1 = q_0^1 p_0^1 q_j^1 = \begin{cases} q_0^1 & \text{if } j = 0 \\ 0 & \text{if } j \neq 0. \end{cases}$$

Let $X \in C_1$. By (3.31), $X = \bigoplus_{\lambda \in \Lambda} V_{j_\lambda}^1$, where Λ is a finite set and $j_\lambda \in J_1$. There exist $f_\lambda : X \rightarrow V_{j_\lambda}^1$ and $g_\lambda : V_{j_\lambda}^1 \rightarrow X$ morphisms in C_1 with $\text{id}_X = \sum_{\lambda \in \Lambda} g_\lambda \circ f_\lambda$, $f_\lambda \circ g_\lambda = \text{id}_{V_{j_\lambda}^1}$, and $f_\lambda \circ g_{\lambda'} = 0$ if $\lambda \neq \lambda'$. Then

$$\begin{aligned} (\text{id}_{B_1} \otimes e)\Delta_1 \circ i'_X &= \sum_{\lambda \in \Lambda} (\text{id}_{B_1} \otimes e)\Delta_1 i'_{V_j^1} (g_{j_\lambda}^* \otimes f_{j_\lambda}) \quad \text{by (3.50)} \\ &= \sum_{\lambda \in \Lambda} \eta e \circ i'_{V_j^1} (g_{j_\lambda}^* \otimes f_{j_\lambda}) \quad \text{by (3.55)} \\ &= \eta e \circ i'_X \quad \text{by (3.50)} \end{aligned}$$

Hence, by the uniqueness of the factorization of the dinatural transformation $(\text{id}_{B_1} \otimes e)\Delta_1 \circ i : F_1 \rightarrow B_1$ through the coend $\langle B_1, i' : F_1 \rightarrow B_1 \rangle$, we obtain $(\text{id}_{B_1} \otimes e)\Delta_1 = \eta e$.

Likewise we can show that $(e \otimes \text{id}_{B_1})\Delta_1 = \eta e$. Finally, since $e q_0^1 = p_0^1 q_0^1 = \text{id}_{\mathbb{1}}$, we have that e is non-zero. \square

LEMMA 3.13. *Let $\mu = \{\mu_\alpha\}_{\alpha \in \pi}$ be a right π -integral for the categorical Hopf π -algebra $B = \{B_\alpha\}_{\alpha \in \pi}$. Then there exists $k \in \mathbb{k}$ such that, for all $\alpha \in \pi$,*

$$\mu_\alpha = k \sum_{j \in J_\alpha} \dim_q(V_j^\alpha) i'_{V_j^\alpha} \circ \widetilde{\text{coev}}_{V_j^\alpha}.$$

Proof. Recall that $i'_{V_j^\alpha} = q_j^\alpha$ for any $j \in J_\alpha$, see (3.51). We first remark that, for any $\alpha \in \pi$, there exists a family of scalars $(x_j^\alpha)_{j \in J_\alpha} \in \mathbb{k}^{J_\alpha}$ such that

$$\mu_\alpha = \sum_{j \in J_\alpha} x_j^\alpha q_j^\alpha \widetilde{\text{coev}}_{V_j^\alpha}.$$

Indeed, for any $j \in J_\alpha$, since the object V_j^α is simple, there exists a (unique) scalar x_j^α with $x_j^\alpha \text{id}_{V_j^\alpha} = (\widetilde{\text{ev}}_{V_j^\alpha} \otimes \text{id}_{V_j^\alpha})(\text{id}_{V_j^\alpha} \otimes p_j^\alpha \mu_\alpha) : V_j^\alpha \rightarrow V_j^\alpha$. Therefore $p_j^\alpha \mu_\alpha = x_j^\alpha \widetilde{\text{coev}}_{V_j^\alpha}$ and so, by using (3.48), $\mu_\alpha = \sum_{j \in J_\alpha} q_j^\alpha p_j^\alpha \mu_\alpha = \sum_{j \in J_\alpha} x_j^\alpha q_j^\alpha \widetilde{\text{coev}}_{V_j^\alpha}$.

Let $e = p_0^1 : B_1 \rightarrow \mathbb{1}$. By Lemma 3.12, e is a categorical right cointegral for B_1 . Using (3.48), we have

$$e \mu_1 = \sum_{j \in J_1} x_j^1 p_0^1 q_0^j \widetilde{\text{coev}}_{V_j^1} = x_0^1 \widetilde{\text{coev}}_{\mathbb{1}} = x_0^1.$$

Then, since the antipode of B is bijective (by Theorem 3.5(b)),

$$\begin{aligned} x_0^1 \text{id}_{(V_j^\alpha)^* \otimes V_j^\alpha} &= e \mu_1 p_j^\alpha q_j^\alpha \quad \text{by (3.48)} \\ &= e \mu_1 p_j^\alpha S_{\alpha^{-1}}^{-1} S_{\alpha^{-1}} q_j^\alpha \\ &= (p_j^\alpha \otimes e m_{\alpha, \alpha^{-1}})(\Delta_\alpha \mu_\alpha \otimes S_{\alpha^{-1}} q_j^\alpha) \quad \text{by Lemma 3.4(b)} \\ &= (\text{id}_{(V_j^\alpha)^* \otimes V_j^\alpha} \otimes e m_{\alpha, \alpha^{-1}})((p_j^\alpha \otimes \text{id}_{B_\alpha})\Delta_\alpha \mu_\alpha \otimes S_{\alpha^{-1}} q_j^\alpha). \end{aligned}$$

Now

$$\begin{aligned} (p_j^\alpha \otimes \text{id}_{B_\alpha})\Delta_\alpha \mu_\alpha &= \sum_{k \in J_\alpha} x_k^\alpha (p_j^\alpha \otimes \text{id}_{B_\alpha})\Delta_\alpha q_k^\alpha \widetilde{\text{coev}}_{V_k^\alpha} \\ &= \sum_{k \in J_\alpha} x_k^\alpha (p_j^\alpha q_k^\alpha \otimes q_k^\alpha)(\text{id}_{(V_k^\alpha)^*} \otimes \text{coev}_{V_k^\alpha} \otimes \text{id}_{V_k^\alpha}) \widetilde{\text{coev}}_{V_k^\alpha} \\ &= x_j^\alpha (\text{id}_{(V_j^\alpha)^* \otimes V_j^\alpha} \otimes q_j^\alpha)(\text{id}_{(V_j^\alpha)^*} \otimes \text{coev}_{V_j^\alpha} \otimes \text{id}_{V_j^\alpha}) \widetilde{\text{coev}}_{V_j^\alpha} \quad \text{by (3.48)}. \end{aligned}$$

Therefore

$$x_0^1 \text{id}_{(V_j^\alpha)^* \otimes V_j^\alpha} = x_j^\alpha (\text{id}_{(V_j^\alpha)^* \otimes V_j^\alpha} \otimes e m_{\alpha, \alpha^{-1}})((\text{id}_{(V_j^\alpha)^* \otimes V_j^\alpha} \otimes q_j^\alpha)(\text{id}_{(V_j^\alpha)^*} \otimes \text{coev}_{V_j^\alpha} \otimes \text{id}_{V_j^\alpha}) \widetilde{\text{coev}}_{V_j^\alpha} \otimes S_{\alpha^{-1}} q_j^\alpha)$$

and so

$$\begin{aligned}
 x_0^1 \dim_q(V_j^\alpha) \text{id}_{V_j^\alpha} &= x_0^1 \widetilde{\text{ev}}_{V_j^\alpha} \text{coev}_{V_j^\alpha} \text{id}_{V_j^\alpha} \quad \text{by (3.27)} \\
 &= (\widetilde{\text{ev}}_{V_j^\alpha} \otimes \text{id}_{V_j^\alpha})(\text{id}_{V_j^\alpha} \otimes x_0^1 \text{id}_{(V_j^\alpha)^* \otimes V_j^\alpha})(\text{coev}_{V_j^\alpha} \otimes \text{id}_{V_j^\alpha}) \\
 &= x_j^\alpha (\widetilde{\text{ev}}_{V_j^\alpha} \otimes \text{id}_{V_j^\alpha})(\text{id}_{V_j^\alpha \otimes (V_j^\alpha)^* \otimes V_j^\alpha} \otimes e m_{\alpha, \alpha^{-1}}) \\
 &\quad (\text{id}_{V_j^\alpha} \otimes (\text{id}_{(V_j^\alpha)^* \otimes V_j^\alpha} \otimes q_j^\alpha)(\text{id}_{(V_j^\alpha)^*} \otimes \text{coev}_{V_j^\alpha} \otimes \text{id}_{V_j^\alpha}) \widetilde{\text{coev}}_{V_j^\alpha} \otimes S_{\alpha^{-1}} q_j^\alpha) \\
 &\quad (\text{coev}_{V_j^\alpha} \otimes \text{id}_{V_j^\alpha}) \\
 &= e \eta x_j^\alpha \text{id}_{V_j^\alpha} \quad \text{by the equalities depicted in Figure 3.22.}
 \end{aligned}$$

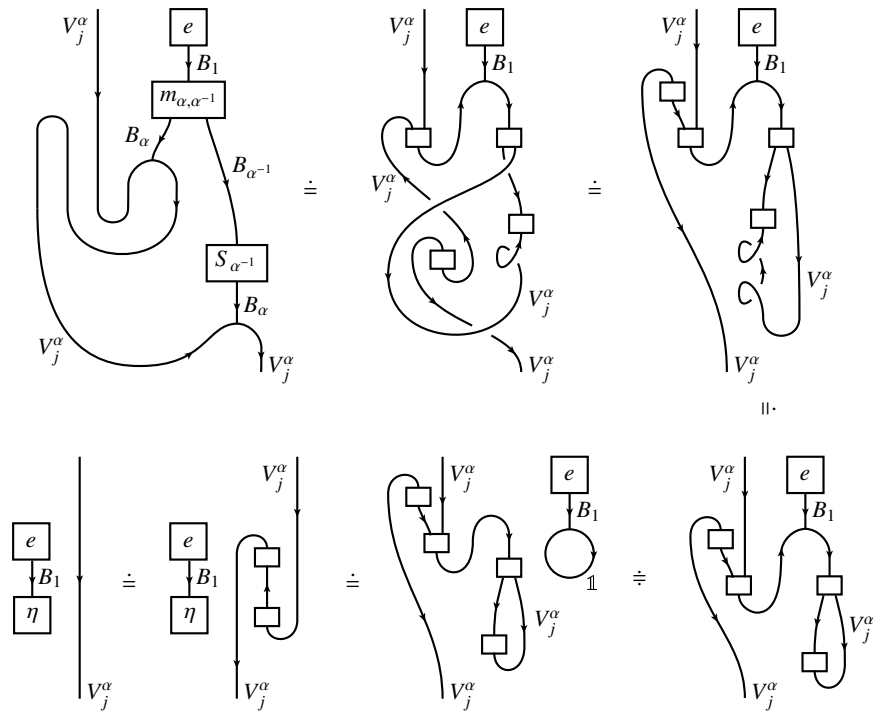

FIGURE 3.22.

Hence, since $e \eta = p_0^1 q_0^1 = \text{id}_\mathbb{1}$ by (3.48), we obtain that $x_j^\alpha = x_0^1 \dim_q(V_j^\alpha)$. The scalar $k = x_0^1$ is thus suitable. \square

CHAPTER 4

Hennings-like invariants of group-links and group-manifolds

In [12, 13], Hennings constructed invariants of links and 3-manifolds in terms of right integrals on certain Hopf algebras. Kauffman and Radford [17] clarified the relationships between these invariants and Hopf algebras and simplified Hennings' construction.

The purpose of this chapter is to give a method of defining, in a similar way of [17], an invariant of framed links in S^3 whose components are colored in some sense by the group π and then to normalize it to an invariant of principal π -bundles over 3-manifolds. The algebraic data which allows to do this are Hopf π -coalgebras, studied in Chapters 1 and 2.

Starting from a ribbon Hopf π -coalgebra $H = \{H_\alpha\}_{\alpha \in \pi}$ endowed with a π -trace $\text{tr} = (\text{tr}_\alpha)_{\alpha \in \pi}$, we give an improved version of the Kauffman-Radford method of [17] in order to construct an invariant $\text{Inv}_{\{H, \text{tr}\}}(L, g)$ of framed links L endowed with a group homomorphism $g : \pi_1(S^3 \setminus L) \rightarrow \pi$ (called π -links). This construction is made by coloring the vertical segments of a generic diagram of L with π via the homomorphism, by decorating the crossings with the R -matrix, by concentrating this algebraic decoration with the structure morphisms of H , and then by evaluating the result with the π -trace $\text{tr} = (\text{tr}_\alpha)_{\alpha \in \pi}$. We show that the Reidemeister moves colored in some sense by π report the equivalence of the pairs (L, g) , and we verify the invariance under these moves by using properties of quasitriangular and ribbon Hopf π -coalgebras and of their π -traces established in Chapter 2. We give examples of computations (by using Hopf π -coalgebras constructed from bicharacters of π) which shows that this invariant is not trivial.

When a π -trace constructed from a π -integral is used, the invariant $\text{Inv}_{\{H, \text{tr}^\dagger\}}$ may be normalized to an invariant $\tau_H(M, \xi)$ of principal π -bundles ξ over 3-manifolds M (called π -manifolds). This construction is made by presenting M by surgery along a framed link L , by defining $g : \pi_1(S^3 \setminus L) \rightarrow \pi$ by means of the monodromy of the π -bundle, and then by normalizing $\text{Inv}_{\{H, \text{tr}^\dagger\}}(L, g)$. We show that the Kirby moves colored in some sense by π report the equivalence of principal π -bundles over 3-manifolds, and we verify the invariance under these moves by using the properties of π -integrals and the fact that a π -trace constructed from a π -integral is used. This invariant is not trivial (we give an example of computation for some $\mathbb{Z}/n\mathbb{Z}$ -bundles over lens spaces, starting from the Hopf $\mathbb{Z}/n\mathbb{Z}$ -coalgebras of [34]) and coincides with the Hennings' one when $\pi = 1$.

In general, this invariant is different from that of Turaev [48]. We show that they agree if we start from a ribbon Hopf π -coalgebra such that its category of representations is modular. The technique employed to prove this result uses the categorical Hopf π -algebras, studied in Chapter 3, which allows us to relate the categorical approach of [48] with the algebraic one developed here. In particular, we rewrite the Turaev invariant in terms of π -integrals of a categorical Hopf π -algebra.

Finally, we show that the invariant τ_H extends to a homotopy quantum field theory in dimension $2 + 1$ (for connected cobordisms between connected surfaces) with target the Eilenberg-Mac Lane space $K(\pi, 1)$, that is, a topological quantum field theory for (connected) surfaces and (connected) cobordisms endowed with a homotopy class of maps to $K(\pi, 1)$.

This chapter is organized as follows. In Section 4.1, we construct an invariant of π -links. In Section 4.2, we normalize it to an invariant of π -manifolds. In Section 4.3, we compare this invariant of π -manifolds with that of Turaev. Finally, in Section 4.4, we show that our invariant of π -manifolds extends to a homotopy quantum field theory in dimension $2 + 1$.

4.1. Invariants of π -links

In this section, we generalize the Kauffman-Radford method to construct Hennings-like invariants of framed links endowed with a morphism from their fundamental group to π , by using a ribbon Hopf π -coalgebra.

4.1.1. π -links. Following [48], a π -link in S^3 is a triple (L, z, g) where L is a framed link in S^3 , $z \in S^3 \setminus L$ (the *base point*), and $g : \pi_1(S^3 \setminus L, z) \rightarrow \pi$ is a group homomorphism. Recall that a link $L = L_1 \cup \dots \cup L_m$ is *framed* if each of its components L_i is provided with a *longitude* $\tilde{L}_i \subset S^3 \setminus L$ which goes very closely along L_i (or equivalently with an integer n_i , called *framing number*, which is related to \tilde{L}_i by $n_i = \text{lk}(\tilde{L}_i, L_i)$ where a parallel orientation for L_i and \tilde{L}_i is chosen). The framing of a framed link L will be denoted by $\tilde{L} = \tilde{L}_1 \cup \dots \cup \tilde{L}_m$.

Two π -links (L, z, g) and (L', z', g') are said to be *equivalent* if there exists an orientation-preserving homeomorphism $h : S^3 \rightarrow S^3$ such that $h(L) = L'$, $h(\tilde{L}) = \tilde{L}'$, $h(z) = z'$, and $g' \circ h_* = g$ where $h_* : \pi_1(S^3 \setminus L, z) \rightarrow \pi_1(S^3 \setminus L', z')$ is the group isomorphism induced by h in homotopy.

4.1.2. π -colored link diagrams. By a *generic diagram* of a framed link we shall mean a diagram of the link, arranged with respect to a vertical direction and with blackboard framing, such that the only critical points of the height function are crossings and extrema and the height function is non-degenerate in all extremal points (i.e., in a neighborhood of any extremal point, the diagram looks like a cap or a cup). The segments of a generic diagram delimited by extremal points and under-crossings are called the *vertical segments* of the diagram.

A π -colored link diagram is a generic diagram of a framed link such that each of its vertical segments is provided with an element of π , called the *color* of the vertical segment, in such a way that for crossings and extrema the colors are related as in Figure 4.1.

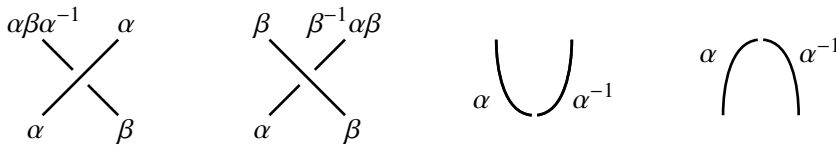

FIGURE 4.1.

Two π -colored link diagrams are said to be *equivalent* if one can be obtained from the other by a finite sequence of isotopies (in the class of generic link diagrams) which preserve the colors of the vertical segments and of moves of Figure 4.2.

Note that π -colored link diagrams can be associated to a π -link (L, z, g) by the following procedure: regularly project the framed link L onto a plane from the base point, i.e., consider a generic diagram of L such that the base point z corresponds to the eyes of the reader. Color then the vertical segments in the following way: a vertical segment is colored by $\alpha = g([\mu]) \in \pi$ where μ represents a loop that, starting from the base point z (the eyes of the reader) above the diagram, goes straight to the segment, encircles it from left to right (i.e., in such a way that its linking number

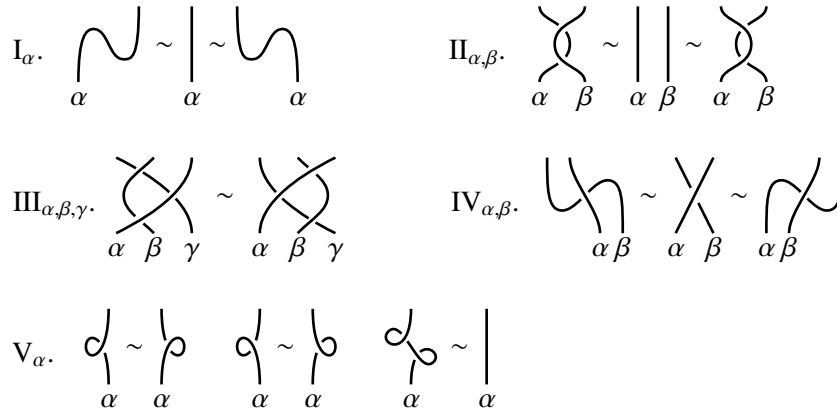

FIGURE 4.2. Equivalence moves for π -colored link diagrams

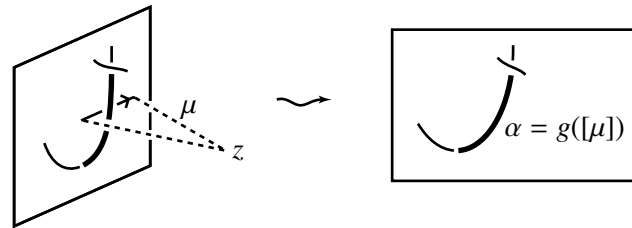

FIGURE 4.3. Coloration of diagrams of π -links

with the segment oriented downwards is 1), and returns immediately to the base point as shown in Figure 4.3.

Reciprocally, using the Wirtinger presentation of knot groups (see, e.g., [27]), one easily verifies that a π -colored link diagram determines (up to equivalence) a unique π -link. Moreover the operations defining the equivalence of π -colored link diagrams can be realized by an ambient isotopy and thus by an equivalence between the π -links they determine. Hence equivalent π -colored link diagrams define equivalent π -links. We show in the next lemma that the converse is also true.

LEMMA 4.1. *Two π -links are equivalent if and only if all their π -colored link diagrams are equivalent.*

Proof. Let us first verify that two π -colored diagrams D and D' of a same π -link (L, z, g) are equivalent. Let p and p' be two directed projections which leads to D and D' respectively. Think of the set of directed projection as points on a unit sphere $S^2 \subset S^3$, centered in the base point z , endowed with the induced topology. A standard argument (general position) shows that singular projections (those that not lead to generic diagrams) are represented on S^2 by a finite number of curves (see [6]). Then choose on S^2 a path s from p to p' in general position with respect to the curves of singular projections. When such a curve is crossed, the π -colored link diagram will be changed by a move $I_\alpha, \dots, V_\alpha$, depending on the type of singularity corresponding to the singular curve that is, crossed. Moreover parts of s between the singular curves correspond to isotopies (in the class of generic link diagrams) which preserve the colors of the vertical segments.

It remains to show that for a fixed projection, the π -colored diagrams obtained from two equivalent π -links are equivalent. Let (L, z, g) and (L', z', g') be two equivalent π -links and fix a directed

projection onto a plane P which leads to generic diagrams of L and L' . Since (L, z, g) and (L', z', g') are equivalent, there exists an orientation-preserving homeomorphism $h : S^3 \rightarrow S^3$ such that $h(L) = L'$, $h(\widetilde{L}) = \widetilde{L}'$, $h(z) = z'$, and $g' \circ h_* = g$. Since h is an orientation-preserving homeomorphism of S^3 , it is isotopic to the identity, i.e., there exists a family $(h_t)_{t \in [0,1]}$ of homeomorphisms of S^3 such that $h_0 = \text{id}_{S^3}$ and $h_1 = h$. By translating the plane P (with respect to the direction of the projection), we can assume that all the $h_t(z)$ remains in the same half-space delimited by P and, by general position argument, we can suppose that the projection onto P of the framed link $h_t(L)$ is a generic diagram for all but a finite number of $t \in [0, 1]$ which correspond to Reidemeister moves for framed links. Using this finite sequence of transformations and the coloring homomorphisms $g \circ (h_t^{-1})_* : \pi_1(h_t(L), h_t(z)) \rightarrow \pi$, one easily deduces that the π -colored diagrams obtained by projecting (L, z, g) and (L', z', g') onto P are equivalent. \square

4.1.3. π -links compatible with a crossed Hopf π -coalgebra. Let $H = \{H_\alpha\}_{\alpha \in \pi}$ be a crossed Hopf π -coalgebra with crossing φ . A π -link (L, z, g) is said to be *compatible with H* or, shortly, *H -compatible* if, for any component C of L , for any path $\gamma : [0, 1] \rightarrow S^3 \setminus L$ connecting the base point $z \in S^3 \setminus L$ to a point $\gamma(1) \in \widetilde{C}$, and for any orientation ν of \widetilde{C} , the following conditions are satisfied:

$$(4.1) \quad g(\lambda_{(\gamma, \nu)}) \text{ belongs to the center } Z(\pi) \text{ of } \pi;$$

$$(4.2) \quad \varphi_{g(\lambda_{(\gamma, \nu)})|H_\beta} = \text{id}_{H_\beta} \text{ for all } \beta \in \pi;$$

where $\lambda_{(\gamma, \nu)} = [\gamma^{-1}\widetilde{C}\gamma] \in \pi_1(S^3 \setminus L, z)$ is the homotopy class of the loop $\gamma^{-1}\widetilde{C}\gamma$ (here the oriented circle \widetilde{C} is viewed as a loop based on the point $\gamma(1)$).

LEMMA 4.2. *Let $H = \{H_\alpha\}_{\alpha \in \pi}$ be a crossed Hopf π -coalgebra and (L, z, g) be a π -link.*

- (a) *If, for any component C of L , there exist a path $\gamma : [0, 1] \rightarrow S^3 \setminus L$ connecting the base point $z \in S^3 \setminus L$ to a point $\gamma(1) \in \widetilde{C}$ and an orientation ν of \widetilde{C} such that (4.1) and (4.2) hold, then (L, z, g) is H -compatible.*
- (b) *If (L, z, g) is H -compatible and if ρ is a homeomorphism of S^3 (preserving or reversing the orientation), then the π -link $(\rho(L), \rho(z), g \circ \rho_*^{-1})$ is H -compatible. In particular H -compatibility is preserved under equivalence of π -links.*
- (c) *(L, z, g) is H -compatible if and only if it is H^{cop} -compatible, where H^{cop} is the crossed Hopf π -coalgebra coopposite to H .*

Proof. Let us show Part (a). Suppose first that the opposite orientation $-\nu$ for \widetilde{C} is chosen. Then $\lambda_{(\gamma, -\nu)} = \lambda_{(\gamma, \nu)}^{-1}$ and so $\lambda_{(\gamma, -\nu)} \in Z(\pi)$ and $\varphi_{g(\lambda_{(\gamma, -\nu)})} = \varphi_{g(\lambda_{(\gamma, \nu)}^{-1})} = \text{id}$ (by Lemma 2.1). Suppose secondly that γ' is another path in $S^3 \setminus L$ connecting the base point z to \widetilde{C} . Then there exists a loop ℓ in $S^3 \setminus L$ based on z such that γ' is homotopic to $\gamma\ell$ in $(S^3 \setminus L, z)$. Set $\xi = [\ell] \in \pi_1(S^3 \setminus L, z)$. We have that $\lambda_{(\gamma', \nu)} = [\gamma'^{-1}\widetilde{C}\gamma'] = [\ell^{-1}\gamma^{-1}\widetilde{C}\gamma\ell] = \xi^{-1}\lambda_{(\gamma, \nu)}\xi$ and so

$$g(\lambda_{(\gamma', \nu)}) = g(\xi^{-1}\lambda_{(\gamma, \nu)}\xi) = g(\xi)^{-1}g(\lambda_{(\gamma, \nu)})g(\xi) = g(\xi)^{-1}g(\xi)g(\lambda_{(\gamma, \nu)}) = g(\lambda_{(\gamma, \nu)}).$$

Hence $g(\lambda_{(\gamma', \nu)}) \in Z(\pi)$ and $\varphi_{g(\lambda_{(\gamma', \nu)})} = \varphi_{g(\lambda_{(\gamma, \nu)})} = \text{id}$.

To show Part (b), fix a component C of L . Let $\gamma : [0, 1] \rightarrow S^3 \setminus L$ be a path connecting the base point $\rho(z) \in S^3 \setminus \rho(L)$ to a point $\gamma(1) \in \rho(\widetilde{C}) = \rho(\widetilde{C})$ and ν be an orientation of $\rho(\widetilde{C})$. Then

$$\lambda_{(\gamma, \nu)} = [\gamma^{-1}\rho(\widetilde{C})\gamma] = \rho_*[\rho^{-1}(\gamma)\widetilde{C}\rho^{-1}(\gamma)] = \rho_*(\lambda_{(\rho^{-1}(\gamma), \rho^{-1}(\nu))}),$$

where $\rho^{-1}(\nu)$ is the orientation of \widetilde{C} induced by ρ^{-1} from the orientation ν of $\rho(\widetilde{C})$. Therefore we have that $(g \circ \rho_*^{-1})(\lambda_{(\gamma, \nu)}) = g(\lambda_{(\rho^{-1}(\gamma), \rho^{-1}(\nu))})$. Hence (4.1) and (4.2) are satisfied since (L, z, g) is H -compatible.

Part (c) follows directly from the fact that $\varphi_{\alpha|H_\beta}^{\text{cop}} = \varphi_{\alpha|H_{\beta^{-1}}}$ for all $\alpha, \beta \in \pi$. \square

4.1.4. Invariants of π -links. Fix a ribbon Hopf π -coalgebra $H = (\{H_\alpha\}, \Delta, \varepsilon, S, \varphi, R, \theta)$ with bijective antipode, endowed with a π -trace $\text{tr} = (\text{tr}_\alpha)_{\alpha \in \pi}$. We now give a method to define an invariant of H -compatible π -links, which generalizes that of Kauffman-Radford [17] for computing Hennings' invariants.

Let $(L = L_1 \cup \dots \cup L_m, z, g)$ be a H -compatible π -link.

(A). Present the π -link (L, z, g) by a π -colored link diagram (as explained in Section 4.1.2).

(B). Each crossing of the π -colored link diagram is decorated with elements of the Hopf π -coalgebra $H = \{H_\alpha\}_{\alpha \in \pi}$ and with discs labelled by elements of π (which represent the action of φ) as shown in Figure 4.4, where $R_{\alpha, \beta} = a_\alpha \otimes b_\beta$ and $R_{\beta^{-1}, \alpha} = c_{\beta^{-1}} \otimes d_\alpha$. Recall that it is implicit in this formalism that there is a summation over all the pairs a_α, b_β and $S_{\beta^{-1}}(c_{\beta^{-1}}), d_\alpha$. The diagram obtained after this step is called the *flat diagram of L* . Note that the flat diagram of L is composed by m closed plane curves (possibly endowed with labelled discs), each of them arising from a component of L . These closed plane curves are called the *components* of the flat diagram of L . The component of the flat diagram of L arising from the component L_i of L is called the *flat diagram of L_i* . The *algebraic decoration* of the flat diagram of L consists in the points decorated by elements of H .

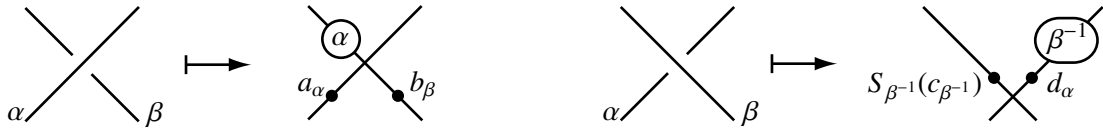

FIGURE 4.4. Algebraization of a π -colored link diagram

(C). On each component of the flat diagram of L , the algebraic decoration is concentrated in a point other than extrema and labelled discs, according to the rules of Figure 4.5, where $\alpha, \beta \in \pi$ and $a, b \in H_\alpha$.

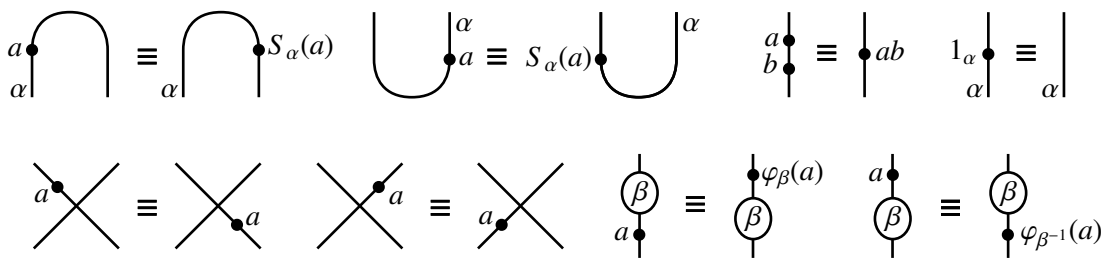
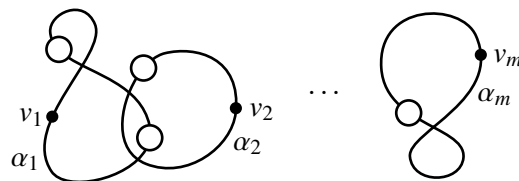

FIGURE 4.5. Rules for concentrating the algebraic decoration

In that way we get elements $v_1 \in H_{\alpha_1}, \dots, v_m \in H_{\alpha_m}$:



Note that $v_i = 1_{\alpha_i}$ if the flat diagram of L_i is free of algebraic decoration.

(D). For $1 \leq i \leq m$, let d_i be the Whitney degree of the flat diagram of L_i obtained by traversing it upwards from the vertical segment where the algebraic decoration have been concentrated. The Whitney degree is the total turn of the tangent vector to the curve when one traverses it in the given direction. For example:

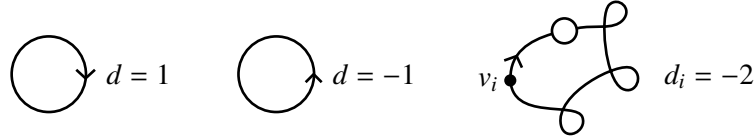

Finally set

$$\text{Inv}_{\{H, \text{tr}\}}(L, z, g) = \text{tr}_{\alpha_1}(G_{\alpha_1}^{d_1} v_1) \cdots \text{tr}_{\alpha_m}(G_{\alpha_m}^{d_m} v_m),$$

where $G = (G_\alpha)_{\alpha \in \pi}$ is the spherical π -grouplike element of H .

Recall that H -compatibility is preserved under equivalence of π -links (see Lemma 4.2(b)).

THEOREM 4.3. *Let $H = \{H_\alpha\}_{\alpha \in \pi}$ be a ribbon Hopf π -coalgebra with bijective antipode, endowed with a π -trace $\text{tr} = (\text{tr}_\alpha)_{\alpha \in \pi}$. Then $\text{Inv}_{\{H, \text{tr}\}}$ is an invariant of H -compatible π -links.*

The theorem is proven in the next subsection.

This invariant is not trivial (we give explicit computations in Examples 4.8 and 4.9).

When $\pi = 1$, $\text{Inv}_{\{H, \text{tr}\}}$ equals the Hennings' invariant of framed links (in the Kauffman-Radford formulation of [17]) calculated from the ribbon Hopf algebra H_1^{op} (endowed with the R -matrix $R_{1,1}^{-1}$ and the twist θ_1^{-1}) and the trace tr_1 .

4.1.5. Proof of Theorem 4.3. We first remark that, when concentrating the algebraic decoration as explained in Step (B), we can identify the curls, in a compatible way with normalization of the invariant by the Whitney degree, as in Figure 4.6.



FIGURE 4.6. Identification of the curls

Indeed, since $S_{\alpha^{-1}} S_\alpha(x) = G_\alpha x G_\alpha^{-1}$ for all $\alpha \in \pi$ and $x \in H_\alpha$ (by Lemma 2.9), the identification is justified by:

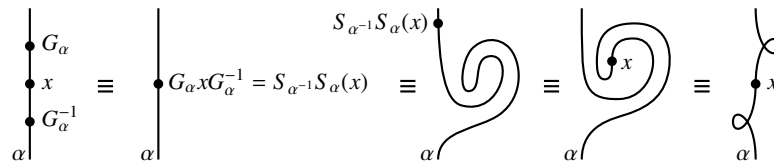

Moreover, since $\varphi_\alpha \varphi_\beta = \varphi_{\alpha\beta}$ by (2.4), $\varphi_1|_{H_\alpha} = \text{id}_{H_\alpha}$ by Lemma 2.1(a), $\varphi_\beta S_\alpha = S_{\beta\alpha\beta^{-1}} \varphi_\beta$ by Lemma 2.1(c), and an element $a \in H_\alpha$ is replaced by $\varphi_\beta(a)$ (resp. $\varphi_{\beta^{-1}}(a)$) when it crosses upwards (resp. downwards) a disc labelled by β (see Figure 4.5), the labelled discs can be moved, gathered, or collapsed as in Figure 4.7.

To demonstrate Theorem 4.3, we have to show that:

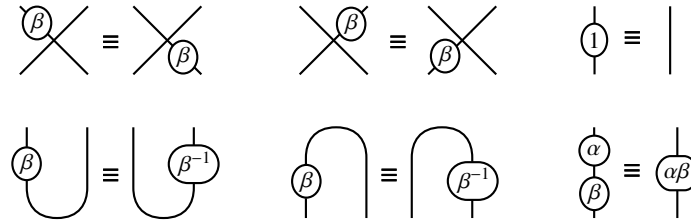

FIGURE 4.7. Rules for concentrating labelled discs

- (i) for a given π -colored diagram of a π -link, the scalar obtained by performing Steps (B), (C), and (D) is well-defined (that is, independent of the manner of applying the these steps);
- (ii) the scalar $\text{Inv}_{\{H, \text{tr}\}}(L, z, g)$ does not depend on the choice of a π -colored diagram for the π -link (L, z, g) ;
- (iii) two equivalent π -links give rise to the same scalar.

PROOF OF (i). Consider a π -colored diagram of a π -link $(L = \cup_{i=1}^m L_i, z, g)$ and apply Step (B) (note that there is only one way to apply it). Recall that the obtained diagram is called the flat diagram of L . Fix $1 \leq i \leq m$ and choose a point p_i on the flat diagram of L_i other than extrema, labelled discs, and points decorated by algebraic elements. Denote by α_i the color of the (vertical) segment of p_i and by d_i the Whitney degree of the flat diagram of L_i obtained by traversing it upwards from p_i . Let $v_i \in H_{\alpha_i}$ be a result of concentrating the algebraic decoration on p_i . We have to verify that the scalar $\text{tr}_{\alpha_i}(G_{\alpha_i}^{d_i} v_i)$ is independent of the manner of concentrating the algebraic decoration on the point p_i and that it does not depend on the choice of the point p_i .

To show that the scalar $\text{tr}_{\alpha_i}(G_{\alpha_i}^{d_i} v_i)$ is independent of the manner of concentrating the algebraic decoration on the point p_i , we choose another point q_i on the flat diagram of L_i (other than extrema, labelled discs, and points decorated by algebraic elements). The couple of points (p_i, q_i) divides the flat diagram of L_i into two arcs. Following the rules of Figure 4.5 and since the H_β are associative, the φ_β are isomorphisms of algebras, and the S_β are anti-isomorphisms of algebras, there is a unique manner to concentrate the algebraic decoration of each arc on a point located just above p_i (resp. below p_i). We denote by $t(q_i) \in H_{\alpha_i}$ (resp. $b(q_i) \in H_{\alpha_i}$) the result of these concentrations, see Figure 4.8.

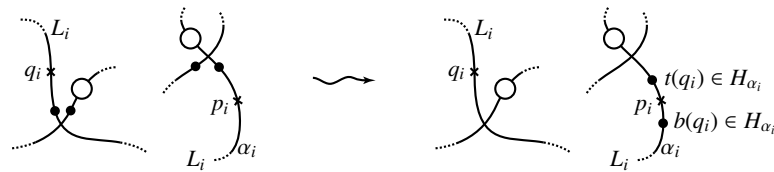

FIGURE 4.8.

To show that the scalar $\text{tr}_{\alpha_i}(G_{\alpha_i}^{d_i} v_i)$ is independent of the manner of concentrating the algebraic decoration on the point p_i amounts then to verify that $\text{tr}_{\alpha_i}(G_{\alpha_i}^{d_i} v(q_i))$ does not depend on the choice of the point q_i , where $v(q_i) = t(q_i)b(q_i)$.

If q_i moves through an arc of the flat diagram for L_i which does not contain any algebraic decoration, then $t(q_i)$ and $b(q_i)$ clearly remain unchanged and thus $\text{tr}_{\alpha_i}(G_{\alpha_i}^{d_i} v(q_i))$ also.

Suppose that q_i goes through a point decorated by some element $a \in H_\delta$ (for some $\delta \in \pi$). Consider two points q_i and q'_i located respectively above and below the point decorated by a (see Figure 4.9). Let \mathcal{A} (resp. \mathcal{A}') be the arc of the flat diagram of L_i delimited by q_i and p_i (resp. q'_i and p_i) which does not contain the point q'_i (resp. q_i). As above there is a unique manner to concentrate the algebraic decoration of the arcs \mathcal{A} and \mathcal{A}' on two points located just above and below p_i (see Figure 4.9). Moreover, using the rules of Figure 4.7, there is a unique way to collapse the labelled discs of the arc \mathcal{A} (resp. \mathcal{A}') into a unique labelled disc located above q_i (resp. below q'_i). Denote by $\alpha \in \pi$ (resp. $\alpha' \in \pi$) the label of this disc (see Figure 4.9).

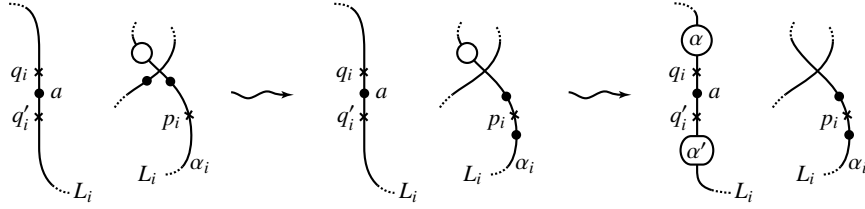

FIGURE 4.9.

LEMMA 4.4. $\varphi_{\alpha'^{-1}} = \varphi_\alpha$.

Proof. Consider the initial flat diagram of L_i (i.e., the one obtained just after applying Step (B)) and traverse it downwards from q_i . Starting with $\gamma = 1 \in \pi$, each time a disc labelled by some $\beta \in \pi$ is encountered, replace γ by $\gamma\beta^\nu$, where $\nu = 1$ (resp. $\nu = -1$) if the labelled disc is traversed downwards (resp. upwards). By this procedure, after a complete turn around the flat diagram of L_i , we obtain an element $\gamma_{\text{end}} \in \pi$. Now each labelled disc of the flat diagram for L_i comes from a crossing of the diagram of L , see Step (B). Thus $\gamma \leftarrow \gamma\beta$ results from the situation depicted in Figure 4.10(a) and $\gamma \leftarrow \gamma\beta^{-1}$ results from the situation depicted in Figure 4.10(b). Therefore (recall that L is arranged with blackboard framing) the result γ_{end} is the image under g of the (homotopy) longitude \bar{L}_i (which is here oriented downwards from q_i). Since the π -link (L, z, g) is H -compatible, we have that $\gamma_{\text{end}} \in Z(\pi)$ and $\varphi_{\gamma_{\text{end}}} = \text{id}$. Moreover the steps $\gamma \leftarrow \gamma\beta$ and $\gamma \leftarrow \gamma\beta^{-1}$ are clearly compatible with the rules of Figure 4.7 and so $\gamma_{\text{end}} = \alpha'\alpha$. Therefore $\varphi_{\alpha'^{-1}}\varphi_\alpha = \varphi_{\alpha'\alpha} = \varphi_{\alpha'\alpha} = \varphi_{\gamma_{\text{end}}} = \text{id}$ by (2.4) and Lemma 2.1. Hence $\varphi_{\alpha'^{-1}} = \varphi_\alpha$. \square

Finally there is two cases to consider: the algebraic decoration concentrated just above p_i can arise from either the arc \mathcal{A} or the arc \mathcal{A}' , see Figure 4.11.

In Case I, there exists $k \in \mathbb{Z}$ (resp. $l \in \mathbb{Z}$) such that $k + \frac{1}{2}$ (resp. $l + \frac{1}{2}$) is the Whitney degree of the arc \mathcal{A} oriented upwards from q_i (resp. the arc \mathcal{A}' oriented downwards from q'_i), that is, half of the number of half-turns of the tangent vector to the curve as one traverses it in the given direction (with the sign convention $\curvearrowright = +\frac{1}{2}$ and $\curvearrowleft = -\frac{1}{2}$). In this setting we have that $d_i = -(k + \frac{1}{2}) + (l + \frac{1}{2}) = -k + l$. Then, using Lemmas 2.9(f) and 4.4, we obtain

$$(4.3) \quad t(q'_i) = (S_{\alpha_i^{-1}} S_{\alpha_i})^k S_{\alpha_i^{-1}}(\varphi_\alpha(a))t(q_i) = G_{\alpha_i}^k S_{\alpha_i^{-1}}(\varphi_\alpha(a))G_{\alpha_i}^{-k} \cdot t(q_i)$$

and

$$(4.4) \quad b(q_i) = b(q'_i)(S_{\alpha_i^{-1}} S_{\alpha_i})^l S_{\alpha_i^{-1}}(\varphi_{\alpha'^{-1}}(a)) = b(q'_i)G_{\alpha_i}^l S_{\alpha_i^{-1}}(\varphi_\alpha(a))G_{\alpha_i}^{-l}.$$

Therefore

$$\begin{aligned} \text{tr}_{\alpha_i}(G_{\alpha_i}^{d_i} v(q'_i)) &= \text{tr}_{\alpha_i}(G_{\alpha_i}^{d_i} t(q'_i) b(q'_i)) \\ &= \text{tr}_{\alpha_i}(G_{\alpha_i}^{d_i} G_{\alpha_i}^k S_{\alpha_i^{-1}}(\varphi_\alpha(a)) G_{\alpha_i}^{-k} t(q_i) b(q'_i)) \quad \text{by (4.3)} \end{aligned}$$

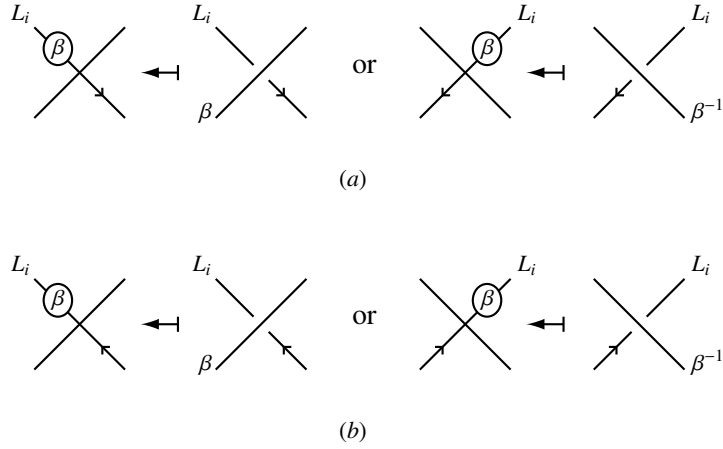

FIGURE 4.10.

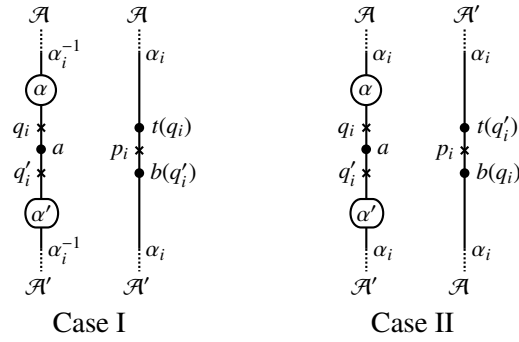

FIGURE 4.11.

$$\begin{aligned}
 &= \text{tr}_{\alpha_i}(G_{\alpha_i}^l S_{\alpha_i^{-1}}(\varphi_{\alpha}(a)) G_{\alpha_i}^{-l} G_{\alpha_i}^{d_i} t(q_i) b(q'_i)) \quad \text{since } d_i = -k + l \\
 &= \text{tr}_{\alpha_i}(G_{\alpha_i}^{d_i} t(q_i) b(q'_i) G_{\alpha_i}^l S_{\alpha_i^{-1}}(\varphi_{\alpha}(a)) G_{\alpha_i}^{-l}) \quad \text{by (2.17)} \\
 &= \text{tr}_{\alpha_i}(G_{\alpha_i}^{d_i} t(q_i) b(q_i)) \quad \text{by (4.4)} \\
 &= \text{tr}_{\alpha_i}(G_{\alpha_i}^{d_i} v(q_i)).
 \end{aligned}$$

In Case II, there exists $k \in \mathbb{Z}$ (resp. $l \in \mathbb{Z}$) such that k (resp. l) is the Whitney degree of the arc \mathcal{A} oriented upwards from q_i (resp. \mathcal{A}' oriented downwards from q'_i). Then $d_i = k - l$ and, using Lemmas 2.9(f) and 4.4, we obtain that

$$(4.5) \quad t(q_i) = (S_{\alpha_i^{-1}} S_{\alpha_i})^l (\varphi_{\alpha^{-1}}(a)) t(q'_i) = G_{\alpha_i}^l \varphi_{\alpha}(a) G_{\alpha_i}^{-l} t(q'_i)$$

and

$$(4.6) \quad b(q'_i) = b(q_i) (S_{\alpha_i^{-1}} S_{\alpha_i})^k (\varphi_{\alpha}(a)) = b(q_i) G_{\alpha_i}^k \varphi_{\alpha}(a) G_{\alpha_i}^{-k}.$$

Therefore

$$\text{tr}_{\alpha_i}(G_{\alpha_i}^{d_i} v(q'_i)) = \text{tr}_{\alpha_i}(G_{\alpha_i}^{d_i} t(q'_i) b(q'_i))$$

$$\begin{aligned}
&= \operatorname{tr}_{\alpha_i}(G_{\alpha_i}^{d_i} t(q'_i) b(q_i) G_{\alpha_i}^k \varphi_{\alpha}(a) G_{\alpha_i}^{-k}) \quad \text{by (4.6)} \\
&= \operatorname{tr}_{\alpha_i}(G_{\alpha_i}^k \varphi_{\alpha}(a) G_{\alpha_i}^{-k} G_{\alpha_i}^{d_i} t(q'_i) b(q_i)) \quad \text{by (2.17)} \\
&= \operatorname{tr}_{\alpha_i}(G_{\alpha_i}^{d_i} G_{\alpha_i}^l \varphi_{\alpha}(a) G_{\alpha_i}^{-l} t(q'_i) b(q_i)) \quad \text{since } d_i = k - l \\
&= \operatorname{tr}_{\alpha_i}(G_{\alpha_i}^{d_i} t(q_i) b(q_i)) \quad \text{by (4.3)} \\
&= \operatorname{tr}_{\alpha_i}(G_{\alpha_i}^{d_i} v(q_i)).
\end{aligned}$$

In every case, we get that $\operatorname{tr}_{\alpha_i}(G_{\alpha_i}^{d_i} v(q'_i)) = \operatorname{tr}_{\alpha_i}(G_{\alpha_i}^{d_i} v(q_i))$. The scalar $\operatorname{tr}_{\alpha_i}(G_{\alpha_i}^{d_i} v_i)$ is hence independent of the manner of concentrating the algebraic decoration on p_i .

Let us show that $\operatorname{tr}_{\alpha_i}(G_{\alpha_i}^{d_i} v_i)$ does not depend on the choice of the point p_i . Firstly, if we move p_i across an extremum, then the color α_i is replaced by α_i^{-1} , the element v_i is replaced by $S_{\alpha_i}^{\nu}(v_i)$, where $\nu = +1$ if we move the point p_i across a maximum from left to right or across a minimum from right to left and $\nu = -1$ otherwise, and the Whitney degree d_i is replaced by $-d_i$. Now

$$\begin{aligned}
\operatorname{tr}_{\alpha_i^{-1}}(G_{\alpha_i^{-1}}^{-d_i} S_{\alpha_i}^{\nu}(v_i)) &= \operatorname{tr}_{\alpha_i^{-1}}(S_{\alpha_i}^{\nu}(G_{\alpha_i}^{d_i} S_{\alpha_i}^{\nu}(v_i))) \quad \text{by Lemma 2.9(c)} \\
&= \operatorname{tr}_{\alpha_i^{-1}}(S_{\alpha_i}^{\nu}(v_i) G_{\alpha_i}^{d_i}) \quad \text{by Lemma 1.1(a)} \\
&= \operatorname{tr}_{\alpha_i}(v_i G_{\alpha_i}^{d_i}) \quad \text{by (2.18)} \\
&= \operatorname{tr}_{\alpha_i}(G_{\alpha_i}^{d_i} v_i) \quad \text{by (2.17)}.
\end{aligned}$$

Thus $\operatorname{tr}_{\alpha_i}(G_{\alpha_i}^{d_i} v_i)$ remains unchanged by moving p_i across an extremum.

Secondly, if we move p_i through a disc labelled by β , then the color α_i is replaced by $\beta^{\nu} \alpha_i \beta^{-\nu}$, where $\nu = +1$ (resp. $\nu = -1$) if we move the point p_i upwards (resp. downwards) through the labelled disc, the element v_i is replaced by $\varphi_{\beta^{\nu}}(v_i)$, and the Whitney degree d_i remains unchanged. Now

$$\begin{aligned}
\operatorname{tr}_{\beta^{\nu} \alpha_i \beta^{-\nu}}(G_{\beta^{\nu} \alpha_i \beta^{-\nu}}^{d_i} \varphi_{\beta^{\nu}}(v_i)) &= \operatorname{tr}_{\beta^{\nu} \alpha_i \beta^{-\nu}}(\varphi_{\beta^{\nu}}(G_{\alpha_i}^{d_i} \varphi_{\beta^{\nu}}(v_i))) \quad \text{by Lemma 2.9} \\
&= \operatorname{tr}_{\beta^{\nu} \alpha_i \beta^{-\nu}}(\varphi_{\beta^{\nu}}(G_{\alpha_i}^{d_i} v_i)) \quad \text{by (2.1)} \\
&= \operatorname{tr}_{\alpha_i}(G_{\alpha_i}^{d_i} v_i) \quad \text{by (2.19)}.
\end{aligned}$$

Therefore $\operatorname{tr}_{\alpha_i}(G_{\alpha_i}^{d_i} v_i)$ remains unchanged by moving p_i through a labelled disc. The scalar $\operatorname{tr}_{\alpha_i}(G_{\alpha_i}^{d_i} v_i)$ is hence independent of the choice of the point p_i on the flat diagram of L_i .

PROOF OF (II) AND (III). By Lemma 4.1, it suffices to verify that if we apply Steps (B), (C), and (D) to two equivalent π -colored link diagrams (which represent H -compatible π -links), then we get the same scalar. Recall that two π -colored link diagrams are equivalent if one can be obtained from the other by a finite sequence of isotopies which preserve the colors of the vertical segments and of moves I_{α} - V_{α} of Figure 4.2.

It is straightforward that $\operatorname{Inv}_{\{H, \operatorname{tr}\}}$ remains unchanged under isotopies (in the class of generic link diagrams) which preserve the colors of the vertical segments and under the move I_{α} .

To show the invariance under the move $\Pi_{\alpha, \beta}$, write $R_{\alpha, \beta} = m_{\alpha} \otimes n_{\beta}$ and $R_{\alpha^{-1}, \alpha \beta \alpha^{-1}} = r_{\alpha^{-1}} \otimes t_{\alpha \beta \alpha^{-1}}$. We have that

$$\begin{aligned}
&S_{\alpha^{-1}}(r_{\alpha^{-1}}) m_{\alpha} \otimes \varphi_{\alpha^{-1}}(t_{\alpha \beta \alpha^{-1}}) n_{\beta} \\
&= (S_{\alpha^{-1}} \otimes \operatorname{id}_{H_{\beta}})(\operatorname{id}_{H_{\alpha^{-1}}} \otimes \varphi_{\alpha^{-1}})(R_{\alpha^{-1}, \alpha \beta \alpha^{-1}}) \cdot R_{\alpha, \beta} \\
&= (S_{\alpha^{-1}} \otimes \operatorname{id}_{H_{\beta}})(\varphi_{\alpha} \otimes \operatorname{id}_{H_{\beta}})(R_{\alpha^{-1}, \beta}) \cdot R_{\alpha, \beta} \quad \text{by Lemma 2.1 and (2.7)} \\
&= R_{\alpha, \beta}^{-1} \cdot R_{\alpha, \beta} \quad \text{by Lemma 2.4(b)}
\end{aligned}$$

$$= 1_\alpha \otimes 1_\beta.$$

Therefore:

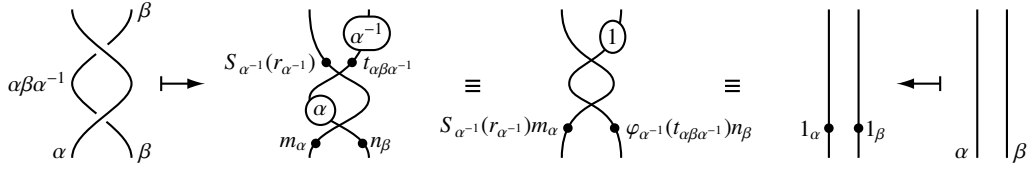

Here the symbol “ \equiv ” means that the flat diagrams are related by a finite sequence of isotopies (in the class of generic flat diagrams) and of moves of Figures 4.5, 4.6, and 4.7. The invariance under the first equivalence of $\Pi_{\alpha, \beta}$ is then verified. For the second one, this can be done similarly.

To show the invariance under the move $\text{III}_{\alpha, \beta, \gamma}$, write $R_{\alpha, \beta} = a_\alpha \otimes b_\beta$, $R_{\beta, \gamma} = m_\beta \otimes n_\gamma$, and $R_{\alpha, \gamma} = r_\alpha \otimes t_\gamma$. By (2.7), we have that $R_{\alpha\beta\alpha^{-1}, \alpha\gamma\alpha^{-1}} = (\varphi_\alpha \otimes \varphi_\alpha)(R_{\beta, \gamma}) = \varphi_\alpha(m_\beta) \otimes \varphi_\alpha(n_\gamma)$. Then:

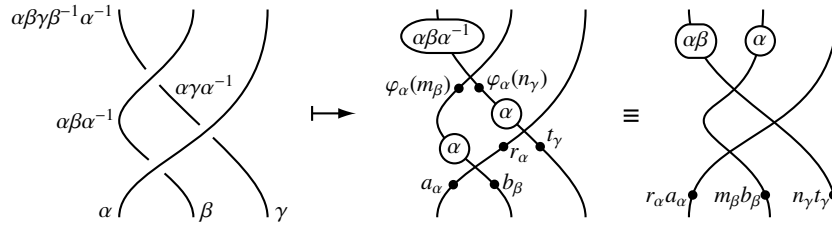

Moreover, writing $R_{\alpha, \beta\gamma\beta^{-1}} = c_\alpha \otimes d_{\beta\gamma\beta^{-1}}$, we have that:

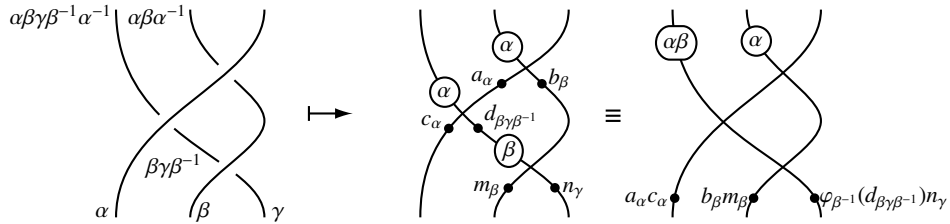

Now

$$\begin{aligned} r_\alpha a_\alpha \otimes m_\beta b_\beta \otimes n_\gamma t_\gamma &= (R_{\beta, \gamma})_{\alpha 23} (R_{\alpha, \gamma})_{1 \beta 3} (R_{\alpha, \beta})_{12 \gamma} \\ &= (R_{\alpha, \beta})_{12 \gamma} [(\text{id}_{H_\alpha} \otimes \varphi_{\beta^{-1}})(R_{\alpha, \beta\gamma\beta^{-1}})]_{1 \beta 3} (R_{\beta, \gamma})_{\alpha 23} \quad \text{by Lemma 2.4(d)} \\ &= a_\alpha c_\alpha \otimes b_\beta m_\beta \otimes \varphi_{\beta^{-1}}(d_{\beta\gamma\beta^{-1}})n_\gamma. \end{aligned}$$

Hence the invariance under the move $\text{III}_{\alpha, \beta, \gamma}$ is verified.

The invariance under the first equivalence of the move $\text{IV}_{\alpha, \beta}$ follows from:

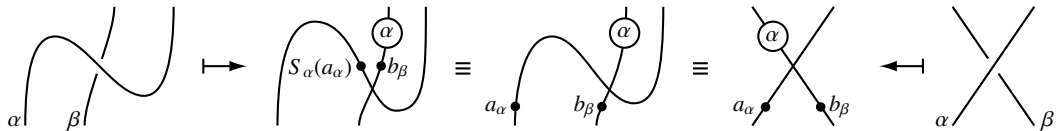

where $R_{\alpha, \beta} = a_\alpha \otimes b_\beta$. For the second one, this can be done similarly.

To show the invariance under the move V_α , we first remark that:

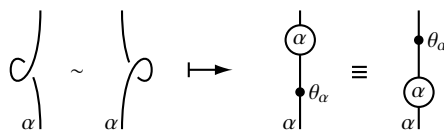

Indeed, write $R_{\alpha,\alpha} = a_\alpha \otimes b_\alpha$. Since $u_\alpha^{-1} = S_\alpha^{-1} S_{\alpha^{-1}}^{-1}(b_\alpha) a_\alpha$ by Lemma 2.5(a), we have that:

$$\begin{array}{c} \alpha \\ | \\ \curvearrowright \end{array} \mapsto \begin{array}{c} \alpha \\ | \\ \bullet \\ | \\ \bullet \\ | \\ \alpha \end{array} \equiv \begin{array}{c} \alpha \\ | \\ \bullet \\ | \\ S_\alpha^{-1} S_{\alpha^{-1}}^{-1}(b_\alpha) a_\alpha \end{array} \equiv \begin{array}{c} \alpha \\ | \\ \bullet \\ | \\ G_\alpha \\ | \\ \bullet \\ | \\ u_\alpha^{-1} \end{array} \equiv \begin{array}{c} \alpha \\ | \\ \bullet \\ | \\ G_\alpha u_\alpha^{-1} = \theta_\alpha \end{array}$$

Moreover, since

$$\begin{aligned} u_{\alpha^{-1}}^{-1} &= m_{\alpha^{-1}}(\text{id}_{H_{\alpha^{-1}}} \otimes S_\alpha S_{\alpha^{-1}}) \sigma_{\alpha^{-1}, \alpha^{-1}}(R_{\alpha^{-1}, \alpha^{-1}}) \quad \text{by Lemma 2.5(a)} \\ &= m_{\alpha^{-1}}(\text{id}_{H_{\alpha^{-1}}} \otimes S_\alpha S_{\alpha^{-1}}) \sigma_{\alpha^{-1}, \alpha^{-1}}(S_{\alpha^{-1}}^{-1} \varphi_{\alpha^{-1}} \otimes S_{\alpha^{-1}}^{-1})(R_{\alpha, \alpha}) \quad \text{by Lemma 2.4(c)} \\ &= S_{\alpha^{-1}}^{-1}(b_\alpha) S_\alpha(\varphi_\alpha(a_\alpha)) \end{aligned}$$

and so

$$\begin{aligned} G_\alpha^{-1} S_{\alpha^{-1}} S_\alpha(\varphi_\alpha(a_\alpha)) b_\alpha &= S_{\alpha^{-1}}(S_{\alpha^{-1}}^{-1}(b_\alpha) S_\alpha(\varphi_\alpha(a_\alpha)) G_{\alpha^{-1}}) \quad \text{by Lemmas 1.1(a) and 2.9(c)} \\ &= S_{\alpha^{-1}}(u_{\alpha^{-1}}^{-1} G_{\alpha^{-1}}) \\ &= S_{\alpha^{-1}}(\theta_{\alpha^{-1}}) \\ &= \theta_\alpha \quad \text{by (2.14),} \end{aligned}$$

we have that:

$$\begin{array}{c} \alpha \\ | \\ \curvearrowright \end{array} \mapsto \begin{array}{c} \alpha \\ | \\ \bullet \\ | \\ \bullet \\ | \\ \alpha \end{array} \equiv \begin{array}{c} \alpha \\ | \\ \bullet \\ | \\ \varphi_{\alpha^{-1}} S_{\alpha^{-1}} S_\alpha(a_\alpha) b_\alpha \end{array} \equiv \begin{array}{c} \alpha \\ | \\ \bullet \\ | \\ G_\alpha^{-1} \\ | \\ \bullet \\ | \\ S_{\alpha^{-1}} S_\alpha(\varphi_{\alpha^{-1}}(a_\alpha)) b_\alpha \end{array} \equiv \begin{array}{c} \alpha \\ | \\ \bullet \\ | \\ \theta_\alpha \end{array}$$

We can conclude by remarking that $\varphi_\alpha(\theta_\alpha) = \theta_\alpha = \varphi_{\alpha^{-1}}(\theta_\alpha)$ by (2.15) and Lemma 2.8(a) and so that:

$$\begin{array}{c} \alpha \\ | \\ \bullet \\ | \\ \theta_\alpha \end{array} \equiv \begin{array}{c} \theta_\alpha \\ | \\ \alpha \end{array}$$

We can show similarly that:

$$\begin{array}{c} \alpha \\ | \\ \curvearrowright \end{array} \sim \begin{array}{c} \alpha \\ | \\ \curvearrowleft \end{array} \mapsto \begin{array}{c} \alpha^{-1} \\ | \\ \bullet \\ | \\ \theta_\alpha^{-1} \end{array} \equiv \begin{array}{c} \theta_\alpha^{-1} \\ | \\ \alpha^{-1} \end{array}$$

It's then easy to verify the invariance under the last move of V_α :

$$\begin{array}{c} \alpha \\ | \\ \curvearrowright \end{array} \mapsto \begin{array}{c} \alpha \\ | \\ \bullet \\ | \\ \theta_\alpha \\ | \\ \bullet \\ | \\ \alpha^{-1} \end{array} \equiv \begin{array}{c} \alpha \\ | \\ \bullet \\ | \\ \theta_\alpha \theta_\alpha^{-1} = 1_\alpha \\ | \\ \alpha^{-1} \end{array} \equiv \begin{array}{c} \alpha \\ | \\ \bullet \\ | \\ \alpha^{-1} \end{array} \equiv \begin{array}{c} 1 \\ | \\ \alpha \end{array} \equiv \begin{array}{c} | \\ \alpha \end{array}$$

This completes the proof of Theorem 4.3.

4.1.6. Basic properties of $\text{Inv}_{\{H, \text{tr}\}}$. Throughout this subsection $H = \{H_\alpha\}_{\alpha \in \pi}$ will denote a ribbon Hopf π -coalgebra with bijective antipode, endowed with a π -trace $\text{tr} = (\text{tr}_\alpha)_{\alpha \in \pi}$.

Let (L, z, g) be a H -compatible π -link. Fix $\alpha \in \pi$. Then $(L, z, \alpha g \alpha^{-1})$ is clearly a H -compatible π -link.

LEMMA 4.5. $\text{Inv}_{\{H, \text{tr}\}}(L, z, \alpha g \alpha^{-1}) = \text{Inv}_{\{H, \text{tr}\}}(L, z, g)$.

When $\alpha \in \text{Im}(g)$, this follows from the invariance of $\text{Inv}_{\{H, \text{tr}\}}$ under the moves of Figure 4.2.

Proof. The lemma follows directly from the facts that, for all $\alpha, \beta, \gamma \in \pi$, the φ_α are algebra isomorphisms, $R_{\alpha\beta\alpha^{-1}, \alpha\gamma\alpha^{-1}} = (\varphi_\alpha \otimes \varphi_\alpha)(R_{\beta, \gamma})$, $S_{\alpha\beta\alpha^{-1}}\varphi_\alpha = \varphi_\alpha S_\beta$, $\varphi_\alpha(G_\beta) = G_{\alpha\beta\alpha^{-1}}$, and $\text{tr}_{\alpha\beta\alpha^{-1}}\varphi_\alpha = \text{tr}_\beta$. \square

Let (L, z, g) be a H -compatible π -link. Suppose that L is the disjoint union of two framed links L_1 and L_2 . Since L_1 and L_2 are contained in two disjoint 3-balls in S^3 , by the Van Kampen theorem, there exist two morphisms $g_1 : \pi_1(S^3 \setminus L_1, z) \rightarrow \pi$ and $g_2 : \pi_1(S^3 \setminus L_2, z) \rightarrow \pi$ such that the diagram of Figure 4.12 is commutative, where the horizontal arrows are induced by the embeddings $(S^3 \setminus L, z) \hookrightarrow (S^3 \setminus L_1, z)$ and $(S^3 \setminus L, z) \hookrightarrow (S^3 \setminus L_2, z)$. It is straightforward that (L_1, z, g_1) and (L_2, z, g_2) are H -compatible.

$$\begin{array}{ccccc}
 \pi_1(S^3 \setminus L_1, z) & \longleftarrow & \pi_1(S^3 \setminus L, z) & \longrightarrow & \pi_1(S^3 \setminus L_2, z) \\
 & \searrow & \downarrow g & \swarrow & \\
 & & \pi & &
 \end{array}$$

The diagram shows a commutative triangle. The top horizontal line consists of three terms: $\pi_1(S^3 \setminus L_1, z)$, $\pi_1(S^3 \setminus L, z)$, and $\pi_1(S^3 \setminus L_2, z)$, connected by left-pointing and right-pointing arrows respectively. From the middle term $\pi_1(S^3 \setminus L, z)$, a vertical arrow labeled g points down to the term π . From $\pi_1(S^3 \setminus L_1, z)$, a diagonal arrow labeled g_1 points down to π . From $\pi_1(S^3 \setminus L_2, z)$, a diagonal arrow labeled g_2 points down to π .

FIGURE 4.12.

LEMMA 4.6. $\text{Inv}_{\{H, \text{tr}\}}(L, z, g) = \text{Inv}_{\{H, \text{tr}\}}(L_1, z, g_1) \text{Inv}_{\{H, \text{tr}\}}(L_2, z, g_2)$.

Proof. Choose a π -colored diagram for (L, z, g) such that the diagrams for L_1 and L_2 are disjoint. It suffices then to remark that the π -colored sub-diagram consisting in L_i ($i = 1, 2$) is a π -colored diagram for (L_i, z, g_i) . \square

Let (L, z, g) be a H -compatible π -link. Consider a *mirror image* of L , that is, the framed link obtained by taking the image of L (and of its framing \tilde{L}) by an orientation-reversing homeomorphism $\rho : S^3 \rightarrow S^3$. Let H^{cop} be the ribbon Hopf π -coalgebra coopposite to H . It is endowed with a π -trace $\text{tr}^{\text{cop}} = (\text{tr}_{\alpha^{-1}})_{\alpha \in \pi}$. By Lemma 4.2, $(\rho(L), \rho(z), g \circ \rho_*^{-1})$ is H -compatible and (L, z, g) is H^{cop} -compatible.

LEMMA 4.7. $\text{Inv}_{\{H, \text{tr}\}}(\rho(L), \rho(z), g \circ \rho_*^{-1}) = \text{Inv}_{\{H^{\text{cop}}, \text{tr}^{\text{cop}}\}}(L, z, g)$.

Proof. Let h be an orientation-preserving homeomorphism of S^3 such that $h(L) \subset \mathbb{R}^3 = S^3 \setminus \infty$, $h(z) = (0, 0, 1)$, and the projection of the framed $h(L)$ onto $\mathbb{R}^2 \times 0$ is a generic diagram D which lies in $] -\infty, 0[\times \mathbb{R} \times 0$. Let r be the orientation-reversing homeomorphism of $S^3 = \mathbb{R} \cup \infty$ given by $r(\infty) = \infty$ and $r(x, y, z) = (-x, y, z)$. The projection of $r \circ h(L)$ onto $\mathbb{R}^2 \times 0$ is then a generic diagram D' of $r \circ h(L)$ which lies in $]0, +\infty[\times \mathbb{R} \times 0$. Note that D' can be obtained from D by applying the plane symmetry $T = r|_{\mathbb{R}^2 \times 0}$ with respect to the line $0 \times \mathbb{R} \times 0$. Color, as in Section 4.1.2, the diagrams D and D' to obtain π -colored diagrams of $(h(L), h(z), g \circ h_*^{-1})$ and $(r \circ h(L), r \circ h(z), g \circ h_*^{-1} \circ r_*^{-1})$ respectively.

Let us remark that if α is the color of a vertical segment of D , then the color of the corresponding segment of D' is α^{-1} . Indeed, if γ is a loop based on $h(z) = r \circ h(z)$ such that $\alpha = g \circ h_*^{-1}([\gamma])$, then $g \circ h_*^{-1} \circ r_*^{-1}([r \circ \gamma^{-1}]) = g \circ h_*^{-1}([\gamma])^{-1} = \alpha^{-1}$, see Figure 4.13.

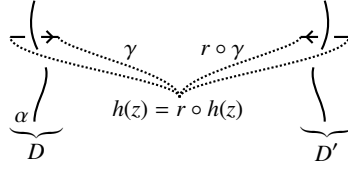

FIGURE 4.13.

Denote by D_f (resp. D'_f) the flat diagram of $h(L)$ (resp. $r \circ h(L)$) obtained from D (resp. D') by applying Step (B) of Section 4.1.4 with H^{cop} (resp. H). The flat diagrams D_f and D'_f are the image one of the other under the symmetry T (the labels of the discs remaining unchanged). Indeed, if we write $R_{\alpha, \beta^{-1}} = a_\alpha \otimes b_{\beta^{-1}}$ so that $R_{\alpha, \beta}^{\text{cop}} = (S_\alpha \otimes \text{id}_{H_{\beta^{-1}}})(R_{\alpha, \beta^{-1}}) = S_\alpha(a_\alpha) \otimes b_{\beta^{-1}}$, then the diagram of Figure 4.14 is commutative.

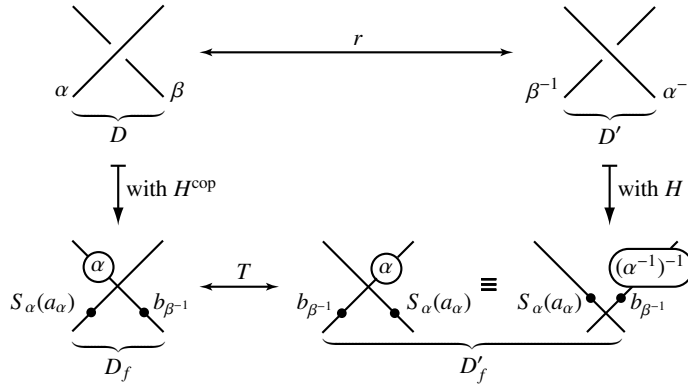

FIGURE 4.14.

Let L_1, \dots, L_m be the components of L . For any $1 \leq i \leq m$, choose a point p_i (other than extrema, labelled discs, and points decorated by algebraic elements) on the flat diagram of a component $h(L_i)$ of $h(L)$ and denote by $p'_i = T(p_i)$ the corresponding point on D'_f . Since $H_\alpha^{\text{cop}} = H_{\alpha^{-1}}$ as an algebra, $S_\alpha^{\text{cop}} = S_{\alpha^{-1}}$, and $\varphi_\beta^{\text{cop}} = \varphi_\beta$, we have that to apply the rules of Figures 4.5 with H^{cop} to D_f is equivalent to apply these rules with H to D'_f (for example, the diagram of Figure 4.15 is commutative, where $\alpha \in \pi$ and $a \in H_\alpha^{\text{cop}} = H_{\alpha^{-1}}$). Therefore we can concentrate the algebraic decoration of D_f (resp. D'_f) on p_i (resp. p'_i) to obtain an element $v_i \in H_{\alpha_i}^{\text{cop}}$ (resp. $v'_i \in H_{\alpha_i^{-1}}$) in such a way that $v_i = v'_i$. Let d_i (resp. d'_i) be the Whitney degree of the flat diagram of $h(L_i)$ (resp. $r \circ h(L_i)$) oriented upwards from p_i (resp. p'_i). Since T is a plane symmetry with respect to a vertical line, we have that $d'_i = -d_i$. Therefore

$$\begin{aligned}
 \text{Inv}_{\{H^{\text{cop}}, \text{tr}^{\text{cop}}\}}(h(L), h(z), g \circ h^{-1}) &= \prod_{i=1}^m \text{tr}_{\alpha_i}^{\text{cop}}((G_{\alpha_i}^{\text{cop}})^{d_i} v_i) \\
 &= \prod_{i=1}^m \text{tr}_{\alpha_i^{-1}}(G_{\alpha_i^{-1}}^{-d_i} v_i) \\
 &= \prod_{i=1}^m \text{tr}_{\alpha_i^{-1}}(G_{\alpha_i^{-1}}^{d'_i} v'_i) \\
 &= \text{Inv}_{\{H, \text{tr}\}}(r \circ h(L), r \circ h(z), g \circ h_*^{-1} \circ r_*^{-1}).
 \end{aligned}$$

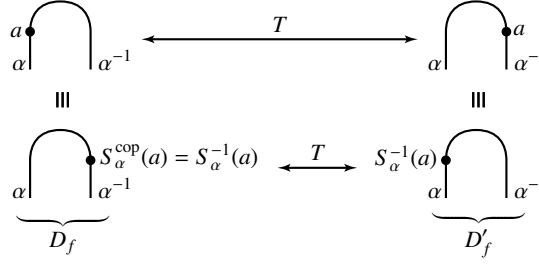

FIGURE 4.15.

By Theorem 4.3, since $r \circ h \circ \rho^{-1}$ and h are orientation-preserving homeomorphisms, we have

$$\text{Inv}_{\{H, \text{tr}\}}(\rho(L), \rho(z), g \circ \rho_*^{-1}) = \text{Inv}_{\{H, \text{tr}\}}(r \circ h(L), r \circ h(z), g \circ h_*^{-1} \circ r_*^{-1})$$

and

$$\text{Inv}_{\{H^{\text{cop}}, \text{tr}^{\text{cop}}\}}(L, z, g) = \text{Inv}_{\{H^{\text{cop}}, \text{tr}^{\text{cop}}\}}(h(L), h(z), g \circ h_*^{-1}).$$

Hence $\text{Inv}_{\{H, \text{tr}\}}(\rho(L), \rho(z), g \circ \rho_*^{-1}) = \text{Inv}_{\{H^{\text{cop}}, \text{tr}^{\text{cop}}\}}(L, z, g)$. \square

4.1.7. Examples. In this subsection, we give some examples of computations of the invariant $\text{Inv}_{\{H, \text{tr}\}}$ of Theorem 4.3 which show that $\text{Inv}_{\{H, \text{tr}\}}$ is not trivial.

EXAMPLE 4.8. Fix an integer $n \geq 2$, set $\pi = \mathbb{Z}/n\mathbb{Z}$, and define a bicharacter $c : \pi \times \pi \rightarrow \mathbb{C}^*$ of π by setting $c(a \pmod{n\mathbb{Z}}, b \pmod{n\mathbb{Z}}) = e^{\frac{2i\pi}{n}ab}$. Let us consider the ribbon Hopf π -coalgebra $H = \mathbb{C}^c$ (see Example 2.17) endowed with the π -trace $\text{tr} = (\text{id}_{\mathbb{C}})_{\alpha \in \pi}$. Let $O_k \subset S^3$ be the framed trivial knot with framing $k \in \mathbb{Z}$ and let $z_k \in S^3 \setminus O_k$. For any $l \in \mathbb{Z}$, define $g_l : \pi_1(S^3 \setminus O_k, z_k) \cong \mathbb{Z} \rightarrow \pi$ by $g_l(1) = l \pmod{n\mathbb{Z}}$. The π -link (O_k, z_k, g_l) is clearly H -compatible (since $\pi = \mathbb{Z}/n\mathbb{Z}$ is commutative and the crossing of $H = \mathbb{C}^c$ is trivial). One easily gets that

$$\begin{aligned} \text{Inv}_{\{H, \text{tr}\}}(O_k, z_k, g_l) &= \text{tr}_{g_l(1)}(G_{g_l(1)}^{-1} \theta_{g_l(1)}^k) \\ &= c(l \pmod{n\mathbb{Z}}, l \pmod{n\mathbb{Z}})^k \\ &= e^{\frac{2i\pi k l^2}{n}}. \end{aligned}$$

In particular $\text{Inv}_{\{H, \text{tr}\}}(O_1, z_1, g_0) = 1 \neq e^{\frac{2i\pi}{n}} = \text{Inv}_{\{H, \text{tr}\}}(O_1, z_1, g_1)$.

EXAMPLE 4.9. Consider the trefoil T as in Figure 4.16(a). The Wirtinger presentation of the group of T is $\pi_1(T) = \langle x, y, z \mid xy = yz = zx \rangle$. Let $g : \pi_1(T) \rightarrow \pi$. Denote $\alpha = g(x)$, $\beta = g(y)$, and $\gamma = g(z)$. The coloration by g of the diagram of T is depicted in Figure 4.16(b). Let $H = \{H_\alpha\}_{\alpha \in \pi}$ be a ribbon Hopf π -coalgebra endowed with a trace tr . Suppose that the π -trefoil represented by Figure 4.16(b) is H -compatible. Write $R_{\beta^{-1}, \alpha^{-1}} = \sum_i a_i \otimes b_i$, $R_{\gamma, \alpha} = \sum_j c_j \otimes d_j$, and $R_{\alpha, \beta} = \sum_k e_k \otimes f_k$. The detailed application of Steps (B) and (C) of Section 4.1.4 is given in Figure 4.16(c). Therefore we get that

$$\text{Inv}_{\{H, \text{tr}\}}(T, g) = \sum_{i, j, k} \text{tr}_\alpha \left(G_\alpha^2 \varphi_{\gamma^{-1}} S_\beta^{-1} (a_i S_{\beta^{-1}}^{-1} (f_k)) d_j e_k S_{\alpha^{-1}} (b_i) S_{\alpha^{-1}} \varphi_\beta S_\gamma (c_j) \right).$$

Fix an integer $n \geq 2$, set $\pi = \mathbb{Z}/n\mathbb{Z}$, and consider the ribbon Hopf π -coalgebra $H = \mathbb{C}^c$ (see Example 2.17), where $c : \pi \times \pi \rightarrow \mathbb{C}^*$ is the bicharacter of π given by $c(a \pmod{n\mathbb{Z}}, b \pmod{n\mathbb{Z}}) = e^{\frac{2i\pi}{n}ab}$. The family $\text{tr} = (\text{id}_{\mathbb{C}})_{\alpha \in \pi}$ is a π -trace for H . Note that all π -links are H -compatible (since $\pi = \mathbb{Z}/n\mathbb{Z}$ is commutative and the crossing of $H = \mathbb{C}^c$ is trivial). For $l \in \mathbb{Z}/n\mathbb{Z}$, we define

$$g_l : \begin{cases} \pi_1(T) = \langle x, y, z \mid xy = yz = zx \rangle & \rightarrow \mathbb{Z}/n\mathbb{Z} \\ x, y, z & \mapsto l \end{cases}.$$

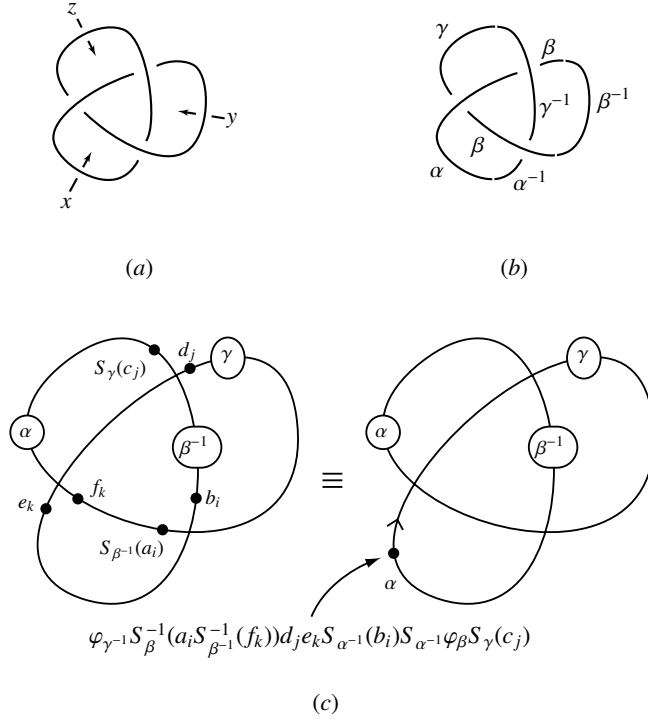

FIGURE 4.16.

Then

$$\text{Inv}_{\{\mathbb{C}^c, \text{tr}\}}(T, g_l) = c(-l, -l) c(l, l) c(l, l) = \exp\left(\frac{6i\pi l^2}{n}\right).$$

For example, for $n = 6$, we get that $\text{Inv}_{\{H, \text{tr}\}}(T, g_0) = 1 \neq -1 = \text{Inv}_{\{H, \text{tr}\}}(T, g_1)$.

4.2. Invariants of π -manifolds

Our goal in this section is to normalize the invariant of π -links constructed in the previous section to an invariant of principal π -bundles over 3-manifolds.

4.2.1. π -manifolds. Recall that π is a discrete group. Following [48], a π -manifold is a couple (M, ξ) where M is a closed, connected, and oriented 3-manifold and ξ is a principal π -bundle over M , that is, since π is discrete, a regular covering $\tilde{M} \rightarrow M$ with group of automorphisms π . The space \tilde{M} (resp. M) is called the *total space* (resp. *base space*) of ξ . Two π -manifolds (M, ξ) and (M', ξ') are said to be *equivalent* if there exists a homeomorphism $\tilde{h} : \tilde{M} \rightarrow \tilde{M}'$ which preserves the action of π and induces an orientation-preserving homeomorphism $h : M \rightarrow M'$.

A π -manifold (M, ξ) is said to be *pointed* when the total space \tilde{M} of ξ is endowed with a base point $\tilde{x} \in \tilde{M}$. Two pointed π -manifolds (M, ξ, \tilde{x}) and (M', ξ', \tilde{x}') are said to be *equivalent* if there exists an equivalence $\tilde{h} : \tilde{M} \rightarrow \tilde{M}'$ between them such that $h(\tilde{x}) = h(\tilde{x}')$.

Let (M, ξ, \tilde{x}) be a pointed π -manifold. Denote by $x \in M$ the image of $\tilde{x} \in \tilde{M}$ under the covering $\tilde{M} \rightarrow M$. We can associate to the pointed π -manifold (M, ξ, \tilde{x}) a morphism $f : \pi_1(M, x) \rightarrow \pi$, called *monodromy of ξ at \tilde{x}* , by the following procedure: any loop γ in (M, x) uniquely lifts to a path $\tilde{\gamma}$ in \tilde{M} beginning at \tilde{x} . The path $\tilde{\gamma}$ ends at $\alpha \cdot \tilde{x}$ for a unique $\alpha \in \pi$. The monodromy is defined

by $f([\gamma]) = \alpha$, where $[\gamma]$ denotes the homotopy class in $\pi_1(M, x)$ of the loop γ . This leads to the triple (M, x, f) .

Conversely, a triple (M, x, f) where M is a closed, connected, and oriented 3-manifold, $x \in M$, and $f : \pi_1(M, x) \rightarrow \pi$ is a group homomorphism leads to a pointed π -manifold uniquely determined up to equivalence (see [11, PROPOSITION 14.1]). When convenient, we will adopt this second point of view. In particular, under this point of view, two pointed π -manifolds (M, x, f) and (M', x', f') are equivalent if there exists an orientation-preserving homeomorphism $h : M \rightarrow M'$ such that $h(x) = x'$ and $f' \circ h_* = f$, where $h_* : \pi_1(M, x) \rightarrow \pi_1(M', x')$ is the induced group isomorphism.

4.2.2. Surgery along π -links. For any framed link L in S^3 , we will denote by S_L^3 the 3-manifold obtained from S^3 by surgery along L (see [27]) and by $i_L : S^3 \setminus L \hookrightarrow S_L^3$ the (canonical) embedding. A pointed π -manifold (M, x, f) is said to be *obtained from S^3 by surgery along a π -link (L, z, g)* if there exists an orientation-preserving homeomorphism $h : S_L^3 \rightarrow M$ such that $i_L(z) = h^{-1}(x)$ and $g = f \circ h_* \circ (i_L)_*$, where $h_* : \pi_1(S_L^3, h^{-1}(x)) \rightarrow \pi_1(M, x)$ and $(i_L)_* : \pi_1(S^3 \setminus L, z) \rightarrow \pi_1(S_L^3, i_L(z))$ are the induced group homomorphisms.

LEMMA 4.10. *Every pointed π -manifold can be obtained from S^3 by surgery along a π -link.*

Proof. Let (M, x, f) be a pointed π -manifold. Since M is a closed, connected, and oriented 3-manifold, it can be obtained from S^3 by (integer) surgery, i.e., there exist a framed link $L \subset S^3$ and an orientation-preserving homeomorphism $h : S_L^3 \rightarrow M$. Moreover L can always be chosen such that $h^{-1}(x) \in i_L(S^3 \setminus L)$. Let $z \in S^3 \setminus L$ such that $i_L(z) = h^{-1}(x)$. Set $g = f \circ h_* \circ (i_L)_*$. Hence (M, x, f) is obtained from S^3 by surgery along (L, z, g) . \square

4.2.3. Invariants of π -manifolds. Let $H = \{H_\alpha\}_{\alpha \in \pi}$ be a finite type unimodular ribbon Hopf π -coalgebra and $\lambda = (\lambda_\alpha)_{\alpha \in \pi}$ be a (non-zero) right π -integral for H such that $\lambda_1(\theta_1) \neq 0$ and $\lambda_1(\theta_1^{-1}) \neq 0$, where $\theta = \{\theta_\alpha\}_{\alpha \in \pi}$ denotes the twist of H . By Theorem 2.14, $\text{tr}^\lambda = (x \in H_\alpha \mapsto \text{tr}_\alpha^\lambda(x) = \lambda_\alpha(G_\alpha x) \in \mathbb{k})_{\alpha \in \pi}$ is a π -trace for H , where $G = (G_\alpha)_{\alpha \in \pi}$ is the spherical π -grouplike element of H .

LEMMA 4.11. *If (M, x, f) is a pointed π -manifold obtained from S^3 by surgery along a π -link (L, z, g) , then (L, z, g) is H -compatible.*

Proof. Let C be a component of L , γ be a path in $S^3 \setminus L$ connecting z to \bar{C} and ν be an orientation of \bar{C} . By definition of the surgery, $i_L(\bar{C})$ bounds a disk in S_L^3 . Therefore $[i_L(\gamma)^{-1} i_L(\bar{C}) i_L(\gamma)] = 1$ in $\pi_1(S_L^3, i_L(z))$, that is, $(i_L)_*(\lambda_{(\gamma, \nu)}) = 1$, where $\lambda_{(\gamma, \nu)} = [\gamma^{-1} \bar{C} \gamma] \in \pi_1(S^3 \setminus L, z)$ (here the oriented circle \bar{C} is viewed as a loop based on the point $\gamma(1)$). Since (M, x, f) is obtained from S^3 by surgery along (L, z, g) , there exists an orientation-preserving homeomorphism $h : S_L^3 \rightarrow M$ such that $i_L(z) = h^{-1}(x)$ and $g = f \circ h_* \circ (i_L)_*$. Then $g(\lambda_{(\gamma, \nu)}) = f \circ h_* \circ (i_L)_*(\lambda_{(\gamma, \nu)}) = f \circ h_*(1) = 1$ and hence $g(\lambda_{(\gamma, \nu)}) \in Z(\pi)$ and $\varphi_{g(\lambda_{(\gamma, \nu)})} = \varphi_1 = \text{id}$ (by Lemma 2.1). \square

Let (M, ξ) be a π -manifold. Choose a point \tilde{x} in the total space \tilde{M} of ξ . Denote by x the projection of \tilde{x} under the covering $\tilde{M} \rightarrow M$ and by $f : \pi_1(M, x) \rightarrow \pi$ the monodromy of ξ at \tilde{x} . By Lemma 4.10, we can present the pointed π -manifold (M, x, f) by a surgery along a π -link (L, z, g) . Set

$$\tau_H(M, \xi) = \lambda_1(\theta_1)^{b_-(L) - n_L} \lambda_1(\theta_1^{-1})^{-b_-(L)} \text{Inv}_{\{H, \text{tr}^\lambda\}}(L, z, g),$$

where $b_-(L)$ is the number of strictly negative eigenvalues of the linking matrix of the framed link L (with framing numbers on the diagonal) and n_L is the number of components of L . Note that this scalar is well-defined since $\lambda_1(\theta_1)$ and $\lambda_1(\theta_1^{-1})$ are supposed to be non-zero and (L, z, g) is H -compatible (by Lemma 4.11).

THEOREM 4.12. *Let $H = \{H_\alpha\}_{\alpha \in \pi}$ be a finite type unimodular ribbon Hopf π -coalgebra and $\lambda = (\lambda_\alpha)_{\alpha \in \pi}$ be a right π -integral for H such that $\lambda_1(\theta_1) \neq 0$ and $\lambda_1(\theta_1^{-1}) \neq 0$, where $\theta = \{\theta_\alpha\}_{\alpha \in \pi}$ denotes the twist of H . Then τ_H is an invariant of π -manifolds.*

The theorem is proven in Section 4.2.4.

Recall that the space of right π -integrals for H is one-dimensional (see Theorem 1.13) and remark that the invariant τ_H remains unchanged if we replace λ by a scalar multiple $k\lambda$, with $k \in \mathbb{k}^*$. Therefore τ_H does not depend of the choice of the (non-zero) right π -integral for H used to compute it.

When $\pi = 1$, for any closed, connected, and oriented 3-manifold M , $\tau_H(M, M)$ is equal to $(\lambda_1(\theta_1^{-1})/\lambda_1(\theta_1))^{\frac{1}{2} \dim H_1(M)}$ times the Hennings' invariant of M (in the Kauffman-Radford formulation of [17]) calculated from the ribbon Hopf algebra H_1^{op} (endowed with the R -matrix $R_{1,1}^{-1}$ and the twist θ_1^{-1}) and the right integral λ_1 . Note that here a square root of $\lambda_1(\theta_1^{-1})/\lambda_1(\theta_1)$ is assumed to exist.

Recall that, given a topological group G , a principal G -bundle is called *flat* when its transition functions are locally constant. Therefore equivalence class of flat principal G -bundle are in one-to-one correspondence with equivalence class of principal G_d -bundle, where G_d denotes the group G endowed with the discrete topology. Hence, when the group π is not discrete, the invariant τ_H may be viewed as an invariant of flat principal π -bundles over 3-manifolds.

The next example shows that the invariant τ_H is not trivial.

EXAMPLE 4.13. Consider the ribbon Hopf $(\frac{1}{N}\mathbb{Z})/\mathbb{Z}$ -coalgebra $A = \{A_\alpha\}_{\alpha \in (\frac{1}{N}\mathbb{Z})/\mathbb{Z}}$ of Example 2.19, where $N \geq 1$, which is studied in Appendix A. We restrict to the case $r = 2$. Let us denote by $(\lambda_\alpha)_{\alpha \in (\frac{1}{N}\mathbb{Z})/\mathbb{Z}}$ the right $(\frac{1}{N}\mathbb{Z})/\mathbb{Z}$ -integral of Lemma A.1. Fix $p \geq 1$ and let ξ be a principal π -bundle over the lens space $L(p, 1)$. Denote by $f : \pi_1(L(p, 1)) \cong \mathbb{Z}/p\mathbb{Z} \rightarrow (\frac{1}{N}\mathbb{Z})/\mathbb{Z}$ the monodromy of ξ and set $\alpha = f(1) \in (\frac{1}{N}\mathbb{Z})/\mathbb{Z}$. Note that $p\alpha = 0$. Since the lens space $L(p, 1)$ is obtained by surgery of S^3 along the trivial knot with framing p , we have that

$$\tau_A(L(p, 1), \xi) = \lambda_0(\theta_0)^{-1} \lambda_\alpha(\theta_\alpha^p).$$

By Lemma A.4, $\lambda_0(\theta_0) = -\frac{i}{2}$ and $\lambda_\alpha(\theta_\alpha^p) = -\frac{i}{2}p$ if $\alpha = 0$ and $\lambda_\alpha(\theta_\alpha^p) = 0$ otherwise. Therefore

$$\tau_A(L(p, 1), \xi) = \begin{cases} p & \text{if } \xi \text{ is the trivial bundle,} \\ 0 & \text{otherwise.} \end{cases}$$

To obtain more interesting examples (from the topological point of view), one may start from ribbon Hopf π -coalgebras with non-trivial crossing. To produce examples of such Hopf π -coalgebras (in particular for π non abelian), it would be useful to define and study crossed Lie (co)algebras, their enveloping (co)algebras, and their quantum deformations in a similar way as the machinery of quantum groups (see, e.g., [15, 42]).

4.2.4. Proof of Theorem 4.12. Let us first show that $\tau_H(M, \xi)$ does not depend on the choice of the base point \tilde{x} in the total space \tilde{M} of the π -manifold (M, ξ) . Let \tilde{x}' be another point in \tilde{M} . Denote by x (resp. x') the projection of \tilde{x} (resp. \tilde{x}') under the covering $\tilde{M} \rightarrow M$ and by $f : \pi_1(M, x) \rightarrow \pi$ (resp. $f' : \pi_1(M, x') \rightarrow \pi$) the monodromy of ξ at \tilde{x} (resp. \tilde{x}'). Let (L, z, g) a π -link along which the pointed π -manifold (M, x, f) is obtained by a surgery. Recall that there exists an orientation-preserving homeomorphism $h : S_L^3 \rightarrow M$ such that $i_L(z) = h^{-1}(x)$ and $g = f \circ h_* \circ (i_L)_*$, where $i_L : S^3 \setminus L \hookrightarrow S_L^3$ is the (canonical) embedding and $(i_L)_*$ and h_* are the homomorphisms induced in homotopy by i_L and h respectively. Without loss of generality, we can assume that $x' \in h \circ i_L(S^3 \setminus L)$. Let $z' \in S^3 \setminus L$ such that $i_L(z') = h^{-1}(x')$. Since $S^3 \setminus L$ is connected, there exists a path $\gamma : [0, 1] \rightarrow S^3 \setminus L$ connecting $z = \gamma(0)$ to $z' = \gamma(1)$. Define $\phi_\gamma : \pi_1(S^3 \setminus L, z') \rightarrow \pi_1(S^3 \setminus L, z)$

by setting $\phi_\gamma([\ell]) = [\gamma^{-1}\ell\gamma]$ for any loop ℓ in $(S^3 \setminus L, z')$. Set $g' = g \circ \phi_\gamma : \pi_1(S^3 \setminus L, z') \rightarrow \pi$. Note that the π -links (L, z, g) and (L, z', g') are equivalent: they are ambiently isotopic via an isotopy of the identity map id_{S^3} which pushes z along γ and is constant in a neighborhood of L . The path $\rho = h \circ i_L \circ \gamma : [0, 1] \rightarrow M$ connects the point $\rho(0) = h(i_L(z)) = x$ to the point $\rho(1) = h(i_L(z')) = x'$. Define $\phi_\rho : \pi_1(M, x') \rightarrow \pi_1(M, x)$ by setting $\phi_\rho([\ell]) = [\rho^{-1}\ell\rho]$ for any loop ℓ in (M, x') . Note that, by construction,

$$\phi_\rho \circ h_* \circ (i_L)_* = h_* \circ (i_L)_* \circ \phi_\gamma : \pi_1(S^3 \setminus L, z') \rightarrow \pi_1(M, x).$$

Then $g' = g \circ \phi_\gamma = f \circ h_* \circ (i_L)_* \circ \phi_\gamma = (f \circ \phi_\rho) \circ h_* \circ (i_L)_*$ and so the pointed π -manifold $(M, x', f \circ \phi_\rho)$ is obtained by surgery along the π -link (L, z', g') . Since π is a discrete group, the path $\rho : [0, 1] \rightarrow M$ uniquely lifts to a path $\tilde{\rho} : [0, 1] \rightarrow \tilde{M}$ such that $\tilde{\rho}(0) = \tilde{x}$. Since \tilde{x}' and $\tilde{\rho}(1)$ belong to the same fiber (over x'), there exists $\alpha \in \pi$ such that $\tilde{\rho}(1) = \alpha \cdot \tilde{x}'$. Using the definition of the monodromy, we obtain that $f' = \alpha^{-1}(f \circ \phi_\rho)\alpha$. Therefore

$$\alpha^{-1}g'\alpha = (\alpha^{-1}(f \circ \phi_\rho)\alpha) \circ h_* \circ (i_L)_* = f' \circ h_* \circ (i_L)_*$$

and so the pointed π -manifold (M, x', f') is obtained by surgery along the π -link $(L, z', \alpha^{-1}g'\alpha)$. Finally, recalling that (L, z, g) and (L, z', g') are equivalent (H -compatible) π -links, we have

$$\begin{aligned} \text{Inv}_{\{H, \text{tr}^1\}}(L, z', \alpha^{-1}g'\alpha) &= \text{Inv}_{\{H, \text{tr}^1\}}(L, z', g') \quad \text{Lemma 4.5} \\ &= \text{Inv}_{\{H, \text{tr}^1\}}(L, z, g) \quad \text{by Theorem 4.3.} \end{aligned}$$

Hence $\tau_H(M, \xi)$ does not depend on the choice of the base point \tilde{x} in \tilde{M} .

It remains to show that τ_H is an invariant of pointed π -manifolds. Let us describe the Kirby moves (in the form of Fenn and Rourke) in terms of π -colored link diagrams. Two π -links are said to be related by a *Kirby 1-move* (resp. a *special Kirby (± 1) -move*) if they may be presented by π -colored diagrams which can be obtained one from the other by interchanging the π -colored tangle diagram $K_{\alpha_1, \dots, \alpha_n}$ of Figure 4.17(a) with the π -colored tangle diagram $I_{\alpha_1, \dots, \alpha_n}$ of Figure 4.17(b), where $n \geq 1$ and $\alpha_1, \dots, \alpha_n \in \pi$ (resp. by adding or deleting a disjoint diagram of a circle with framing ± 1 whose vertical segments are colored by the neutral element 1 of π).

LEMMA 4.14. *Let (M, x, f) and (M', x', f') be two equivalent pointed π -manifolds. Suppose that (L, z, g) and (L', z', g') are two π -links along which (M, x, f) and (M', x', f') are respectively obtained from S^3 by surgery. Then there exists a finite sequence $(L_0, z_0, g_0), \dots, (L_n, z_n, g_n)$ of π -links such that $(L_0, z_0, g_0) = (L, z, g)$, $(L_n, z_n, g_n) = (L', z', g')$ and, for any $1 \leq i \leq n$, $(L_{i-1}, z_{i-1}, g_{i-1})$ and (L_i, z_i, g_i) are equivalent π -links or are related by a Kirby 1-move or a special Kirby (± 1) -move.*

Proof. Since (M, x, f) and (M', x', f') are obtained from S^3 by surgery along (L, z, g) or (L', z', g') , there exist two orientation-preserving homeomorphisms $h : S_L^3 \rightarrow M$ and $h' : S_{L'}^3 \rightarrow M'$ such that $i_L(z) = h^{-1}(x)$, $i_{L'}(z') = h'^{-1}(x')$, $g = f \circ h_* \circ (i_L)_*$, and $g' = f' \circ h'_* \circ (i_{L'})_*$. Since (M, x, f) and (M', x', f') are equivalent, there exists an orientation-preserving homeomorphism $\phi : M \rightarrow M'$ such that $\phi(x) = x'$ and $f' \circ \phi_* = f$. It is implicit in the proof given in [19] of the Kirby theorem, refined in [10] and [40], that the (orientation-preserving) homeomorphism $h'^{-1} \circ \phi \circ h : S_L^3 \rightarrow S_{L'}^3$ can be decomposed into isotopies, Kirby 1-moves, and special Kirby (± 1) -moves, i.e., that there exist a finite sequence $L_0 = L, L_1, \dots, L_n = L'$ of framed links in S^3 and a finite sequence $h_1 : S_{L_0}^3 \rightarrow S_{L_1}^3, \dots, h_n : S_{L_{n-1}}^3 \rightarrow S_{L_n}^3$ of orientation-preserving homeomorphisms such that $h'^{-1} \circ \phi \circ h = h_n \circ \dots \circ h_1$ and h_i comes from an isotopy, a Kirby 1-move or a special Kirby (± 1) -move between L_{i-1} and L_i .

Without loss of generality, we can assume that $h_i \circ \dots \circ h_1 \circ h^{-1}(x) \in i_{L_i}(S^3 \setminus L_i)$ for any $1 \leq i \leq n$. Let $z_i \in S^3 \setminus L_i$ such that $i_{L_i}(z_i) = h_i \circ \dots \circ h_1 \circ h^{-1}(x)$. Note that $z' = z_n$. Set

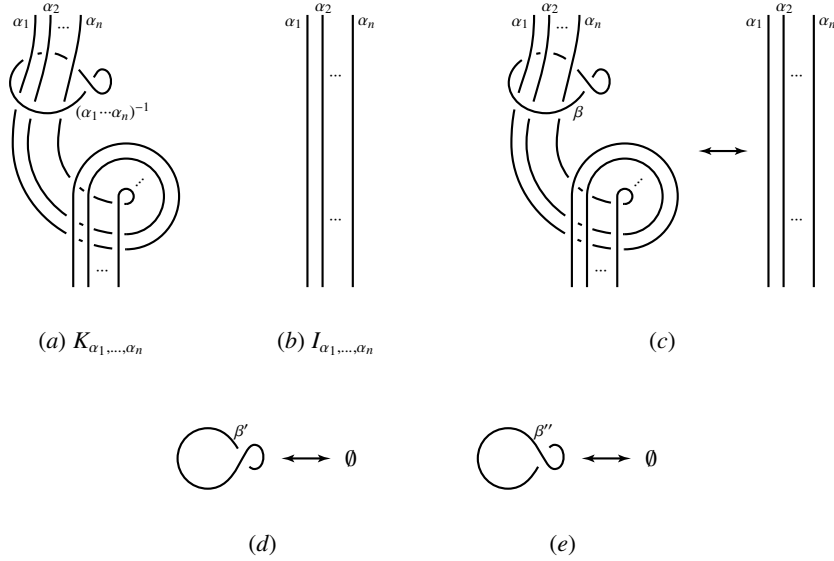
FIGURE 4.17. π -colored Kirby moves

$(L_0, z_0, g_0) = (L, z, g)$ and define $g_i = f \circ h_* \circ (h_1^{-1})_* \circ \cdots \circ (h_i^{-1})_* \circ (i_{L_i})_* : \pi_1(S^3 \setminus L_i, z_i) \rightarrow \pi$ for any $1 \leq i \leq n$. Since

$$g_n = f \circ h_* \circ (h_1^{-1})_* \circ \cdots \circ (h_n^{-1})_* \circ (i_{L_n})_* = f \circ \phi_*^{-1} \circ h'_* \circ (i_{L'})_* = f' \circ h'_* \circ (i_{L'})_* = g$$

we have that $(L_n, z_n, g_n) = (L', z', g')$.

Fix $1 \leq i \leq n$. If h_i comes from an isotopy of S^3 between L_{i-1} and L_i , then it is straightforward that $(L_{i-1}, z_{i-1}, g_{i-1})$ and (L_i, z_i, g_i) are equivalent π -links. Suppose that h_i comes from a Kirby move between L_{i-1} and L_i . Then there exists an open 3-ball U in S^3 (inside which the Kirby move is performed) such that $S^3 \setminus (L_i \cup U) = S^3 \setminus (L_{i-1} \cup U)$ and $i_{L_i|S^3 \setminus (L_i \cup U)} = h_i \circ i_{L_{i-1}|S^3 \setminus (L_{i-1} \cup U)}$. Moreover U can be chosen so that $z_i \in S^3 \setminus (L_i \cup U)$. Then $z_{i-1} = z_i$ since $i_{L_i}(z_i) = h_i \circ \cdots \circ h_1 \circ h^{-1}(x) = h_i(i_{L_{i-1}}(z_{i-1})) = i_{L_i}(z_{i-1})$. Therefore the following diagram is commutative:

$$\begin{array}{ccc} \pi_1(S^3 \setminus (L_{i-1} \cup U), z_{i-1}) & \xlongequal{\quad} & \pi_1(S^3 \setminus (L_i \cup U), z_i) \\ \downarrow & & \downarrow \\ \pi_1(S^3 \setminus L_{i-1}, z_{i-1}) & \xrightarrow{g_{i-1}} \pi \xleftarrow{g_i} & \pi_1(S^3 \setminus L_i, z_i) \end{array}$$

Hence $(L_{i-1}, z_{i-1}, g_{i-1})$ and (L_i, z_i, g_i) can be presented by π -colored link diagrams which are identical except for pieces shown in Figure 4.17(c), 4.17(d), or 4.17(e), where $n \geq 1$ and $\alpha_1, \dots, \alpha_n, \beta \in \pi$, $\beta' \in \pi$, or $\beta'' \in \pi$. Now, since g_{i-1} and g_i vanish on the (homotopy) longitudes (see the proof of Lemma 4.11), we have that $\alpha_1 \cdots \alpha_n \beta = 1$ and so $\beta = (\alpha_1 \cdots \alpha_n)^{-1}$, $\beta' = 1$, or $\beta'' = 1$. Therefore $(L_{i-1}, z_{i-1}, g_{i-1})$ and (L_i, z_i, g_i) are related by a Kirby 1-move or a special Kirby (± 1) -move. \square

By Lemma 4.14, it remains to show that if (L, z, g) and (L', z', g') are two H -compatible π -links which are equivalent, related by a special Kirby (± 1) -move, or related by a Kirby 1-move, then we have that

$$(4.7) \quad \begin{aligned} & \lambda_1(\theta_1)^{b-(L)-n_L} \lambda_1(\theta_1^{-1})^{-b-(L)} \text{Inv}_{\{H, \text{tr}^t\}}(L, z, g) \\ &= \lambda_1(\theta_1)^{b-(L')-n_{L'}} \lambda_1(\theta_1^{-1})^{-b-(L')} \text{Inv}_{\{H, \text{tr}^t\}}(L', z', g'). \end{aligned}$$

When (L, z, g) and (L', z', g') are equivalent H -compatible π -links, (4.7) follows directly from Theorem 4.3 and from the facts that $b_-(L) = b_-(L')$ and $n_L = n_{L'}$ (since L and L' are in particular isotopic framed links).

Suppose that a π -colored diagram of (L', z', g') is obtained from one of (L, z, g) by adding an unknotted circle C^ν with framing $\nu = \pm 1$, unlinked with the other components of L , whose vertical segments are colored by the neutral element 1 of π . Using the computations of Figure 4.18, we obtain that $\text{Inv}_{\{H, \text{tr}^\lambda\}}(L', z', g') = \lambda_1(\theta_1^\nu) \text{Inv}_{\{H, \text{tr}^\lambda\}}(L, z, g)$. Since $n_{L'} = n_{L \amalg C^\nu} = n_L + 1$ and $b_-(L') = b_-(L \amalg C^\nu)$ equals $b_-(L)$ if $\nu = 1$ or $b_-(L) + 1$ if $\nu = -1$, we get the equality (4.7).

$$\begin{aligned} \nu = +1: & \quad \text{Diagram of a circle with framing 1} \mapsto \text{Diagram of a circle with framing 1 and a dot labeled } \theta_1 \equiv \text{tr}_1^\lambda(G_1^{-1}\theta_1) = \lambda_1(\theta_1) \\ \nu = -1: & \quad \text{Diagram of a circle with framing 1} \mapsto \text{Diagram of a circle with framing 1 and a dot labeled } \theta_1^{-1} \equiv \text{tr}_1^\lambda(G_1^{-1}\theta_1^{-1}) = \lambda_1(\theta_1^{-1}) \end{aligned}$$

FIGURE 4.18.

Suppose that a π -colored diagram of (L, z, g) is obtained from one of (L', z', g') by replacing the π -colored tangle diagram $K_{\alpha_1, \dots, \alpha_n}$ of Figure 4.17(a) with the π -colored tangle diagram $I_{\alpha_1, \dots, \alpha_n}$ of Figure 4.17(b) for some $n \geq 1$ and $\alpha_1, \dots, \alpha_n \in \pi$. In this case $b_-(L') = b_-(L)$ and $n_{L'} = n_L + 1$. Therefore we have to show that $\text{Inv}_{\{H, \text{tr}^\lambda\}}(L', z', g') = \lambda_1(\theta_1) \text{Inv}_{\{H, \text{tr}^\lambda\}}(L, z, g)$. Hence it suffices to verify that:

$$(4.8) \quad K_{\alpha_1, \dots, \alpha_n} \mapsto \lambda_1(\theta_1) \begin{array}{c} | \\ 1_{\alpha_1} \\ | \\ \alpha_1 \end{array} \cdots \begin{array}{c} | \\ 1_{\alpha_n} \\ | \\ \alpha_n \end{array}$$

Let us show (4.8) by induction on $n \geq 1$. For $n = 1$, let $\alpha \in \pi$. Write $R_{\alpha, \alpha^{-1}} = a_\alpha \otimes b_{\alpha^{-1}}$ and $R_{\alpha^{-1}, \alpha} = c_{\alpha^{-1}} \otimes d_\alpha$. Since

$$\begin{aligned} & \text{tr}_{\alpha^{-1}}^\lambda(G_{\alpha^{-1}}^{-1} \varphi_\alpha(b_{\alpha^{-1}}) \theta_{\alpha^{-1}} c_{\alpha^{-1}}) a_\alpha \varphi_{\alpha^{-1}}(d_\alpha) \theta_\alpha \\ &= \lambda_{\alpha^{-1}}(\theta_{\alpha^{-1}} b_{\alpha^{-1}} c_{\alpha^{-1}}) \theta_\alpha \varphi_\alpha(a_\alpha) d_\alpha \quad \text{by (2.13) and Lemma 2.8(a)} \\ &= (\lambda_{\alpha^{-1}} \otimes \text{id}_{H_\alpha})((\theta_{\alpha^{-1}} \otimes \theta_\alpha) \cdot (\sigma_{\alpha, \alpha^{-1}}(\varphi_\alpha \otimes \text{id}_{H_{\alpha^{-1}}})(R_{\alpha, \alpha^{-1}})) \cdot R_{\alpha^{-1}, \alpha}) \quad \text{by (2.16)} \\ &= (\lambda_{\alpha^{-1}} \otimes \text{id}_{H_\alpha}) \Delta_{\alpha^{-1}, \alpha}(\theta_1) \\ &= \lambda_1(\theta_1) 1_\alpha \quad \text{by (1.12),} \end{aligned}$$

we have the equalities depicted in Figure 4.19. Hence (4.8) is true for $n = 1$.

Suppose that (4.8) is true for $n \geq 1$ and let $\alpha_1, \dots, \alpha_{n+1} \in \pi$. Denote by C the component of the π -colored (n, n) -tangle diagram $K_{\alpha_1, \dots, \alpha_n, \alpha_{n+1}}$ colored by $\alpha_n \alpha_{n+1}$ and by C' (resp. C'') the component of the π -colored $(n+1, n+1)$ -tangle diagram $K_{\alpha_1, \dots, \alpha_n, \alpha_{n+1}}$ colored by α_n (resp. α_{n+1}). Note that if α and β are the colors of two parallel vertical segments of C' and C'' , then the color of the corresponding vertical segment of C is either $\alpha\beta$ or $\beta\alpha$ depending if the segment of C' is on the left or on the right of the segment of C'' . Using the hypothesis of induction and since $\Delta_{\alpha_n, \alpha_{n+1}}(1_{\alpha_n \alpha_{n+1}}) = 1_{\alpha_n} \otimes 1_{\alpha_{n+1}}$, we have that (4.8) for $n+1$ follows from the next lemma.

LEMMA 4.15. *The flat diagram obtained from $K_{\alpha_1, \dots, \alpha_n, \alpha_{n+1}}$ can be deduced from the one obtained from $K_{\alpha_1, \dots, \alpha_n, \alpha_{n+1}}$ by the following splitting procedure:*

- (a) *the algebraic decoration and the labelled discs of the components other than C remain unchanged;*

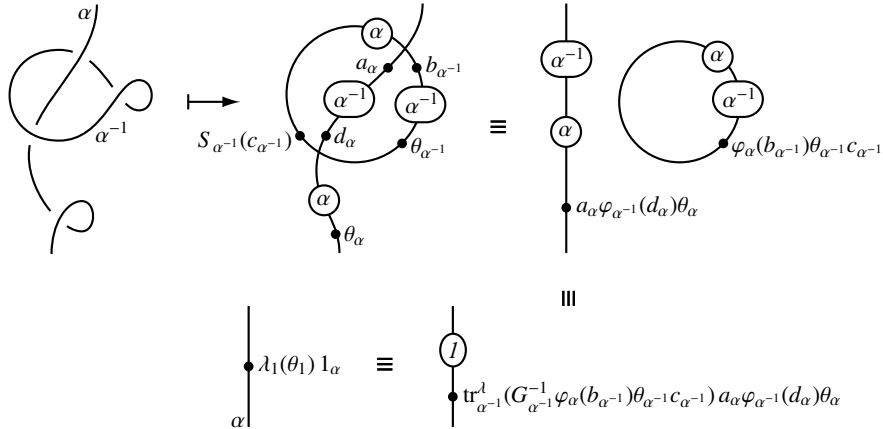
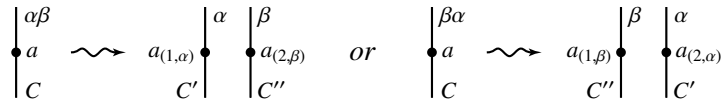
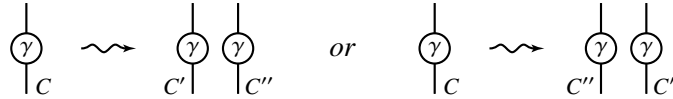

FIGURE 4.19.

(b) a segment of C containing some algebraic element is split as follows:



(c) a segment of C containing a labelled disc is split as follows:



Moreover, these splitting rules are compatible with the rules of Figure 4.5.

Proof. Fix a crossing c of the π -colored tangle diagram $K_{\alpha_1, \dots, \alpha_n, \alpha_{n+1}}$. We have to consider three cases: any, one, or two strands of the crossing c is part of the component C . Firstly, if any of the two strands of c belongs to C , then c remains unchanged in $K_{\alpha_1, \dots, \alpha_n, \alpha_{n+1}}$. Suppose secondly that only one strand of c is part of C . There is height cases to consider (depending of the type of the crossing, the position of C in c , and the relative position of C' and C'' in $K_{\alpha_1, \dots, \alpha_n, \alpha_{n+1}}$). For example, if the position of C in c is from bottom-left to upper-right, the four cases are depicted in Figure 4.20.

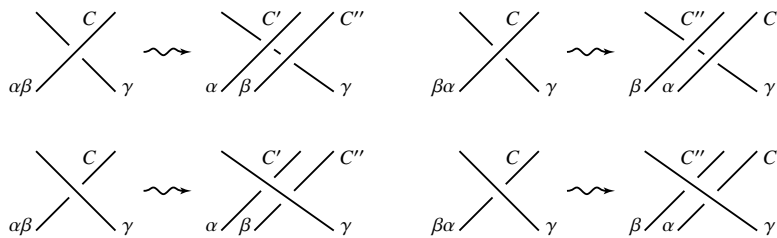

FIGURE 4.20.

The compatibility of the splitting rules with Step (B) of Section 4.1.4 follows from the quasi-triangularity of Hopf π -coalgebra H . For example, for the first case of Figure 4.20, if we write

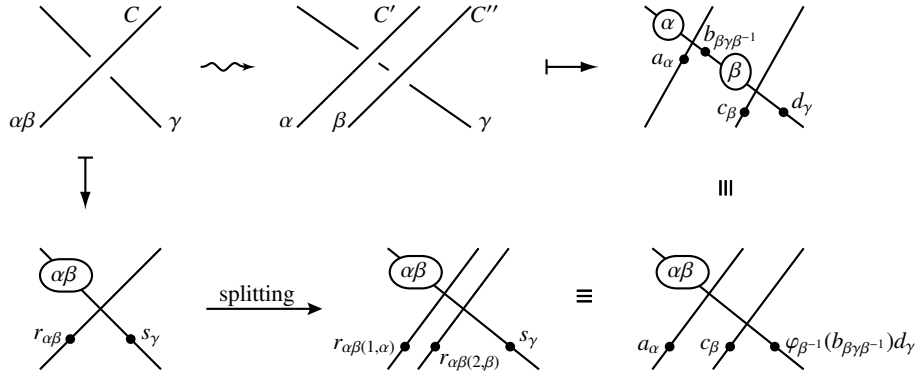
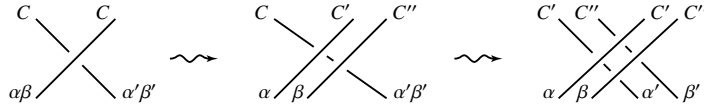

FIGURE 4.21.

$R_{\alpha\beta,\gamma} = r_{\alpha\beta} \otimes s_\gamma$, $R_{\alpha,\beta\gamma\beta^{-1}} = a_\alpha \otimes b_{\beta\gamma\beta^{-1}}$, and $R_{\beta,\gamma} = c_\beta \otimes d_\gamma$, then

$$r_{\alpha\beta(1,\alpha)} \otimes r_{\alpha\beta(2,\beta)} \otimes s_\gamma = a_\alpha \otimes c_\beta \otimes \varphi_{\beta^{-1}}(b_{\beta\gamma\beta^{-1}})d_\gamma \quad \text{by (2.6)}$$

and so the diagram of Figure 4.21 is commutative. The others cases of Figure 4.20 can be done similarly. Suppose thirdly that the two strands of c are part of C . There is also height cases to consider (depending of the type of the crossing and the relative positions of C' and C''). Here the compatibility with the splitting can be formally done by decomposing through the previous case. For example:



Finally, the compatibility of the splitting rules with the ones of Figure 4.5 comes from the anti-(co)multiplicativity of the antipode S and the (co)multiplicativity of the crossing φ . For example, let $\alpha, \beta, \gamma \in \pi$ and $a, b \in H_{\alpha\beta}$. Since $S_{\alpha\beta}(a)_{(1,\beta^{-1})} \otimes S_{\alpha\beta}(a)_{(2,\alpha^{-1})} = S_\beta(a_{(2,\beta)}) \otimes S_\alpha(a_{(1,\alpha)})$ by Lemma 1.1(c), $(ab)_{(1,\alpha)} \otimes (ab)_{(2,\beta)} = a_{(1,\alpha)}b_{(1,\alpha)} \otimes a_{(2,\beta)}b_{(2,\beta)}$ by (1.4), and $\varphi_\gamma(a_{(1,\alpha)}) \otimes \varphi_\gamma(a_{(2,\beta)}) = \varphi_\gamma(a)_{(1,\alpha)} \otimes \varphi_\gamma(a)_{(2,\beta)}$ by (2.2), the diagrams of Figure 4.22 are commutative. \square

4.2.5. Basic properties of τ_H . Throughout this subsection H will denote a finite type unimodular ribbon Hopf π -coalgebra and $\lambda = (\lambda_\alpha)_{\alpha \in \pi}$ a right π -integral for H such that $\lambda_1(\theta_1) \neq 0$ and $\lambda_1(\theta_1^{-1}) \neq 0$, where $\theta = \{\theta_\alpha\}_{\alpha \in \pi}$ denotes the twist of H .

Let (M_1, ξ_1) and (M_2, ξ_2) be two π -manifolds. Choosing base points of their total spaces leads to two pointed π -manifolds (M_1, x_1, f_1) and (M_2, x_2, f_2) . Take closed 3-balls $B_1 \subset M_1$ and $B_2 \subset M_2$ such that $x_1 \in \partial B_1$ and $x_2 \in \partial B_2$. Glue $M_1 \setminus \text{Int}B_1$ and $M_2 \setminus \text{Int}B_2$ along a homeomorphism $h : \partial B_1 \rightarrow \partial B_2$ chosen so that $h(x_1) = x_2$ and that the orientations in $M_1 \setminus \text{Int}B_1$ and $M_2 \setminus \text{Int}B_2$ induced by those in M_1, M_2 are compatible. This gluing yields a closed, connected, and oriented 3-manifold $M_1 \# M_2$ endowed with a base point $x = h(x_1) = x_2$. By the Van Kampen theorem, since $\partial B_2 \cong h(\partial B_1)$ is simply-connected, there exists an unique group homomorphism $f : \pi_1(M_1 \# M_2, x) \rightarrow \pi$ such that the diagram of Figure 4.23(a) is commutative, where the horizontal arrows are induced by the embeddings $(M_1, x_1) \hookrightarrow (M_1 \# M_2, x)$ and $(M_2, x_2) \hookrightarrow (M_1 \# M_2, x)$. We denote by $(M_1 \# M_2, \xi_1 \# \xi_2)$ the underlying π -manifold of the pointed π -manifold $(M_1 \# M_2, x, f)$.

LEMMA 4.16. $\tau_H(M_1 \# M_2, \xi_1 \# \xi_2) = \tau_H(M_1, \xi_1) \tau_H(M_2, \xi_2)$.

Proof. Let (L_1, z_1, g_1) and (L_2, z_2, g_2) be two π -links along which (M_1, x_1, f_1) and (M_2, x_2, f_2) are respectively obtained from S^3 by surgery. Without loss of generality, we can suppose that

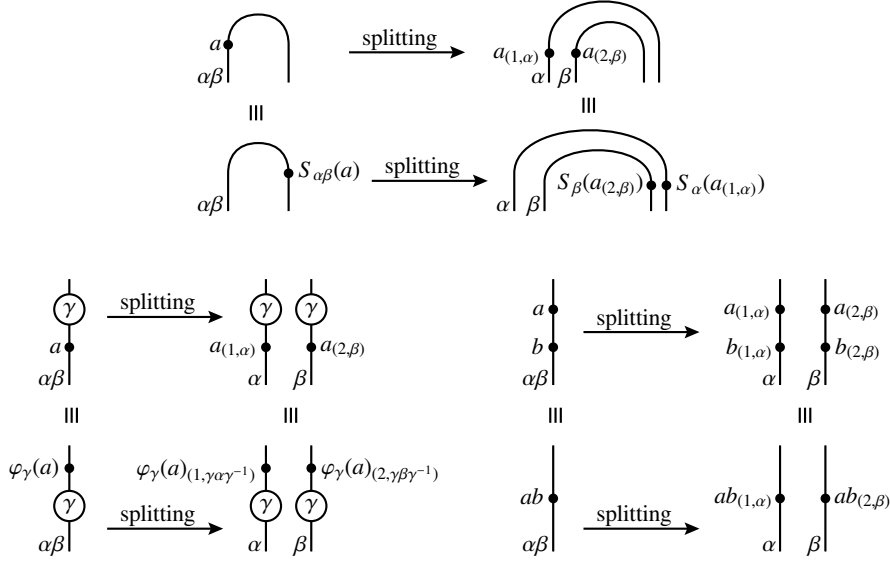

FIGURE 4.22.

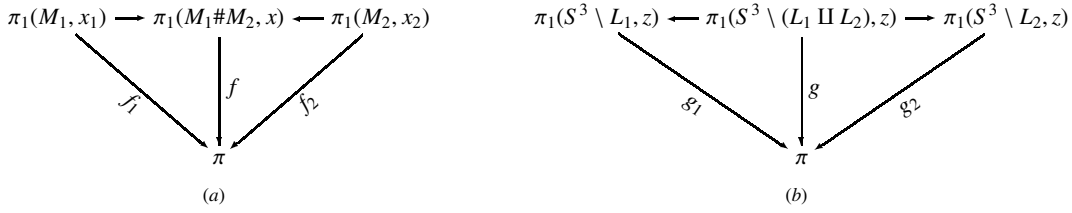

FIGURE 4.23.

L_1 and L_2 are disjoint (in S^3) and that $z_1 = z_2$. Set $z = z_1 = z_2$ and let $\omega_i : \pi_1(S^3 \setminus L_i, z) \rightarrow \pi_1(S^3 \setminus L_1 \amalg L_2, z)$. As in Lemma 4.6, there exists a unique group homomorphism $g : \pi_1(S^3 \setminus L_1 \amalg L_2, z) \rightarrow \pi$ such that the diagram of Figure 4.23(b) is commutative, where the horizontal arrows are induced by the embeddings $(S^3 \setminus L_1 \amalg L_2, z) \hookrightarrow (S^3 \setminus L_1, z)$ and $(S^3 \setminus L_1 \amalg L_2, z) \hookrightarrow (S^3 \setminus L_2, z)$. Then $(L_1 \amalg L_2, z, g)$ is a π -link along which $(M_1 \# M_2, x, f)$ is obtained from S^3 by surgery. One easily concludes using the facts that $b_-(L_1 \amalg L_2) = b_-(L_1) + b_-(L_2)$, $n_{L_1 \amalg L_2} = n_{L_1} + n_{L_2}$, and $\text{Inv}_{\{H, \text{tr}\}}(L_1 \amalg L_2, z, g) = \text{Inv}_{\{H, \text{tr}\}}(L_1, z, g_1) \text{Inv}_{\{H, \text{tr}\}}(L_2, z, g_2)$ (by Lemma 4.6). \square

Let (M, ξ) be a π -manifold. Let H^{cop} be the ribbon Hopf π -coalgebra copposite to H . It is endowed with a right π -integral $\lambda^{\text{cop}} = (\lambda_{\alpha^{-1}})_{\alpha \in \pi}$ such that $\lambda_1^{\text{cop}}(\theta_1^{\text{cop}}) \neq 0$ and $\lambda_1^{\text{cop}}(\theta_1^{\text{cop}-1}) \neq 0$. Denote by $-M$ the manifold M with the opposite orientation.

LEMMA 4.17. $\tau_H(-M, \xi) = (\lambda_1(\theta_1^{-1})/\lambda_1(\theta_1))^{b_1(M)} \tau_{H^{\text{cop}}}(M, \xi)$, where $b_1(M)$ is the first Betti number of the 3-manifold M .

Proof. Choosing a base point of in total space of ξ leads to a pointed π -manifold (M, x, f) . Let (L, z, g) be a π -link along which (M, x, f) and is obtained from S^3 by surgery. There exists an orientation-preserving homeomorphism $h : S^3_L \rightarrow M$ such that $i_L(z) = h^{-1}(x)$ and $g = f \circ h_* \circ (i_L)_*$. Let ρ be an orientation-reversing homeomorphism of S^3 . It induces an orientation-reversing

homeomorphism $\bar{\rho} : S_L^3 \rightarrow S_{\rho(L)}^3$ such that $i_{\rho(L)} \circ \rho|_{S^3 \setminus L} = \bar{\rho} \circ i_L$. Since $h \circ \bar{\rho}^{-1} : S_{\rho(L)}^3 \rightarrow -M$ is an orientation-preserving homeomorphism such that $i_{\rho(L)}(\rho(z)) = (h \circ \bar{\rho}^{-1})(x)$ and $g \circ \rho_*^{-1} = f \circ (h \circ \bar{\rho}^{-1})_* \circ (i_{\rho(L)})_*$, the pointed π -manifold $(-M, x, f)$ is obtained from S^3 by surgery along the π -link $(\rho(L), \rho(z), g \circ \rho_*^{-1})$. Since $\theta_1^{\text{cop}} = \theta_1^{-1}$, $b_-(\rho(L)) = n_L - b_-(L) - b_1(M)$, and $n_{\rho(L)} = n_L$, we have that

$$\lambda_1(\theta_1)^{b_-(\rho(L)) - n_{\rho(L)}} \lambda_1(\theta_1^{-1})^{-b_-(\rho(L))} = (\lambda_1(\theta_1^{-1}) / \lambda_1(\theta_1))^{b_1(M)} \lambda_1^{\text{cop}}(\theta_1^{\text{cop}})^{b_-(L) - n_L} \lambda_1^{\text{cop}}((\theta_1^{\text{cop}})^{-1})^{-b_-(L)}.$$

We conclude by using $\text{Inv}_{\{H, \text{tr}\}}(\rho(L), \rho(z), g \circ \rho_*^{-1}) = \text{Inv}_{\{H^{\text{cop}}, \text{tr}^{\text{cop}}\}}(L, z, g)$ (see Lemma 4.7). \square

4.3. Comparison with the Turaev invariant

In this section, we compare the invariant of π -manifolds constructed in Section 4.2 with the Turaev invariant of π -manifolds defined in [48].

4.3.1. Modular π -categories. Let $\mathcal{C} = \coprod_{\alpha \in \pi} \mathcal{C}_\alpha$ be a premodular π -category. In particular the set J_1 of isomorphism classes of simple objects of \mathcal{C}_1 is finite. For $i, j \in J_1$, choose simple objects $V_i^1, V_j^1 \in \mathcal{C}_1$ representing i, j , respectively, and set

$$S_{i,j} = \text{tr}(c_{V_j^1, V_i^1} \circ c_{V_i^1, V_j^1} : V_i^1 \otimes V_j^1 \rightarrow V_j^1 \otimes V_i^1) \in \text{End}_{\mathcal{C}}(\mathbb{1}) = \mathbb{k}.$$

It follows from the properties of the quantum trace that $S_{i,j}$ does not depend on the choice of V_i^1 and V_j^1 . Following [48], we say that the premodular π -category \mathcal{C} is *modular* if

(4.9) the square matrix $S = [S_{i,j}]_{i,j \in J_1}$ is invertible over \mathbb{k} .

The neutral component \mathcal{C}_1 of \mathcal{C} is a modular category in the sense of [47] (remark that (4.9) involves only \mathcal{C}_1).

Let $\mathcal{C} = \coprod_{\alpha \in \pi} \mathcal{C}_\alpha$ be a modular π -category and let $\{V_j^1\}_{j \in J_1}$ be a representative set of the isomorphism classes of simple objects of \mathcal{C}_1 . A *rank* of \mathcal{C}_1 is an element $D \in \mathbb{k}$ such that

$$D^2 = \sum_{j \in J_1} \dim(V_j^1)^2 \in \mathbb{k}.$$

Since each $V_j^1 \in \mathcal{C}_1$ is a simple object, the twist $\theta_{V_j^1} : V_j^1 \rightarrow \varphi_1(V_j^1) = V_j^1$ equals $v_j \text{id}_{V_j^1}$ for some $v_j \in \mathbb{k}$. Since $\theta_{V_j^1}$ is invertible, $v_j \in \mathbb{k}^*$. Set

$$(4.10) \quad \Delta_{\pm} = \sum_{j \in J_1} v_j^{\pm 1} \dim(V_j^1)^2 \in \mathbb{k}.$$

It is known (see [47, §II.2.4]) that D and Δ_{\pm} are invertible in \mathbb{k} and that

$$(4.11) \quad \Delta_+ \Delta_- = D^2.$$

4.3.2. The Turaev invariant of π -manifolds. Fix a modular π -category $\mathcal{C} = \coprod_{\alpha \in \pi} \mathcal{C}_\alpha$ endowed with a rank D and set Δ_- as in (4.10). Let (M, ξ) be a π -manifold. Choose a base point \tilde{x} in the total space \tilde{M} . Denote by x be the projection of \tilde{x} under the covering $\tilde{M} \rightarrow M$ and by $f : \pi_1(M, x) \rightarrow \pi$ the monodromy of ξ at \tilde{x} . Present the pointed π -manifold (M, x, f) by a surgery of S^3 along a π -link $(L = L_1 \sqcup \cdots \sqcup L_n, z, g)$ (see Lemma 4.10). Choose an orientation for L . For each $1 \leq i \leq n$, choose a path $\gamma_i : [0, 1] \rightarrow S^3 \setminus L$ such that $\gamma_i(0) = z$ and $\gamma_i(1) \in \tilde{L}_i$ and set

$$\alpha_i = g([\gamma_i^{-1} m_i \gamma_i]) \in \pi,$$

where m_i is a small loop encircling L_i with linking number $+1$.

Consider a generic diagram D_L of L such that the base point z corresponds to the eyes of the reader (see §4.1.2). For any objects $X_1 \in \mathcal{C}_{\alpha_1}, \dots, X_n \in \mathcal{C}_{\alpha_n}$, we denote by $F(D_L; X_1, \dots, X_n) \in$

$\text{End}(\mathbb{1}) = \mathbb{k}$ the morphism in C_1 obtained in the following way: for each $1 \leq i \leq n$, label the connected component of D_L corresponding to $\gamma_i(1)$ by the object X_i . Since the longitudes of L are sent to $1 \in \pi$ by g (see the proof of Lemma 4.11), all the other connected components of D_L can be uniquely labelled by following the rules of the graphical calculus (see Section 3.1.7) in order to obtain a diagram of a morphism in C (see [48, LEMMA 3.2.1]). This morphism only depends on the isotopy class of L and is denoted by $F(D_L; X_1, \dots, X_n)$.

The Turaev invariant of the π -manifold (M, ξ) is

$$\mathcal{T}_{(C,D)}(M, \xi) = \Delta_-^{\sigma(L)} D^{-\sigma(L)-n-1} \sum_{j_1 \in J_{\alpha_1}, \dots, j_n \in J_{\alpha_n}} \left(\prod_{i=1}^n \dim_q(V_{j_i}^{\alpha_i}) \right) F(D_L; V_{j_1}^{\alpha_1}, \dots, V_{j_n}^{\alpha_n}) \in \mathbb{k},$$

where $\sigma(L)$ is the signature of the linking matrix of L and each $\{V_j^\alpha\}_{j \in J_\alpha}$ is a representative (finite) set of the isomorphism classes of simple objects of C_α .

We now give another expression of this invariant, more suitable to our needs, by using the factorization properties of the coends. Without loss of generality (by isotoping the segments of D_L corresponding to the $\gamma_i(1)$, see Figure 4.24(a)), we can assume that the (directed) diagram D_L is of the form $D_L = D_L^{\text{split}} \circ C_n$ where:

- D_L^{split} is a tangle with $2n$ inputs, no outputs, and no circle component (see Figure 4.24(b));
- C_n is the tangle with no inputs and $2n$ outputs which is formed by n cups directed from right to left (see Figure 4.24(c)) and such that the i^{th} cup belongs to the connected component of D_L corresponding to $\gamma_i(1)$.

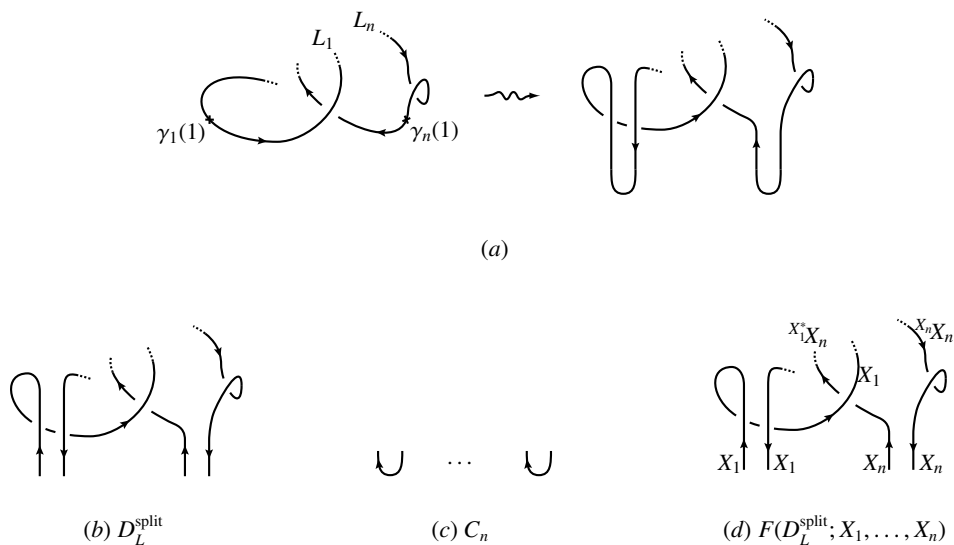

FIGURE 4.24.

Recall that, for each $\alpha \in \pi$, by Lemma 3.11, the functor $F_\alpha : C_\alpha^{\text{op}} \times C_\alpha \rightarrow C_1$, defined as in (3.33), has a coend $\langle B_\alpha, i' : F_\alpha \dashrightarrow B_\alpha \rangle$. For any objects $X_1 \in C_{\alpha_1}, \dots, X_n \in C_{\alpha_n}$, by labelling the $(2i - 1)^{\text{th}}$ and $2i^{\text{th}}$ input strings of D_L^{split} with X_i (for $1 \leq i \leq n$) as in Figure 4.24(d), we obtain a diagram which represents a morphism

$$F(D_L^{\text{split}}; X_1, \dots, X_n) : X_1^* \otimes X_1 \otimes \dots \otimes X_n^* \otimes X_n \rightarrow \mathbb{1}.$$

By using the naturality of the duality, the braiding, and the twist (see Sect. 3.1), the function $(X_1, \dots, X_n) \mapsto F(D_L^{\text{split}}; X_1, \dots, X_n)$ verifies the hypothesis of Corollary 3.3. Hence there exists a unique morphism

$$T_{D_L^{\text{split}}} : B_{\alpha_1} \otimes \cdots \otimes B_{\alpha_n} \rightarrow \mathbb{1}$$

such that $F(D_L^{\text{split}}; X_1, \dots, X_n) = T_{D_L^{\text{split}}} \circ (i'_{X_1} \otimes \cdots \otimes i'_{X_n})$ for all objects $X_1 \in C_{\alpha_1}, \dots, X_n \in C_{\alpha_n}$.

For any $\alpha \in \pi$, define $\mu^{\text{semi}} = (\mu_\alpha^{\text{semi}})_{\alpha \in \pi}$ by

$$(4.12) \quad \mu_\alpha^{\text{semi}} = \sum_{j \in J_\alpha} \dim_q(V_j^\alpha) i'_{V_j^\alpha} \circ \widetilde{\text{coev}}_{V_j^\alpha} : \mathbb{1} \rightarrow B_\alpha,$$

where $\{V_j^\alpha\}_{j \in J_\alpha}$ is a representative set of the (finite) set J_α of isomorphic classes of simple objects of C_α . Then the Turaev invariant of (M, ξ) (calculated from the π -category C) can be rewritten as

$$(4.13) \quad \mathcal{T}_{(C,D)}(M, \xi) = \Delta_-^{\sigma(L)} D^{-\sigma(L)-n-1} T_{D_L^{\text{split}}} \circ (\mu_{\alpha_1}^{\text{semi}} \otimes \cdots \otimes \mu_{\alpha_n}^{\text{semi}}).$$

4.3.3. Comparison of $\mathcal{T}_{\text{Rep}(H)}$ with τ_H . Let $H = \{H_\alpha\}_{\alpha \in \pi}$ be a finite type ribbon Hopf π -coalgebra. When the category of representations $\text{Rep}(H)$ of H is modular, the Turaev invariant $\mathcal{T}_{\text{Rep}(H)}$ of π -manifolds is well-defined. Recall (see Theorem 4.12) that the invariant τ_H of π -manifolds constructed in Section 4.2 is well-defined provided H is moreover unimodular and $\lambda_1(\theta_1) \neq 0$ and $\lambda_1(\theta_1^{-1}) \neq 0$ for at least one (and thus all) non-zero right π -integral $\lambda = (\lambda_\alpha)_{\alpha \in \pi}$ for H . In the next theorem, we compare $\mathcal{T}_{(\text{Rep}(H), D)}$ with τ_H .

THEOREM 4.18. *Let H be a finite-type unimodular ribbon Hopf π -coalgebra such that its category of representations $\text{Rep}(H)$ is modular. Let D be a rank of $\text{Rep}(H)$ and set Δ_- as in (4.10). Then the invariant τ_H constructed in Section 4.2 is well-defined and is related to the Turaev invariant $\mathcal{T}_{(\text{Rep}(H), D)}$ by*

$$\mathcal{T}_{(\text{Rep}(H), D)}(M, \xi) = D^{-1} \left(\frac{D}{\Delta_-} \right)^{b_1(M)} \tau_H(M, \xi)$$

for any π -manifold (M, ξ) , where $b_1(M)$ is the first Betti number of the 3-manifold M .

The theorem is proved in the next subsection.

Theorem 4.18 generalizes [18, THEOREM 1] where this result is shown for $\pi = 1$ and H is a (usual) quantum double of a Hopf algebra (note that such a double is always unimodular).

In general, the π -category $\text{Rep}(H)$ of representations of a finite type ribbon Hopf π -coalgebra H is not modular. Nevertheless, a modular π -category C_H may often be derived from $\text{Rep}(H)$ (see [5]). In that case, the invariant $\mathcal{T}_{(C_H, D)}$ and τ_H are not necessarily related one to the other (this was shown in the case $\pi = 1$ in [17]).

4.3.4. Proof of Theorem 4.18. We use the notation of Section 4.3.2, except that we replace the π -category C with $\text{Rep}(H)$. Recall that (M, ξ) denotes a π -manifold, that a base point in the total space of ξ is chosen, that the so-obtained pointed π -manifold is presented by a surgery of S^3 along a π -link $(L = L_1 \sqcup \cdots \sqcup L_n, z, g)$, that L is arbitrarily oriented, and that a path $\gamma_i : [0, 1] \rightarrow S^3 \setminus L$ such that $\gamma_i(0) = z$ and $\gamma_i(1) \in \tilde{L}_i$ is chosen for each $1 \leq i \leq n$. This leads to $\alpha_i = g([\gamma_i^{-1} m_i \gamma_i]) \in \pi$, where m_i is a small loop encircling L_i with linking number $+1$. Moreover we have a diagram D_L of L which is oriented, whose each connected component is provided with an object of $\text{Rep}(H)$, and which is of the form $D_L = D_L^{\text{split}} \circ C_n$ where:

- D_L^{split} is a tangle with $2n$ inputs, no outputs, and no circle component (see Figure 4.24(b));
- C_n is the tangle with no inputs and $2n$ outputs which is formed by n cups directed from right to left (see Figure 4.24(c)) and such that the i^{th} cup belongs to the connected component of D_L corresponding to $\gamma_i(1)$.

We first remark that, given any $M_1 \in \text{Rep}_{\alpha_1}(H), \dots, M_n \in \text{Rep}_{\alpha_n}(H)$, we can read the π -coloration (in the sense of §4.1.2) of D_L from the (oriented) diagram $D_L(M_1, \dots, M_n)$ which represents the morphism $F(D_L; M_1, \dots, M_n)$. Indeed let ℓ be a connected component of D_L , that is, a segment of D_L delimited by under-crossings. The corresponding segment in $D_L(M_1, \dots, M_n)$ is oriented and is provided with an object $M \in \text{Rep}_{\alpha}(H)$ for some $\alpha \in \pi$. Cut ℓ at its extremal points (with respect to the height function) to obtain vertical segments (in the sense of §4.1.2) which are directed. Then the π -color of such a vertical segment is α (resp. α^{-1}) when its orientation is downwards (resp. upwards), since if μ represents a loop that, starting from the base point z (the eyes of the reader) above the diagram D_L , goes straight to the vertical segment, encircles it from left to right, and returns immediately to the base point (see Figure 4.3), then the linking number of μ with the considered vertical segment is $+1$ (resp. -1) if the vertical segment is oriented downwards (resp. upwards).

The π -coloration of the link diagram D_L induces a π -coloration of the tangle diagram D_L^{split} . In particular the vertical segment corresponding to the $(2i)^{\text{th}}$ input of D_L^{split} is colored by α_i and the vertical segment corresponding to the $(2i - 1)^{\text{th}}$ input of D_L^{split} is colored by α_i^{-1} , see Figure 4.25.

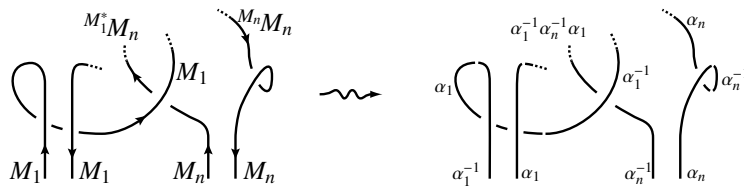

FIGURE 4.25.

Since the diagram D_L^{split} does not have any circle component, by applying Step (B) of Section 4.1.4 and then the rules of Figures 4.5, 4.6, and 4.7 to the π -colored tangle diagram D_L^{split} (see Figure 4.26), we obtain that there exists a unique

$$a_L^{\text{split}} = \sum_l a_l^1 \otimes \dots \otimes a_l^n \in H_{\alpha_1} \otimes \dots \otimes H_{\alpha_n}$$

such that the flat diagram of D_L^{split} is equivalent to the one depicted in Figure 4.27.

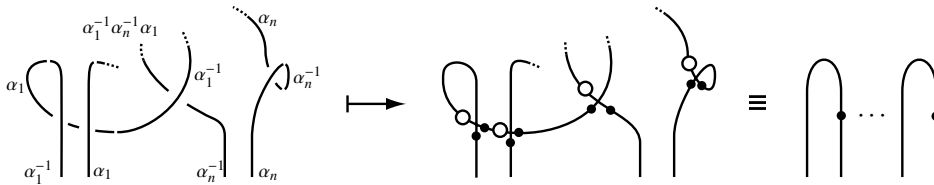

FIGURE 4.26.

LEMMA 4.19. For any $M_1 \in \text{Rep}_1(H), \dots, M_n \in \text{Rep}_n(H)$, we have

$$F(D_L^{\text{split}}; M_1, \dots, M_n) = \sum_l \text{ev}_{M_1}(\text{id}_{M_1^*} \otimes a_l^1 \cdot \text{id}_{M_1}) \otimes \dots \otimes \text{ev}_{M_n}(\text{id}_{M_n^*} \otimes a_l^n \cdot \text{id}_{M_n}).$$

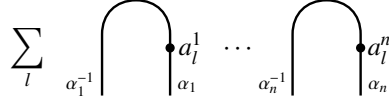

FIGURE 4.27.

Proof. The flat diagram $(D_L^{\text{split}})_{\text{flat}}$ of the π -colored tangle D_L^{split} obtained just after applying Step (B) inherits an orientation and a $\text{Rep}(H)$ -coloration from the diagram of the morphism $F(D_L^{\text{split}}; M_1, \dots, M_n) : M_1 \otimes \dots \otimes M_n \rightarrow \mathbb{k}$. Indeed, each segment of $(D_L^{\text{split}})_{\text{flat}}$ delimited by discs labelled with elements of π (which are in one-to-one correspondence with under-crossings) is directed and endowed with an object of $\text{Rep}(H)$. See, for example, Figure 4.28 where $V \in \text{Rep}_\alpha(H)$, $W \in \text{Rep}_\beta(H)$, and $R_{\alpha, \beta^{-1}} = a_\alpha \otimes b_{\beta^{-1}}$.

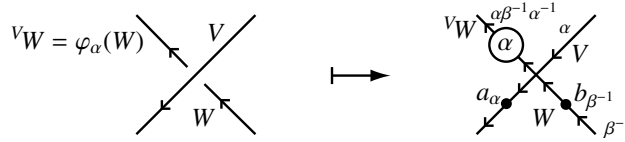

FIGURE 4.28.

Let us associate to $(D_L^{\text{split}})_{\text{flat}}$ a \mathbb{k} -linear morphism $\xi_{M_1, \dots, M_n} : M_1 \otimes \dots \otimes M_n \rightarrow \mathbb{k}$ defined in the following way:

- to a diagram as in Figure 4.29(a), where $\alpha \in \pi$, $M \in \text{Rep}_\alpha(H)$, and $a \in H_\alpha$, we associate the morphism $\phi_a^M = a \cdot \text{id}_M : M \rightarrow M$;
- to a diagram as in Figure 4.29(b), where $\alpha \in \pi$, $M \in \text{Rep}_\alpha(H)$, and $b \in H_{\alpha^{-1}}$, we associate the morphism $\phi_b^{M^*} = b \cdot \text{id}_{M^*} : M^* \rightarrow M^*$;
- to diagrams as in Figure 4.29(c), where $\alpha, \beta \in \pi$, $V \in \text{Rep}_\alpha(H)$, and $W \in \text{Rep}_\beta(H)$, we associate the flip maps $\sigma_{V, W}$, σ_{V, W^*} , $\sigma_{V^*, W}$, and σ_{V^*, W^*} respectively;
- to a diagram as in Figure 4.29(d), where $\alpha, \beta \in \pi$ and $M \in \text{Rep}_\alpha(H)$, we associate the isomorphism $\varphi_\beta^M : M \rightarrow \varphi_\beta(M)$ which comes from the fact that $M = \varphi_\beta(M)$ as \mathbb{k} -spaces (see Section 3.1.8). Note that in fact $\varphi_\beta^M = \text{id}_M$ but this notation allows us to keep in mind that $a \cdot \varphi_\beta^M(m) = \varphi_\beta^M(\varphi_{\beta^{-1}}(a) \cdot m)$ for any $a \in H_{\beta\alpha\beta^{-1}}$ and $m \in M$;
- to a diagram as in Figure 4.29(e), where $\alpha, \beta \in \pi$ and $M \in \text{Rep}_\alpha(H)$, we associate the isomorphism $\varphi_\beta^{M^*} : M^* \rightarrow \varphi_\beta(M^*) = \varphi_\beta(M)^*$;
- to diagrams as in Figure 4.29(f), where $\alpha \in \pi$ and $M \in \text{Rep}_\alpha(H)$, we associate the duality morphisms ev_M , $\widetilde{\text{ev}}_M$, coev_M , and $\widetilde{\text{coev}}_M$ respectively.

Then we compose these associated morphisms in a similar way we compose the morphisms represented by tangles to obtain ξ_{M_1, \dots, M_n} .

Now remark that the rules of Figures 4.5, 4.6, and 4.7 used to concentrate the algebraic decoloration of a flat diagram are compatible with the above construction of ξ_{M_1, \dots, M_n} . For example, given $M \in \text{Rep}_\alpha(H)$, the rule described in Figure 4.30(a), where $a, b \in H_\alpha$, corresponds to the relation $\phi_a^M \circ \phi_b^M = \phi_{ab}^M$ which is verified (by the definition of a left action). The rule described in Figure 4.30(b), where $a \in H_{\alpha^{-1}}$, corresponds to the relation $\text{ev}_M(\phi_a^{M^*} \otimes \text{id}_M) = \text{ev}_M(\text{id}_{M^*} \otimes \phi_{S_{\alpha^{-1}}(a)}^M)$ which comes from the fact that a acts on M^* as the transpose of $x \in M \mapsto S_{\alpha^{-1}}(a) \cdot x \in M$. The rule described in Figure 4.30(c), where $a \in H_\alpha$, corresponds to the relation $\phi_{\varphi_\beta(a)}^{\varphi_\beta(M)} \varphi_\beta^M = \varphi_\beta^M \phi_a^M$

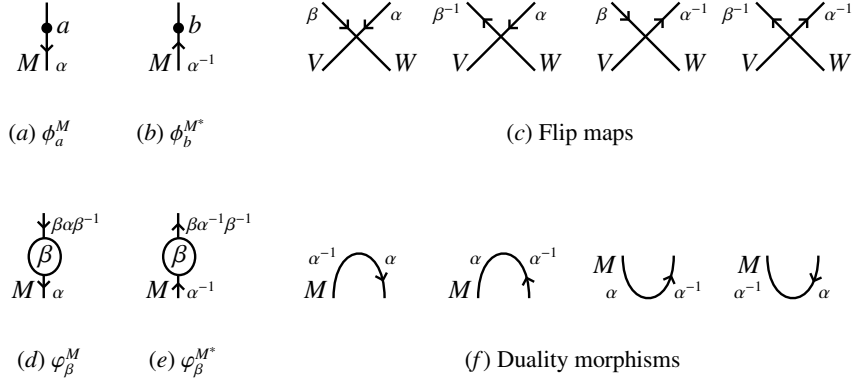

FIGURE 4.29.

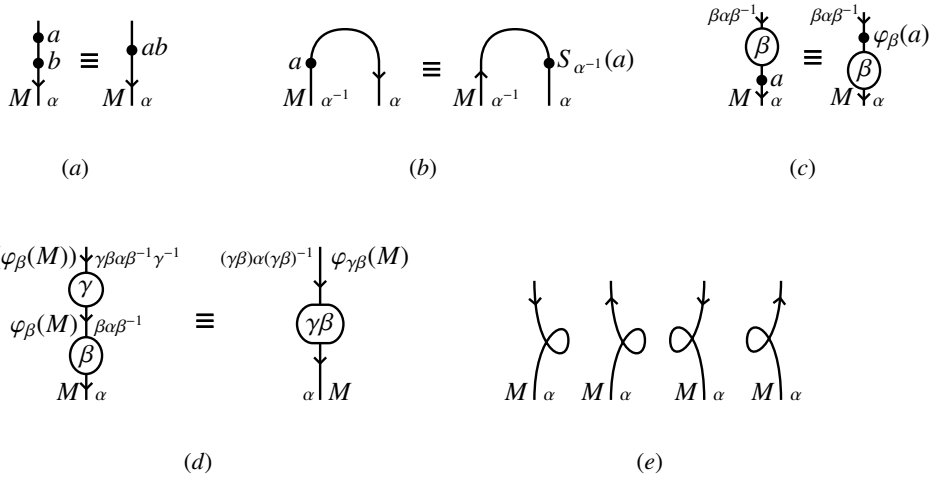

FIGURE 4.30.

which follows from the definition of the action of $H_{\beta\alpha\beta^{-1}}$ on $\varphi_\beta(M)$. The rule described in Figure 4.30(d) corresponds to the relation $\varphi_\gamma^{\varphi_\beta(M)} \circ \varphi_\beta^M = \varphi_{\gamma\beta}^M$ which comes from (2.4). Note also that the morphisms corresponding the curls depicted in Figure 4.30(e) can be replaced by $\phi_{G_\alpha}^M$, $\phi_{G_\alpha}^{M^*}$, $\phi_{G_\alpha^{-1}}^M$, and $\phi_{G_\alpha^{-1}}^{M^*}$ respectively (see Figure 4.6).

Therefore the morphism ξ_{M_1, \dots, M_n} can be expressed from the flat diagram depicted in Figure 4.27, that is,

$$\xi_{M_1, \dots, M_n} = \sum_l \text{ev}_{M_1}(\text{id}_{M_1^*} \otimes a_l^1 \text{id}_{M_1}) \otimes \dots \otimes \text{ev}_{M_n}(\text{id}_{M_n^*} \otimes a_l^n \text{id}_{M_n}).$$

To prove the lemma, it remains to verify that $F(D_L^{\text{split}}; M_1, \dots, M_n) = \xi_{M_1, \dots, M_n}$. This follows from the fact that the above procedure to construct ξ_{M_1, \dots, M_n} from the flat diagram $(D_L^{\text{split}})_{\text{flat}}$ agrees with the graphical calculus used to determine $F(D_L^{\text{split}}; M_1, \dots, M_n)$. It is clear for cup-like or

cap-like arcs. For crossings let $\alpha, \beta \in \pi$, $V \in \text{Rep}_\alpha(H)$, and $W \in \text{Rep}_\beta(H)$. Write $R_{\alpha, \beta} = a_\alpha \otimes b_\beta$ and $R_{\beta^{-1}, \alpha} = c_{\beta^{-1}} \otimes d_\alpha$. Then

$$\begin{aligned} R_{\beta, \beta^{-1}, \alpha, \beta} &= (S_{\beta^{-1}} \varphi_\beta \otimes \text{id}_{H_{\beta^{-1}, \alpha}})(R_{\beta^{-1}, \beta^{-1}, \alpha, \beta}) \quad \text{by Lemma 2.4(b)} \\ &= (S_{\beta^{-1}} \otimes \varphi_{\beta^{-1}})(\varphi_\beta \otimes \varphi_\beta)(R_{\beta^{-1}, \beta^{-1}, \alpha, \beta}) \quad \text{by (2.4)} \\ &= (S_{\beta^{-1}} \otimes \varphi_{\beta^{-1}})(R_{\beta^{-1}, \alpha}) \quad \text{by (2.7)} \\ &= S_{\beta^{-1}}(c_{\beta^{-1}}) \otimes \varphi_{\beta^{-1}}(d_\alpha). \end{aligned}$$

and so, using the definition of a braiding in a π -category of representation (§3.1.8), we have that

$$c_{V, W} = (\varphi_\alpha^W \otimes \text{id}_V) \circ \sigma_{V, W} \circ (\phi_{a_\alpha}^V \otimes \phi_{b_\beta}^W)$$

and

$$\begin{aligned} c_{W, W^*V}^{-1} &= (\phi_{S_{\beta^{-1}}(c_{\beta^{-1}})}^W \otimes \phi_{\varphi_{\beta^{-1}}(d_\alpha)}) \circ \sigma_{W, W^*V}^{-1} \circ (\varphi_\beta^{W^*V} \otimes \text{id}_V)^{-1} \\ &= (\phi_{S_{\beta^{-1}}(c_{\beta^{-1}})}^W \otimes \phi_{\varphi_{\beta^{-1}}(d_\alpha)}) \circ \sigma_{W^*V, W} \circ (\varphi_{\beta^{-1}}^V \otimes \text{id}_V) \\ &= (\phi_{S_{\beta^{-1}}(c_{\beta^{-1}})}^W \otimes \phi_{\varphi_{\beta^{-1}}(d_\alpha)}) \circ (\text{id}_W \otimes \varphi_{\beta^{-1}}^V) \circ \sigma_{V, W} \\ &= (\text{id}_W \otimes \varphi_{\beta^{-1}}^V) \circ (\phi_{S_{\beta^{-1}}(c_{\beta^{-1}})}^W \otimes \phi_{d_\alpha}^V) \circ \sigma_{V, W}. \end{aligned}$$

Hence the morphism associated to a crossing using above procedure agrees with the representation of a braiding in graphical calculus, see Figure 4.31. This completes the proof of the lemma. \square

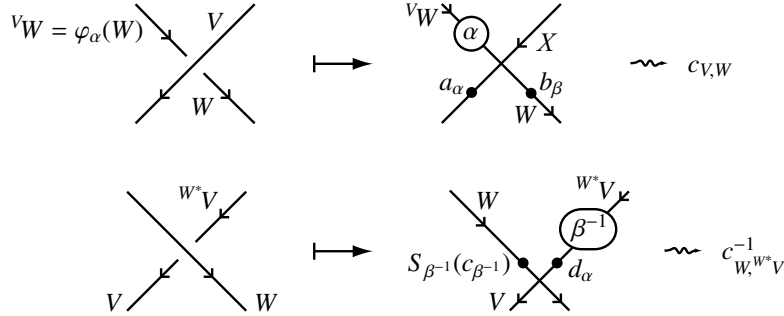

FIGURE 4.31.

Let $\langle A_\alpha, i : F_\alpha \dashrightarrow A_\alpha \rangle$ be the coend of the functor F_α as in Section 3.4.1 (recall $A_\alpha = H_\alpha^*$ as \mathbb{k} -space) and $\langle B_\alpha, i' : F_\alpha \dashrightarrow B_\alpha \rangle$ be the coend of the functor F_α as in Section 3.4.2 (it exists since $\text{Rep}(H)$ is modular and so finitely semisimple). Recall that, by Theorem 3.5, $A = \{A_\alpha\}_{\alpha \in \pi}$ and $B = \{B_\alpha\}_{\alpha \in \pi}$ are categorical Hopf π -algebras in $\text{Rep}_1(H)$. For any $\alpha \in \pi$, by the uniqueness of the coend, there exists a unique isomorphism $I_\alpha : A_\alpha \rightarrow B_\alpha$ such that $i'_M = I_\alpha \circ i_M$ for all module $M \in \text{Rep}_\alpha(H)$. Note that $I = \{I_\alpha\}_{\alpha \in \pi}$ is an isomorphism of categorical Hopf π -algebras. Indeed, for example, if M is a module in $\text{Rep}_\alpha(H)$, then

$$\Delta_\alpha^A \circ i_M = \Delta_M^A = (I_\alpha^{-1} \otimes I_\alpha^{-1}) \Delta_M^B = (I_\alpha^{-1} \otimes I_\alpha^{-1}) \circ \Delta_\alpha^B \circ i'_M = (I_\alpha^{-1} \otimes I_\alpha^{-1}) \circ \Delta_\alpha^B \circ I_\alpha \circ i_M,$$

and so by the uniqueness of the factorization through a coend, $\Delta_\alpha^B \circ I_\alpha = (I_\alpha \otimes I_\alpha) \circ \Delta_\alpha^A$.

Let us fix a non-zero right π -integral $\lambda = (\lambda_\alpha)_{\alpha \in \pi}$ for H . For any $\alpha \in \pi$, define $\mu_\alpha : \mathbb{k} \rightarrow A_\alpha$ by $\mu_\alpha(1) = \lambda_\alpha$. By Theorem 3.8, $\mu = (\mu_\alpha)_{\alpha \in \pi}$ is a right π -integral for the categorical Hopf π -algebra $A = \{A_\alpha\}_{\alpha \in \pi}$. Since $I = \{I_\alpha\}_{\alpha \in \pi}$ is an isomorphism of categorical Hopf π -algebra, $(I_\alpha \circ \mu_\alpha)_{\alpha \in \pi}$ is a right π -integral for the categorical Hopf π -algebra $B = \{B_\alpha\}_{\alpha \in \pi}$. Therefore, by Lemma 3.13, there

exists $k \in \mathbb{k}$ such that $I_\alpha \circ \mu_\alpha = k \mu_\alpha^{\text{semi}}$ for all $\alpha \in \pi$, where $\mu^{\text{semi}} = (\mu_\alpha^{\text{semi}})_{\alpha \in \pi}$ is as in (4.12). Note that k is non-zero since $\mu_\alpha(1) = \lambda_1$ is non-zero. Therefore, up to replacing λ with $k^{-1} \lambda$, we can (and we will) assume that $k = 1$. Hence, for any $\alpha \in \pi$,

$$(4.14) \quad \mu_\alpha^{\text{semi}} = I_\alpha \circ \mu_\alpha.$$

As in Section 4.3.2, let $T_{D_L^{\text{split}}} : B_{\alpha_1} \otimes \cdots \otimes B_{\alpha_n} \rightarrow \mathbb{1}$ be the (unique) morphism such that

$$F(D_L^{\text{split}}; M_1, \dots, M_n) = T_{D_L^{\text{split}}} \circ (i'_{M_1} \otimes \cdots \otimes i'_{M_n})$$

for all modules $M_1 \in \text{Rep}_{\alpha_1}(H), \dots, M_n \in \text{Rep}_{\alpha_n}(H)$. By Lemma 3.6, the morphism $h : A_{\alpha_1} \otimes \cdots \otimes A_{\alpha_n} \rightarrow \mathbb{k}$ which factorizes the function $(M_1, \dots, M_n) \mapsto F(D_L^{\text{split}}; M_1, \dots, M_n)$ through the coends $\langle A_\alpha, i : F_\alpha \rightrightarrows A_\alpha \rangle_{\alpha \in \pi}$ is given, for any $f_1 \in A_{\alpha_1} = H_{\alpha_1}^*, \dots, f_n \in A_{\alpha_n} = H_{\alpha_n}^*$, by

$$h(f_1 \otimes \cdots \otimes f_n) = \langle F(D_L^{\text{split}}; H_{\alpha_1}, \dots, H_{\alpha_n}), f_1 \otimes 1_{\alpha_1} \otimes \cdots \otimes f_n \otimes 1_{\alpha_n} \rangle.$$

Therefore, using Lemma 4.19, we have

$$\begin{aligned} h(f_1 \otimes \cdots \otimes f_n) &= \sum_l \text{ev}_{H_{\alpha_1}}(f_1 \otimes (a_l^1 \cdot 1_{\alpha_1})) \cdots \text{ev}_{H_{\alpha_n}}(f_n \otimes (a_l^n \cdot 1_{\alpha_n})) \\ &= \sum_l f_1(a_l^1) \cdots f_n(a_l^n) \\ &= \langle f_1 \otimes \cdots \otimes f_n, a_L^{\text{split}} \rangle. \end{aligned}$$

Now $h = T_{D_L^{\text{split}}} \circ (I_{\alpha_1} \otimes \cdots \otimes I_{\alpha_n})$ by the uniqueness of the factorization described in Corollary 3.3. Hence we obtain that, for any $f_1 \in H_{\alpha_1}^*, \dots, f_n \in H_{\alpha_n}^*$,

$$(4.15) \quad \langle T_{D_L^{\text{split}}} \circ (I_{\alpha_1} \otimes \cdots \otimes I_{\alpha_n}), f_1 \otimes \cdots \otimes f_n \rangle = \langle f_1 \otimes \cdots \otimes f_n, a_L^{\text{split}} \rangle.$$

This last formula allows us to compute $T_{D_L^{\text{split}}}$ from a_L^{split} .

LEMMA 4.20. $\lambda_1(\theta_1^{\pm 1}) = \Delta_\pm$.

Proof. Let us denote by δ_+ and δ_- the (oriented) diagrams of Figures 4.32(a) and 4.32(b).

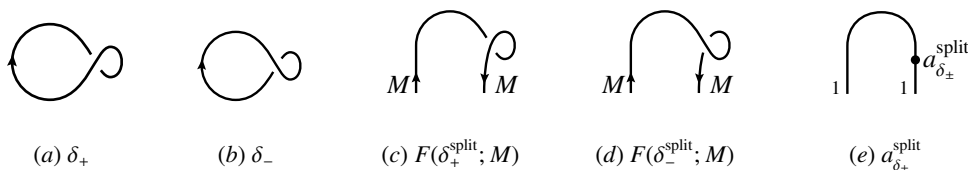

FIGURE 4.32.

Replacing D_L and D_L^{split} with δ_\pm and $\delta_\pm^{\text{split}}$ in the above setting leads to the oriented, $\text{Rep}(H)$ -colored $(2, 0)$ -tangle diagram $\delta_\pm^{\text{split}}$, see Figures 4.32(c) and 4.32(d) where $M \in \text{Rep}_1(H)$, to the morphism $T_{\delta_\pm^{\text{split}}} : B_1 \otimes B_1 \rightarrow \mathbb{k}$, and to the element $a_{\delta_\pm}^{\text{split}} \in H_1$, see Figure 4.32(e). Therefore, using the above computations, we have

$$\Delta_\pm = \sum_{j \in J_1} v_j^{\pm 1} \dim_q(V_j^1)^2$$

$$\begin{aligned}
&= \sum_{j \in J_1} F(\delta_{\pm}; V_j^1) \circ \widetilde{\text{coev}}_{V_j^1} \\
&= \sum_{j \in J_1} T_{\delta_{\pm}^{\text{split}}} \circ i'_{V_j^1} \circ \widetilde{\text{coev}}_{V_j^1} \\
&= T_{\delta_{\pm}^{\text{split}}} \circ \mu_1^{\text{semi}} \\
&= T_{\delta_{\pm}^{\text{split}}} \circ I_1 \circ \mu_1 \quad \text{by (4.14)} \\
&= \langle T_{\delta_{\pm}^{\text{split}}} \circ I_1, \mu_1(1) \rangle \\
&= \langle T_{\delta_{\pm}^{\text{split}}} \circ I_1, \lambda_1 \rangle \\
&= \langle \lambda_1, a_{\delta_{\pm}^{\text{split}}} \rangle \quad \text{by (4.15)} \\
&= \lambda_1(a_{\delta_{\pm}^{\text{split}}}).
\end{aligned}$$

Now, since $\varphi_1|_{H_1} = \text{id}_{H_1}$ and by using the computations of Figure 4.18, we obtain that $a_{\delta_{\pm}^{\text{split}}}^{\text{split}} = \theta_1^{\pm 1}$. Hence $\lambda_1(\theta_1^{\pm 1}) = \Delta_{\pm}$. \square

Since Δ_+ and Δ_- are invertible (because $\text{Rep}(H)$ is modular, see [47]) and $\lambda_1(\theta_1^{\pm 1}) = \Delta_{\pm}$ by Lemma 4.20, we have that $\lambda_1(\theta_1) \neq 0$ and $\lambda_1(\theta_1^{-1}) \neq 0$. Therefore the invariant τ_H defined in Section 4.2 is well-defined. Recall that

$$\begin{aligned}
\tau_H(M, \xi) &= \lambda_1(\theta_1)^{b_-(L)-n} \lambda_1(\theta_1^{-1})^{-b_-(L)} \sum_l \lambda_{\alpha_1}(a_l^1) \cdots \lambda_{\alpha_n}(a_l^n) \\
&= \lambda_1(\theta_1)^{b_-(L)-n} \lambda_1(\theta_1^{-1})^{-b_-(L)} \langle \lambda_{\alpha_1} \otimes \cdots \otimes \lambda_{\alpha_n}, a_L^{\text{split}} \rangle.
\end{aligned}$$

Finally, we have

$$\begin{aligned}
\mathcal{T}_{(\text{Rep}(H), D)}(M, \xi) &= \Delta_-^{\sigma(L)} D^{-\sigma(L)-n-1} T_{D_L^{\text{split}}} \circ (\mu_{\alpha_1}^{\text{semi}} \otimes \cdots \otimes \mu_{\alpha_n}^{\text{semi}}) \quad \text{by (4.13)} \\
&= \Delta_-^{\sigma(L)} D^{-\sigma(L)-n-1} T_{D_L^{\text{split}}} \circ (I_{\alpha_1} \circ \mu_{\alpha_1} \otimes \cdots \otimes I_{\alpha_n} \circ \mu_{\alpha_n}) \quad \text{by (4.14)} \\
&= \Delta_-^{\sigma(L)} D^{-\sigma(L)-n-1} T_{D_L^{\text{split}}} \circ (I_{\alpha_1} \otimes \cdots \otimes I_{\alpha_n}) \circ (\mu_{\alpha_1} \otimes \cdots \otimes \mu_{\alpha_n}) \\
&= \Delta_-^{\sigma(L)} D^{-\sigma(L)-n-1} \langle T_{D_L^{\text{split}}} \circ (I_{\alpha_1} \otimes \cdots \otimes I_{\alpha_n}), \mu_{\alpha_1}(1) \otimes \cdots \otimes \mu_{\alpha_n}(1) \rangle \\
&= \Delta_-^{\sigma(L)} D^{-\sigma(L)-n-1} \langle T_{D_L^{\text{split}}} \circ (I_{\alpha_1} \otimes \cdots \otimes I_{\alpha_n}), \lambda_{\alpha_1} \otimes \cdots \otimes \lambda_{\alpha_n} \rangle \\
&= \Delta_-^{\sigma(L)} D^{-\sigma(L)-n-1} \langle \lambda_{\alpha_1} \otimes \cdots \otimes \lambda_{\alpha_n}, a_L^{\text{split}} \rangle \quad \text{by (4.15)} \\
&= \Delta_-^{\sigma(L)} D^{-\sigma(L)-n-1} (\lambda_1(\theta_1)^{b_-(L)-n} \lambda_1(\theta_1^{-1})^{-b_-(L)})^{-1} \tau_H(M, \xi) \\
&= \Delta_-^{\sigma(L)+b_-(L)} D^{-\sigma(L)-n-1} \Delta_+^{n-b_-(L)} \tau_H(M, \xi) \quad \text{by Lemma 4.20} \\
&= \Delta_-^{\sigma(L)+b_-(L)} D^{-\sigma(L)-n-1} (D^2/\Delta_-)^{n-b_-(L)} \tau_H(M, \xi) \quad \text{by (4.11)} \\
&= D^{-1} \Delta_-^{\sigma(L)+2b_-(L)-n} D^{n-2b_-(L)-\sigma(L)} (D^2/\Delta_-)^n \tau_H(M, \xi).
\end{aligned}$$

Recall that $b_{\pm}(L)$ denotes the number of eigenvalues of sign \pm of the linking matrix of the framed link L and that the first Betti number $b_1(M)$ of the 3-manifold M is equal to the number of null eigenvalues of the linking matrix of L . We have that $n = b_+(L) + b_1(M) + b_-(L)$ and $\sigma(L) = b_+(L) - b_-(L)$. Therefore $\sigma(L) + 2b_-(L) - n = -b_1(M)$ and $n - 2b_-(L) - \sigma(L) = b_1(M)$. Hence

$$\mathcal{T}_{(\text{Rep}(H), D)}(M, \xi) = D^{-1} \left(\frac{D}{\Delta_-} \right)^{b_1(M)} \tau_H(M, \xi).$$

This completes the proof of Theorem 4.18.

4.4. Homotopy quantum field theory

The notion of a homotopy quantum field theory was introduced by Turaev [48]. Briefly recall that a homotopy quantum field theory in dimension $2 + 1$ with target a space X can be viewed as a topological quantum field theory for surfaces and cobordisms endowed with a homotopy class of maps to X . In this section, we show that the invariant τ_H constructed in Section 4.2 extends to a homotopy quantum field theory in dimension $2 + 1$ (between connected surfaces) with target the Eilenberg-Mac Lane space $K(\pi, 1)$.

4.4.1. Special π -tangles. Following [48], a π -tangle with $k \geq 0$ inputs and $l \geq 0$ outputs is a triple (T, z, g) where:

- $T \subset \mathbb{R}^2 \times [0, 1]$ is a framed tangle with bottom endpoints $(r, 0, 0)$, $r = 1, \dots, k$ and top endpoints $(s, 1, 0)$, $s = 1, \dots, l$. Recall that the tangle T consists of a finite number of pairwise disjoint embedded circles and arcs lying in the open strip $\mathbb{R}^2 \times]0, 1[$ except the endpoints of the arcs. At the endpoints, T should be orthogonal to the planes $\mathbb{R}^2 \times 0$ or $\mathbb{R}^2 \times 1$. Framed means that each component t of the tangle T is provided with a longitude $\tilde{t} \subset \mathbb{R}^2 \times [0, 1] \setminus T$ which goes very closely along t . We always assume that the longitudes of the arc components of T have endpoints $(r, -\delta, 0)$, $r = 1, \dots, k$ and $(s, -\delta, 0)$, $s = 1, \dots, l$ with small $\delta > 0$. We denote $\tilde{T} = \cup_t \tilde{t}$ where t runs over all the components of T ;
- the base point z belongs to $\mathbb{R}^2 \times [0, 1] \setminus T$ and has a big negative second coordinate z_2 so that $T \subset \mathbb{R} \times [z_2 + 1, +\infty[\times [0, 1]$;
- $g : \pi_1(\mathbb{R}^2 \times [0, 1] \setminus T, z) \rightarrow \pi$ is a group homomorphism.

Two π -links (T, z, g) and (T', z', g') are said to be *equivalent* if there is an orientation-preserving homeomorphism $h : \mathbb{R}^2 \times [0, 1] \rightarrow \mathbb{R}^2 \times [0, 1]$ such that $h(T) = T'$ (fixing the endpoints), $h(\tilde{T}) = \tilde{T}'$, $h(z) = z'$, and $g = g' \circ h_*$.

As for π -links, a π -tangle may be represented by a π -colored tangle diagram: regularly project the framed tangle T onto the plane $\mathbb{R} \times 0 \times \mathbb{R}$ so that the base point z corresponds to the eyes of the reader. Recall regularly means that the framing is given by shifting the tangle along the vector $(0, -\delta, 0)$ with small $\delta > 0$. As in Section 4.1.2, we color each vertical segment of the diagram by $g([\mu]) \in \pi$, where μ represents the loop that, starting from the base point z above the diagram, goes straight to the segment, encircles it from left to right and returns immediately to the base point (see Figure 4.3). Note that for crossings and extrema the colors are related as in Figure 4.1.

Reciprocally, using the Wirtinger presentation of tangle groups, one easily verifies that a π -colored tangle diagram determines (up to equivalence) a unique π -tangle.

The same arguments as in the proof of Lemma 4.1 shows that π -tangles are equivalent if and only if all their π -colored diagrams can be obtained one from the other by a finite sequence of isotopies (in the class of generic tangle diagrams) which preserve the inputs, the outputs, and the colors of the vertical segments and of moves of Figure 4.2.

Let (T, z, g) be a π -tangle with $k \geq 0$ inputs and $l \geq 0$ outputs. For $1 \leq i \leq k$, let α_i be the color of the vertical segment of a π -colored diagram of T corresponding to the i^{th} input. The element $\alpha_i \in \pi$ does not depend on the diagram representing T . It is called the *color* of the i^{th} input of T . Similarly, we define the *colors of outputs* of T .

We say that a π -tangle (T, z, g) is *special* if:

- it has an even number $2k \geq 0$ of inputs and, for $1 \leq i \leq k$, an arc joins the $(2i - 1)^{\text{th}}$ input to the $(2i)^{\text{th}}$ input;
- it has an even number $2l \geq 0$ of outputs and, for $1 \leq j \leq l$, an arc joins the $(2j - 1)^{\text{th}}$ output to the $(2j)^{\text{th}}$ output;

- there exists $\alpha_1, \beta_1, \dots, \alpha_k, \beta_k \in \pi$ such that $\prod_{i=1}^k [\alpha_i, \beta_i] = 1$ and, for any $1 \leq i \leq k$, α_i is the color of the $(2i-1)^{\text{th}}$ input and $\beta_i \alpha_i^{-1} \beta_i^{-1}$ is the color of the $(2i)^{\text{th}}$ input;
- there exists $\alpha'_1, \beta'_1, \dots, \alpha'_l, \beta'_l \in \pi$ such that $\prod_{j=1}^l [\alpha'_j, \beta'_j] = 1$ and, for any $1 \leq j \leq l$, α'_j is the color of the $(2j-1)^{\text{th}}$ output and $\beta'_j \alpha'^{-1}_j \beta'^{-1}_j$ is the color of the $(2j)^{\text{th}}$ output;
- for each circle component t of T , the longitude \tilde{t} is sent to $1 \in \pi$ by g .

The k -uple $(\alpha_1, \beta_1, \dots, \alpha_k, \beta_k)$ is called the *system of bottom colors* of the special π -tangle T and the l -uple $(\alpha'_1, \beta'_1, \dots, \alpha'_l, \beta'_l)$ is called the *system of top colors* of the special π -tangle T .

4.4.2. The spaces F_c and T_c . Fix a finite type crossed Hopf π -coalgebra $H = \{H_\alpha\}_{\alpha \in \pi}$ with crossing φ . Let $g \geq 1$ and $c = (\alpha_1, \beta_1, \dots, \alpha_g, \beta_g) \in \pi^{2g}$ with $\prod_{i=1}^g [\alpha_i, \beta_i] = 1$. We set

$$(4.16) \quad F_c = H_{\alpha_1}^* \otimes \dots \otimes H_{\alpha_g}^*.$$

It is a left H_1 -module under the action \triangleright defined by

$$\langle h \triangleright (f_1 \otimes \dots \otimes f_g), x_1 \otimes \dots \otimes x_g \rangle = \prod_{i=1}^g \langle f_i, S_{\alpha_i}^{-1}(\varphi_{\beta_i^{-1}}(h_{(2i, \beta_i \alpha_i^{-1} \beta_i^{-1})})) x_i h_{(2i-1, \alpha_i)} \rangle,$$

where \langle, \rangle denotes the usual pairing between a \mathbb{k} -space and its dual. We also define the \mathbb{k} -space

$$(4.17) \quad T_c = \{X \in H_{\alpha_1} \otimes \dots \otimes H_{\alpha_g} \mid X \triangleleft h = \varepsilon(h)X \text{ for all } h \in H_1\},$$

where \triangleleft is the right action of H_1 on $H_{\alpha_1} \otimes \dots \otimes H_{\alpha_g}$ given by

$$(x_1 \otimes \dots \otimes x_g) \triangleleft h = \bigotimes_{i=1}^g S_{\alpha_i}^{-1}(\varphi_{\beta_i^{-1}}(h_{(2i, \beta_i \alpha_i^{-1} \beta_i^{-1})})) x_i h_{(2i-1, \alpha_i)}.$$

Note that, for any $f_1 \in H_{\alpha_1}^*, \dots, f_g \in H_{\alpha_g}^*$ and $x_1 \in H_{\alpha_1}, \dots, x_g \in H_{\alpha_g}$, we have

$$\langle h \triangleright (f_1 \otimes \dots \otimes f_g), x_1 \otimes \dots \otimes x_g \rangle = \langle f_1 \otimes \dots \otimes f_g, (x_1 \otimes \dots \otimes x_g) \triangleleft h \rangle.$$

We set $F_\emptyset = \mathbb{k}$, endowed with the usual left H_1 -action given by $h \triangleright k = \varepsilon(h)k$, and $T_\emptyset = \mathbb{k}$.

For example, when $\alpha, \beta \in \pi$ with $\alpha\beta = \beta\alpha$, we have that

$$T_{(\alpha, \beta)} = \{x \in H_\alpha \mid yx = x\varphi_\beta(y) \text{ for all } y \in H_\alpha\}.$$

Indeed, for any $x \in T_{(\alpha, \beta)}$ and $y \in H_\alpha$,

$$\begin{aligned} yx &= y_{(2, \alpha)} \varepsilon(y_{(1, 1)}) x && \text{by (1.2)} \\ &= y_{(2, \alpha)} \varepsilon(\varphi_\beta(y_{(1, 1)})) x && \text{by (2.3)} \\ &= y_{(2, \alpha)} S_\alpha^{-1}(\varphi_{\beta^{-1}}(\varphi_\beta(y_{(1, 1)}))_{(2, \beta \alpha^{-1} \beta^{-1})}) x \varphi_\beta(y_{(1, 1)})_{(1, \alpha)} && \text{since } x \in T_{(\alpha, \beta)} \\ &= y_{(3, \alpha)} S_\alpha^{-1}(y_{(2, \alpha^{-1})}) x \varphi_\beta(y_{(1, \alpha)}) && \text{by (2.2)} \\ &= x \varphi_\beta(\varepsilon(y_{(2, 1)})) y_{(1, \alpha)} && \text{by (1.5)} \\ &= x \varphi_\beta(y). \end{aligned}$$

Conversely, if $x \in H_\alpha$ is such that $yx = x\varphi_\beta(y)$ for all $y \in H_\alpha$, then, for any $h \in H_1$,

$$\begin{aligned} S_\alpha^{-1}(\varphi_{\beta^{-1}}(h_{(2, \beta \alpha^{-1} \beta^{-1})})) x h_{(1, \alpha)} &= \varphi_{\beta^{-1}}(S_\alpha^{-1}(h_{(2, \alpha^{-1})})) x h_{(1, \alpha)} && \text{by Lemma 2.1(c)} \\ &= x S_\alpha^{-1}(h_{(2, \alpha^{-1})}) h_{(1, \alpha)} \\ &= \varepsilon(h)x && \text{by (1.5)}. \end{aligned}$$

Furthermore, if $\varphi_\beta|_{H_\alpha} = \text{id}_{H_\alpha}$, then $T_{(\alpha, \beta)} = Z(H_\alpha)$. In particular $T_{(\alpha, 1)} = Z(H_\alpha)$ for all $\alpha \in \pi$.

LEMMA 4.21. *The map $\delta_c : T_c \rightarrow \text{Hom}_{H_1}(F_c, \mathbb{k})$, defined by*

$$\delta_c(x_1 \otimes \cdots \otimes x_g)(f_1 \otimes \cdots \otimes f_g) = f_1(x_1) \cdots f_g(x_g),$$

is an isomorphism of \mathbb{k} -spaces.

Proof. Let us first prove that δ_c is well-defined. Let $X \in T_c$. For all $f_1 \in H_{\alpha_1}^*, \dots, f_g \in H_{\alpha_g}^*$, and $h \in H_1$, we have

$$\begin{aligned} \delta_c(X)(h \triangleright (f_1 \otimes \cdots \otimes f_g)) &= \langle h \triangleright (f_1 \otimes \cdots \otimes f_g), X \rangle \\ &= \langle f_1 \otimes \cdots \otimes f_g, X \triangleleft h \rangle \\ &= \varepsilon(h) \langle f_1 \otimes \cdots \otimes f_g, X \rangle \quad \text{since } X \in T_c \\ &= \varepsilon(h) \delta_c(X)(f_1 \otimes \cdots \otimes f_g). \end{aligned}$$

Therefore the map $\delta_c(X)$ is H_1 -linear. Moreover it is clear that δ_c is \mathbb{k} -linear. It remains to verify that δ_c is bijective. Let $f \in \text{Hom}_{H_1}(F_c, \mathbb{k})$. Let us show that f has a unique antecedent by δ_c . Via the canonical \mathbb{k} -isomorphism $F_c^* = (H_{\alpha_1}^* \otimes \cdots \otimes H_{\alpha_g}^*)^* \cong H_{\alpha_1} \otimes \cdots \otimes H_{\alpha_g}$ (it is an isomorphism since H is of finite type), there exists a unique $X \in H_{\alpha_1} \otimes \cdots \otimes H_{\alpha_g}$ such that $f = \text{ev}_X$, where ev_X denotes the standard evaluation on X . Since $f : F_c \rightarrow \mathbb{k}$ is H_1 -linear, we have that $X \in T_c$. Hence $f = \delta_c(X)$. \square

4.4.3. Maps associated to special π -tangles. Fix a finite unimodular ribbon Hopf π -coalgebra $H = \{H_\alpha\}_{\alpha \in \pi}$ and a right π -integral $\lambda = (\lambda_\alpha)_{\alpha \in \pi}$ for H . We assume that $\lambda_1(\theta_1) \neq 0$ and $\lambda_1(\theta_1^{-1}) \neq 0$, where $\theta = \{\theta_\alpha\}_{\alpha \in \pi}$ denotes the twist of H . Recall that, by Theorem 2.14, the family $(x \in H_\alpha \mapsto \lambda_\alpha(G_\alpha x) \in \mathbb{k})_{\alpha \in \pi}$ is a π -trace for H , where $G = (G_\alpha)_{\alpha \in \pi}$ is the spherical π -grouplike element of H .

Let (T, z, g) be a special π -link with $2k$ inputs and $2l$ outputs. Denote by $c = (\alpha_1, \beta_1, \dots, \alpha_k, \beta_k)$ its system of bottom colors and by $c' = (\alpha'_1, \beta'_1, \dots, \alpha'_l, \beta'_l)$ its system of top colors. Note that $c = \emptyset$ (resp. $c' = \emptyset$) if T has no inputs (resp. no outputs). Let n be the number of circle components of T .

Present the π -tangle (T, z, g) by a π -colored tangle diagram D . Each crossing of the π -colored tangle diagram D is decorated with the R -matrix as explained in Step (B) of Section 4.1.4. The diagram obtained after this step is called the *flat diagram of T* . By applying the rules of Figures 4.5, 4.6, and 4.7, we transform the flat diagram of T so that it has the form depicted in Figure 4.33, where $a_u^i \in H_{\alpha_i}$, $b_v^j \in H_{\alpha_j^{-1}}$, and $c_w^m \in H_{\gamma_m}$.

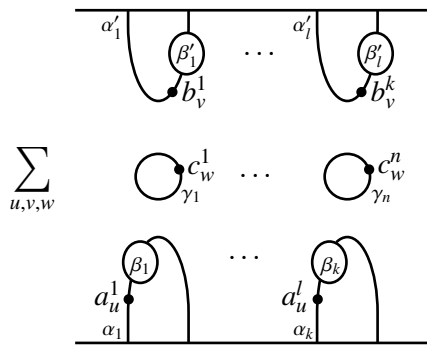

FIGURE 4.33.

Finally, we define the \mathbb{k} -linear map $\psi_H(T, z, g) : T_{c'} \rightarrow T_c$, where the \mathbb{k} -spaces $T_{c'}$ and T_c are as in (4.17), by setting, for any $X = \sum_i x_i^1 \otimes \cdots \otimes x_i^n \in T_{c'}$,

$$\psi_H(T, z, g)(X) = \sum_{u,v,w,i} \lambda_{\gamma_1}(c_w^1) \cdots \lambda_{\gamma_n}(c_w^n) \lambda_{\alpha_1^{-1}}(S_{\alpha_1}(x_1^i) b_v^1) \cdots \lambda_{\alpha_l^{-1}}(S_{\alpha_l}(x_l^i) b_v^l) a_u^1 \otimes \cdots \otimes a_u^k.$$

LEMMA 4.22. *The map $\psi_H(T, z, g)$ is well-defined and only depends on the equivalence class of the special π -tangle (T, z, g) .*

Proof. Let D be a π -colored diagram of the special π -tangle (T, z, g) . We temporarily denote $\psi_H(T, z, g)$ by $\psi(D)$. We have to show that $\psi(D)$ is well-defined and remains unchanged if a move of Figure 4.2 is applied to D .

Let F_c and $F_{c'}$ be the left H_1 -modules defined as in (4.16). Recall that $F_c = H_{\alpha_1}^* \otimes \cdots \otimes H_{\alpha_k}^*$ and $F_{c'} = H_{\alpha_1'}^* \otimes \cdots \otimes H_{\alpha_l'}^*$ as \mathbb{k} -spaces. Denote by D_f the flat diagram of T arising from D . We define a \mathbb{k} -linear map $\phi(D_f) : F_c \rightarrow F_{c'}$ by setting

$$\begin{aligned} & \langle \phi(D_f)(f_1 \otimes \cdots \otimes f_k), x_1 \otimes \cdots \otimes x_l \rangle \\ &= \sum_{u,v,w} \lambda_{\gamma_1}(c_w^1) \cdots \lambda_{\gamma_n}(c_w^n) \lambda_{\alpha_1'}(S_{\alpha_1'}(x_1) b_v^1) \cdots \lambda_{\alpha_l'}(S_{\alpha_l'}(x_l) b_v^l) f_1(a_u^1) \cdots f_k(a_u^k). \end{aligned}$$

for any $f_1 \in H_{\alpha_1}^*, \dots, f_k \in H_{\alpha_k}^*$ and $x_1 \in H_{\alpha_1'}, \dots, x_l \in H_{\alpha_l}'$.

The map $\phi(D_f)$ does not depend on the manner of transforming the flat diagram D_f so that it looks like as in Figure 4.33. Indeed, the element a_u^i (resp. b_v^j) is unique (since it is the result of the concentration of the algebraic decoration and the cancellation of the curls of an arc) and the scalar $\lambda_{\gamma_k}(c_w^k)$ does not depend on the way of concentrating the algebraic decoration and cancelling the curls (see the proof of Theorem 4.3). Therefore the map $\phi(D_f)$ is well-defined.

Let us show that it is H_1 -linear. Let $h \in H_1$. Denote by $\Delta_c(h)$ the flat diagram with $2k$ inputs and $2k$ outputs of Figure 4.34. We define analogously the flat diagram $\Delta_{c'}(h)$ with $2l$ inputs and $2l$ outputs.



FIGURE 4.34. The flat diagram $\Delta_c(h)$

Let us show that

$$(4.18) \quad D_f \Delta_c(h) \equiv \Delta_{c'}(h) D_f,$$

where “ \equiv ” means that these flat diagrams are related by a finite sequence of moves of Figure 4.5. Let us recall that the algebraic decoration of D_f comes from:



where $\alpha, \beta \in \pi$, $R_{\alpha, \beta} = a_\alpha \otimes b_\beta$, and $R_{\beta^{-1}, \alpha} = c_{\beta^{-1}} \otimes d_\alpha$. Firstly, for any $h \in H_{\alpha\beta}$, since

$$\begin{aligned} a_\alpha h_{(1, \alpha)} \otimes b_\beta h_{(2, \beta)} &= R_{\alpha, \beta} \Delta_{\alpha, \beta}(h) \\ &= \sigma_{\beta, \alpha}(\varphi_{\alpha^{-1}} \otimes \text{id}_{H_\alpha}) \Delta_{\alpha\beta\alpha^{-1}, \alpha}(h) \cdot R_{\alpha, \beta} \quad \text{by (2.5)} \\ &= h_{(2, \alpha)} a_\alpha \otimes \varphi_{\alpha^{-1}}(h_{(1, \alpha\beta\alpha^{-1})}) b_\beta, \end{aligned}$$

we have that:

Secondly, for any $h \in H_{\alpha\beta}$, since

$$\begin{aligned}
& h_{(1,\beta)} S_{\beta^{-1}}(c_{\beta^{-1}}) \otimes \varphi_{\beta}(h_{(2,\beta^{-1}\alpha\beta)}) d_{\alpha} \\
&= (\text{id}_{H_{\beta}} \otimes \varphi_{\beta}) \Delta_{\beta, \beta^{-1}\alpha\beta}(h) \cdot (S_{\beta^{-1}} \otimes \text{id}_{H_{\alpha}})(R_{\beta^{-1}, \alpha}) \\
&= (\text{id}_{H_{\beta}} \otimes \varphi_{\beta}) \Delta_{\beta, \beta^{-1}\alpha\beta}(h) \cdot (\varphi_{\beta^{-1}} \otimes \text{id}_{H_{\alpha}})(R_{\beta, \alpha}^{-1}) \quad \text{by Lemma 2.4(b)} \\
&= (\text{id}_{H_{\beta}} \otimes \varphi_{\beta})(\Delta_{\beta, \beta^{-1}\alpha\beta}(h) \cdot R_{\beta, \beta^{-1}\alpha\beta}^{-1}) \quad \text{by (2.7)} \\
&= (\text{id}_{H_{\beta}} \otimes \varphi_{\beta})(R_{\beta, \beta^{-1}\alpha\beta}^{-1} \cdot \sigma_{\beta^{-1}\alpha\beta, \beta}(\varphi_{\beta^{-1}} \otimes \text{id}_{H_{\beta}}) \Delta_{\alpha, \beta}(h)) \quad \text{by (2.5)} \\
&= (\text{id}_{H_{\beta}} \otimes \varphi_{\beta})(R_{\beta, \beta^{-1}\alpha\beta}^{-1} \cdot \sigma_{\alpha, \beta} \Delta_{\alpha, \beta}(h)) \\
&= (\varphi_{\beta^{-1}} \otimes \text{id}_{H_{\alpha}})(R_{\beta, \alpha}^{-1}) \cdot \sigma_{\alpha, \beta} \Delta_{\alpha, \beta}(h) \quad \text{by (2.7)} \\
&= (S_{\beta^{-1}} \otimes \text{id}_{H_{\alpha}})(R_{\beta^{-1}, \alpha}) \cdot \sigma_{\alpha, \beta} \Delta_{\alpha, \beta}(h) \quad \text{by Lemma 2.4(b)} \\
&= S_{\beta^{-1}}(c_{\beta^{-1}}) h_{(2,\beta)} \otimes d_{\alpha} h_{(1,\alpha)},
\end{aligned}$$

we have that:

Finally, for any $h \in H_1$, by using (1.5), we have:

and

By decomposing the flat diagram D_f into (algebraized) crossings, cup-likes, and cap-likes and by using (1.1), (1.2), and the above four equalities, we obtain that $D_f \Delta_c(h) \equiv \Delta_{c'}(h) D_f$. Hence (4.18) is proven.

Let us remark that, by using the rules of Figure 4.5, we have the equalities of Figures 4.35(a) and 4.35(b). Then, by using these equalities and (4.18), we get that, for all $f_1 \in H_{\alpha_1}^*, \dots, f_k \in H_{\alpha_k}^*$ and $x_1 \in H_{\alpha'_1}, \dots, x_l \in H_{\alpha'_l}$,

$$\begin{aligned}
& \langle \phi(D_f)(h \triangleright (f_1 \otimes \dots \otimes f_k)), x_1 \otimes \dots \otimes x_l \rangle \\
&= \sum_{u,v,w} \prod_{m=1}^n \lambda_{\gamma_m}(c_w^m) \prod_{j=1}^l \lambda_{\alpha'_j} \langle S_{\alpha'_j}(x_j) b_j^j \rangle \prod_{i=1}^k f_i(S_{\alpha_i}^{-1}(\varphi_{\beta_i}^{-1}(h_{(2i, \beta_i \alpha_i^{-1} \beta_i^{-1})})) a_u^i h_{(2i-1, \alpha_i)}) \\
&= \langle \phi(D_f \Delta_c(h))(f_1 \otimes \dots \otimes f_k), x_1 \otimes \dots \otimes x_l \rangle \\
&= \langle \phi(\Delta_{c'}(h) D_f)(f_1 \otimes \dots \otimes f_k), x_1 \otimes \dots \otimes x_l \rangle
\end{aligned}$$

$$\begin{aligned}
& S_{\alpha_i}^{-1}(\varphi_{\beta_i^{-1}}(h_{(2i, \beta_i \alpha_i^{-1} \beta_i^{-1})})) a_u^i h_{(2i-1, \alpha_i)} \\
& \quad \equiv \quad h_{(2i-1, \alpha_i)} a_u^i h_{(2i, \beta_i \alpha_i^{-1} \beta_i^{-1})}
\end{aligned}
\tag{a}$$

$$\begin{aligned}
& h_{(2j-1, \alpha'_j)} h_{(2j, \beta'_j \alpha'_j \beta'_j^{-1})} \\
& \quad \equiv \quad h_{(2j, \beta'_j \alpha'_j \beta'_j^{-1})} b_v^j S_{\alpha'_j}^{-1}(h_{(2j-1, \alpha'_j)})
\end{aligned}
\tag{b}$$

FIGURE 4.35.

$$= \sum_{u,v,w} \prod_{m=1}^n \lambda_{\gamma_m}(c_w^m) \prod_{i=1}^k f_i(a_u^i) \prod_{j=1}^l \lambda_{\alpha'_j}^{-1}(S_{\alpha'_j}(x_j) \varphi_{\beta'_j}^{-1}(h_{(2j, \beta'_j \alpha'_j \beta'_j^{-1})})) b_v^j S_{\alpha'_j}^{-1}(h_{(2j-1, \alpha'_j)}).$$

Now, for any $1 \leq j \leq l$,

$$\begin{aligned}
& \lambda_{\alpha'_j}^{-1}(S_{\alpha'_j}(x_j) \varphi_{\beta'_j}^{-1}(h_{(2j, \beta'_j \alpha'_j \beta'_j^{-1})})) b_v^j S_{\alpha'_j}^{-1}(h_{(2j-1, \alpha'_j)}) \\
& = \lambda_{\alpha'_j}^{-1}(S_{\alpha'_j}(h_{(2j-1, \alpha'_j)}) S_{\alpha'_j}(x_j) \varphi_{\beta'_j}^{-1}(h_{(2j, \beta'_j \alpha'_j \beta'_j^{-1})})) b_v^j \quad \text{by Theorem 1.16(a)} \\
& = \lambda_{\alpha'_j}^{-1}(S_{\alpha'_j}(S_{\alpha'_j}^{-1}(\varphi_{\beta'_j}^{-1}(h_{(2j, \beta'_j \alpha'_j \beta'_j^{-1})}))) x_j h_{(2j-1, \alpha'_j)}) b_v^j \quad \text{by Lemma 1.1.}
\end{aligned}$$

Therefore

$$\begin{aligned}
& \langle \phi(D_f)(h \triangleright (f_1 \otimes \cdots \otimes f_k)), x_1 \otimes \cdots \otimes x_l \rangle \\
& = \sum_{u,v,w} \prod_{m=1}^n \lambda_{\gamma_m}(c_w^m) \prod_{i=1}^k f_i(a_u^i) \prod_{j=1}^l \lambda_{\alpha'_j}^{-1}(S_{\alpha'_j}(S_{\alpha'_j}^{-1}(\varphi_{\beta'_j}^{-1}(h_{(2j, \beta'_j \alpha'_j \beta'_j^{-1})}))) x_j h_{(2j-1, \alpha'_j)}) b_v^j \\
& = \langle h \triangleright \phi(D_f)(f_1 \otimes \cdots \otimes f_k), x_1 \otimes \cdots \otimes x_l \rangle.
\end{aligned}$$

Hence $\phi(D_f) : F_c \rightarrow F_{c'}$ is H_1 -linear.

We denote by ${}^t\phi(D_f)$ the map from $\text{Hom}_{H_1}(F_{c'}, \mathbb{k})$ to $\text{Hom}_{H_1}(F_c, \mathbb{k})$ defined by ${}^t\phi(D_f)(g) = g \circ \phi(D_f)$. It is well-defined since $\phi(D)$ is H_1 -linear. Let $\delta_c : T_c \rightarrow \text{Hom}_{H_1}(F_c, \mathbb{k})$ and $\delta_{c'} : T_{c'} \rightarrow \text{Hom}_{H_1}(F_{c'}, \mathbb{k})$ be as in Section 4.4.2. Then, for all $X = \sum_j x_1^j \otimes \cdots \otimes x_l^j \in T_{c'}$, we have

$$\begin{aligned}
& \delta_c^{-1} \circ {}^t\phi(D_f) \circ \delta_{c'}(X) \\
& = \delta_c^{-1}(\delta_{c'}(X) \circ \phi(D_f)) \\
& = \sum_{u,v,w,j} \lambda_{\gamma_1}(c_w^1) \cdots \lambda_{\gamma_n}(c_w^n) \lambda_{\alpha'_1}^{-1}(S_{\alpha'_1}(x_1^j) b_v^1) \cdots \lambda_{\alpha'_l}^{-1}(S_{\alpha'_l}(x_l^j) b_v^l) a_u^1 \otimes \cdots \otimes a_u^k \\
& = \psi(D_f)(X).
\end{aligned}$$

Therefore we can conclude that $\psi(D) = \delta_c^{-1} \circ \iota \phi(D_f) \circ \delta_{c'} : T_{c'} \rightarrow T_c$. Hence $\psi(D)$ is a well-defined \mathbb{k} -linear map.

By the same arguments as in the proof of Theorem 4.3 (using the π -trace $(\lambda_\alpha(G_{\alpha'})_{\alpha \in \pi})$, we obtain that the map $\psi(D)$ remains unchanged if a move of Figure 4.2 is applied to D . Hence the map $\psi_H(T, z, g)$ is well-defined and only depends on the equivalent class of the special π -tangle (T, z, g) . \square

Two special π -tangles (T', z', g') and (T, z, g) are said to be *composable* if the number of inputs of T' equals the number of outputs of T and the system of bottom colors of T' equals the system of upper colors of T .

Let (T', z', g') and (T, z, g) be two composable special π -tangles and D' and D be π -colored diagrams for T' and T respectively. Since the system of upper colors of T equals the system of bottom colors of T' , we have that the tangle diagram $D'D$ (obtained by placing D' on the top of D and by gluing the corresponding free ends) is π -colored and so represents a unique (up to equivalence) special π -tangle, denoted $(T', z', g') \circ (T, z, g)$ and called *composition* of (T', z', g') with (T, z, g) , whose underlying tangle is $T'T$.

LEMMA 4.23. *If (T', z', g') and (T, z, g) are two composable special π -tangles, then*

$$\psi_H((T', z', g') \circ (T, z, g)) = \psi_H(T, z, g) \circ \psi_H(T', z', g').$$

Proof. It follows directly from the equality depicted in Figure 4.36 obtained by using the rules of Figures 4.5 and 4.7, where $\alpha, \beta \in \pi$, $a \in H_\alpha$ and $b \in H_{\alpha^{-1}}$. \square

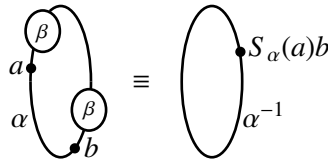

FIGURE 4.36.

4.4.4. π -surfaces. Let $g \geq 0$. We define $R_g \subset \mathbb{R} \times 0 \times]0, 1[\subset \mathbb{R}^3 \subset S^3$ to be a rectangle with g cap-like arcs attached on his to base, as depicted in Figure 4.37(a). We fix a point q_g inside the

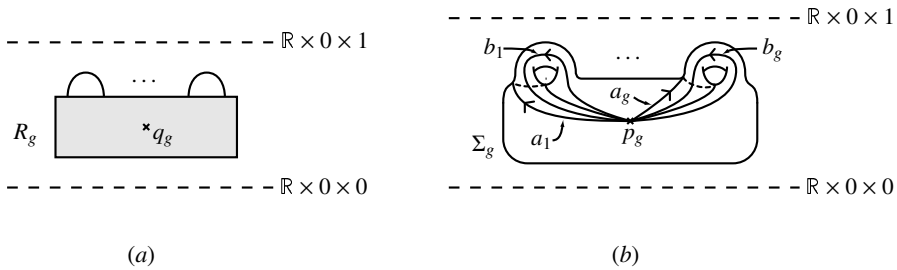

FIGURE 4.37.

rectangle of R_g . Let U_g be a compact and connected regular neighborhood of R_g . We assume that $U_g \subset \mathbb{R} \times \mathbb{R} \times]0, 1[$. Clearly, U_g is a handlebody of genus g . We provide U_g with the right-handed

orientation. Set $\Sigma_g = \partial U_g$. It is a closed and connected surface of genus g which we oriented with the orientation induced by that of U_g . Define the point $p_g \in \Sigma_g$ to be the intersection of Σ_g with $q_g + \mathbb{R}_+(0, -1, 0)$. Let $a_1, \dots, a_g, b_1, \dots, b_g$ be the loops on (Σ_g, p_g) defined as in Figure 4.37(b). Note that

$$(4.19) \quad \pi_1(\Sigma_g, p_g) = \langle [a_i], [b_i] \mid \prod_{i=1}^g [a_i][b_i][a_i]^{-1}[b_i]^{-1} \rangle.$$

We also define R'_g, U'_g , and Σ'_g to be the image of R_g, U_g , and Σ_g respectively under the symmetry $\text{Sym} : \mathbb{R}^3 \rightarrow \mathbb{R}^3$ with respect to the plane $\mathbb{R}^2 \times \frac{1}{2}$, see Figure 4.38.

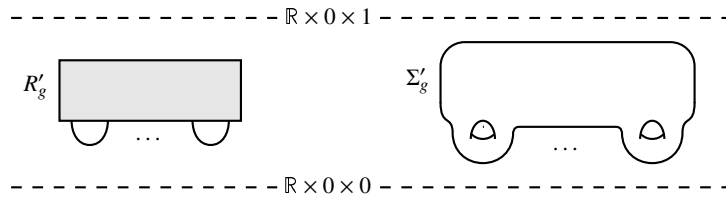

FIGURE 4.38.

We will assume that the arcs attached to the rectangles of R_g and R'_g are endowed with the blackboard framing of Figures 4.37(a) and 4.38.

The pointed surface (Σ_g, p_g) is called the *standard pointed surface of genus g* .

A pointed surface (Σ, p) is said to be *parameterized* if it is endowed with an orientation-preserving homeomorphism $\phi : (\Sigma_g, p_g) \rightarrow (\Sigma, p)$, where g is the genus of Σ .

By a π -*surface*, we shall mean a pointed, closed, connected, and oriented surface (Σ, p) endowed with a homomorphism $g : \pi_1(\Sigma, p) \rightarrow \pi$. A π -surface (Σ, p, g) is said to be *parameterized* if the pointed surface (Σ, p) is parameterized.

Two parameterized π -surfaces (Σ, p, g, ϕ) and (Σ', p', g', ϕ') are said to be *equivalent* if there exists an orientation-preserving homeomorphism $h : \Sigma \rightarrow \Sigma'$ such that $h \circ \phi = \phi'$ (note that this implies $h(p) = p'$) and $g' \circ h_* = g$, where $h_* : \pi_1(\Sigma, p) \rightarrow \pi_1(\Sigma', p')$ is the induced homomorphism.

Let (Σ, p, g, ϕ) be a parameterized π -surface of genus g . For any $1 \leq i \leq g$, set

$$(4.20) \quad \alpha_i = g([\phi \circ a_i]) \in \pi \quad \text{and} \quad \beta_i = g([\phi \circ b_i]) \in \pi,$$

where the a_i, b_i are the loops on the standard surface Σ_g which are defined as in Figure 4.37(b). The sequence $c = (\alpha_1, \beta_1, \dots, \alpha_g, \beta_g)$ is called the *system of colors* of the parameterized π -surface (Σ, p, g, ϕ) . Note that $c = \emptyset$ if the genus of the surface Σ is zero.

Remark that the system of colors of (Σ, p, g, ϕ) remains unchanged under equivalence of parameterized π -surfaces. Moreover, a family $c = (\alpha_1, \beta_1, \dots, \alpha_g, \beta_g)$, possibly void, of elements of π verifying $\prod_{i=1}^g [\alpha_i, \beta_i] = 1$ leads to a unique morphism $g_c : \pi_1(\Sigma_g, p_g) \rightarrow \pi$ (given by $g_c([a_i]) = \alpha_i$ and $g_c([b_i]) = \beta_i$ for any $1 \leq i \leq g$) and so determines a parameterized π -surface $(\Sigma_g, p_g, g_c, \text{id}_{\Sigma_g})$. Hence, the equivalence class of a parameterized π -surface is entirely determined by its system of colors.

4.4.5. π -cobordisms. Until the end of this section, we fix an Eilenberg-Mac Lane space $X = K(\pi, 1)$ with base point $x \in X$. We assume that X is a CW-space.

By a *3-cobordism*, we shall mean a compact, connected, and oriented 3-manifold M whose boundary has a decomposition $\partial M = (-\partial_- M) \amalg \partial_+ M$, where $\partial_- M$ and $\partial_+ M$ are pointed, closed, connected, oriented, and parameterized surfaces.

A π -cobordism is a couple (M, f) consisting in a 3-cobordism M and a (continuous) map $f : M \rightarrow X$, sending the base points of ∂M to $x \in X$, considered up to homotopy relative to ∂M .

Remark that the surfaces $\partial_{\pm}M$, endowed with $f_* \circ (i_{\partial_{\pm}M})_* : \pi_1(\partial_{\pm}M, x_{\pm}) \rightarrow \pi_1(X, x) = \pi$, where x_{\pm} is the base point of $\partial_{\pm}M$, are parameterized π -surfaces.

A π -cobordism with empty boundary is a π -manifold in the sense of Section 4.2. Indeed, for any path connected CW-space Y , the set of free homotopy classes of maps from Y to X is in one-to-one correspondence with the set of conjugacy classes of homomorphisms $\pi_1(Y) \rightarrow \pi_1(X, x) = \pi$ (by [44, THEOREM 8.11]) and so with the set of isomorphic principal π -bundle over Y (since π is discrete).

Two π -cobordisms (M, f) and (M', f') are said to be *equivalent* if there exists an orientation-preserving homeomorphism $h : M \rightarrow M'$ such that $h(\partial_{\pm}M) = \partial_{\pm}M'$, $\phi_{\partial_{\pm}M} = h \circ \phi_{\partial_{\pm}M'}$ (where $\phi_{\partial_{\pm}M}$ is the parameterizations of the surface $\partial_{\pm}M$), and $f' \circ h$ is homotopic to f relative to ∂M .

Note that it implies that the parameterized π -surfaces $\partial_{\pm}M'$ and $\partial_{\pm}M$ are equivalent.

4.4.6. Presentation of π -cobordisms by special π -tangles. A special π -tangle may be associated to a π -cobordism (M, f) by the following procedure: let k (resp. l) be the genus of ∂_-M (resp. ∂_+M) and denote by $\phi_- : (\Sigma_k, p_k) \rightarrow (\partial_-M, x_-)$ (resp. $\phi_+ : (\Sigma_l, p_l) \rightarrow (\partial_+M, x_+)$) the parameterization of ∂_-M (resp. ∂_+M). Glue the handlebodies U_k and U'_l to M along $\phi_- : \Sigma_k = \partial U_k \rightarrow \partial_-M$ and $\phi_+ \circ \text{Sym} : \Sigma'_l \rightarrow \partial_+M$ respectively (see Section 4.4.4). The result of these gluings is a closed, connected, and oriented 3-manifold \overline{M} . Present this manifold \overline{M} by surgery on S^3 along a framed link L : there exists an orientation-preserving homeomorphism $h : \overline{M} \rightarrow S^3_L$. By applying some isotopy to L so that the handlebodies $h(U_k)$ and $h(U'_l)$ lie into $S^3 \setminus L$, we can assume that

- L lie in the strip $\mathbb{R}^2 \times]0, 1[\subset S^3$ and avoid the handlebodies $h(U_k)$ and $h(U'_l)$;
- the top base of rectangle of $h(R_k)$ lies in $\mathbb{R} \times 0 \times 0$, the k cup-like arcs of $h(R_k)$ lie in the strip $\mathbb{R}^2 \times]0, 1[$ except their endpoints, and these endpoints are $(r, 0, 0)$, $r = 1 \dots 2k$;
- the bottom base of rectangle of $h(R'_l)$ lies in $\mathbb{R} \times 0 \times 1$, the l cup-like arcs of $h(R'_l)$ lie in the strip $\mathbb{R}^2 \times]0, 1[$ except their endpoints, and these endpoints are $(s, 0, 1)$, $s = 1 \dots 2l$.

Cutting out both rectangles of $h(R_k)$ and $h(R'_l)$, we get a tangle T with $2k$ inputs and $2l$ outputs. Choose a point $z \in \mathbb{R}^2 \times [0, 1] \setminus T$ (with sufficiently big negative second coordinate). Up to homotopy f relative to ∂M , we can assume that z is sent to $x \in X$ under the map

$$\mathbb{R}^2 \times [0, 1] \setminus T \hookrightarrow S^3_L \setminus h(U_k) \cup h(U'_l) \xrightarrow{h^{-1}} M \xrightarrow{f} X.$$

Denote by $g : \pi_1(\mathbb{R}^2 \times [0, 1] \setminus T, z) \rightarrow \pi_1(X, x) = \pi$ the homomorphism induced by this map. Then (T, z, g) is a π -tangle with $2k$ inputs and $2k$ outputs. By definition of the surgery along a framed link, the longitude \tilde{t} of any circle component t of T is contractible and so are sent to $1 \in \pi$ by g . Set $\alpha_i = g([h \circ \phi_- \circ a_i])$ and $\beta_i = g([h \circ \phi_- \circ b_i])$ for $1 \leq i \leq k$. Then, using (4.19), we have

$$\prod_{i=1}^k [\alpha_i, \beta_i] = f_* \left(\prod_{i=1}^k [a_i][b_i][a_i]^{-1}[b_i]^{-1} \right) = f_*(1) = 1 \in \pi$$

Moreover, by construction, for any $1 \leq i \leq k$, α_i is the color of the $(2i - 1)^{\text{th}}$ input of T and $\beta_i \alpha_i^{-1} \beta_i^{-1}$ is the color of the $(2i)^{\text{th}}$ input of T . Set $\alpha'_j = g([h \circ \phi_+ \circ a_j])$ and $\beta'_j = g([h \circ \phi_+ \circ b_j])$ for $1 \leq j \leq l$. Likewise $\prod_{j=1}^l [\alpha'_j, \beta'_j] = 1 \in \pi$ and, for any $1 \leq j \leq l$, α'_j is the color of the $(2j - 1)^{\text{th}}$ output of T and $\beta'_j \alpha'_j^{-1} \beta'_j^{-1}$ is the color of the $(2j)^{\text{th}}$ output of T . Therefore (T, z, g) is a special π -tangle, called *associated to the π -cobordism (M, f)* .

Note that the system of bottom (resp. upper) colors of T is equal to the system of colors of the parameterized π -surface ∂_-M (resp. ∂_+M).

LEMMA 4.24. *If two π -cobordisms are equivalent then the π -colored tangle diagrams of any of their associated special π -tangles can be obtained one from the other by a finite sequence of*

- (a) isotopies (in the class of generic tangle diagrams) which preserve the colors of the vertical segments;
- (b) moves of Figure 4.2;
- (c) Kirby 1-moves or special Kirby (± 1) -moves described in Section 4.2.4;
- (d) τ -moves depicted in Figure 4.39;
- (e) moves of Figure 4.40, where a coupon labelled with r/l means a full right/left handed rotation.

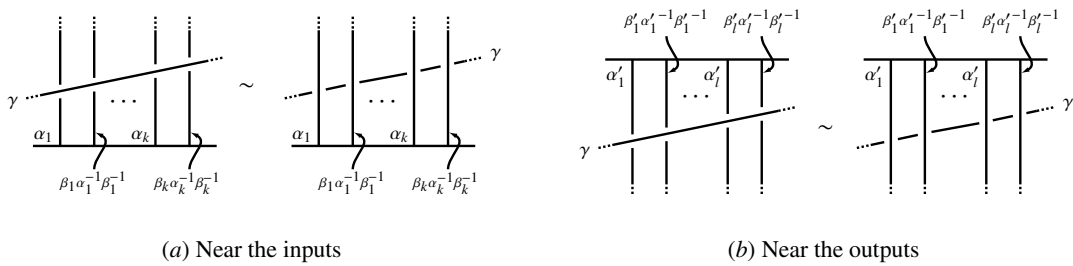

FIGURE 4.39. τ -move

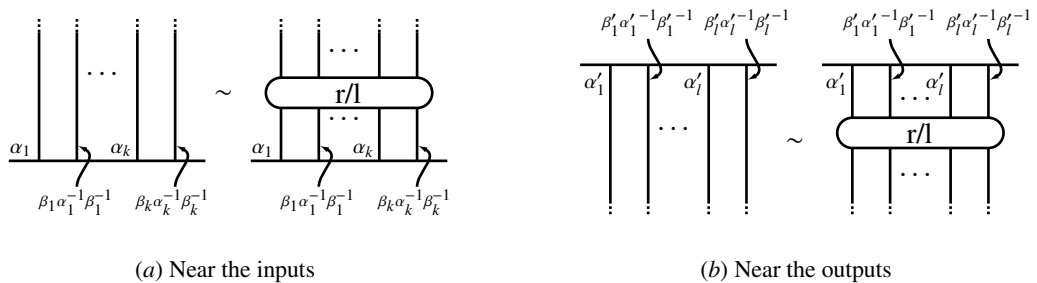

FIGURE 4.40. Full-handed rotation move

Proof. The proof is similar to that of Lemma 4.14. Suppose that (M, f) and (M', f') are equivalent π -cobordisms. Gluing (standard) handlebodies to M' and M leads to closed 3-manifolds \overline{M}' and \overline{M} which may be presented by surgery along framed links L' and L . The closed manifold \overline{M}' (resp. \overline{M}) is endowed with a ribbon graph G' (resp. G) formed by a rectangle with cap-like framed arcs attached on its top base and a rectangle with cup-like framed arcs attached on its bottom base. These ribbon graphs come from the glued (standard) handlebodies. Up to applying some isotopy to L' (resp. L), we can suppose that G' (resp. G) lies in $S^3 \setminus L'$ (resp. $S^3 \setminus L$).

Since (M', f') and (M, f) are equivalent, there exists an orientation-preserving homeomorphism $h : M \rightarrow M'$ such that $f' \circ h$ is homotopic to f relative to ∂M . The homeomorphism h extends to an orientation-preserving homeomorphism $\overline{h} : S^3_L \cong \overline{M} \rightarrow \overline{M}' \cong S^3_{L'}$. As in the proof

of Lemma 4.14, one has to decompose the homeomorphism \bar{h} into isotopies, Kirby 1-moves (in which the strings piercing the disc are not only (segments of) the framed link L but also of the ribbon graph G), and special Kirby ± 1 -moves, and then to color the diagrams representing these moves by using the morphism $\pi_1(S^3 \setminus (L \cup G)) \rightarrow \pi_1(S^3 \setminus G) \cong \pi_1(M) \xrightarrow{f_*} \pi$.

Finally, using [47, LEMMA 3.4], in which a complete list of isotopy moves for ribbon graphs is given, we get the additional moves (e) and (f). \square

Two π -cobordisms (M', f') and (M, f) are said to be *composable* if the parameterized π -surfaces $\partial_- M'$ and $\partial_+ M$ are equivalent.

Let (M', f') and (M, f) be two composable π -cobordisms. Since $\partial_- M'$ and $\partial_+ M$ are equivalent parameterized π -surfaces, there exists an orientation-preserving homeomorphism $h : \partial_+ M \rightarrow \partial_- M'$ such that $h \circ \phi_{\partial_+ M} = \phi_{\partial_- M'}$, where $\phi_{\partial_- M'}$ and $\phi_{\partial_+ M}$ are the parameterizations of the surfaces $\partial_- M'$ and $\partial_+ M$, and $f' \circ i_{\partial_- M'} \circ h$ is homotopic to $f \circ i_{\partial_+ M}$. Set $M'' = M' \cup_h M$. The maps f and f' lead to a map $f'' : M'' \rightarrow X$ well-defined up to homotopy relative to $\partial M''$. The π -cobordism (M'', f'') is called *composition* of (M', f') and (M, f) and is denoted by $(M', f') \circ (M, f)$.

LEMMA 4.25. *Let (M', f') and (M, f) be two composable π -cobordisms presented by the special π -tangles (T', g', z') and (T, z, g) respectively. Then (T', g', z') and (T, z, g) are composable and the special π -tangle $(T', g', z') \circ (T, z, g)$ presents the π -cobordism $(M', f') \circ (M, f)$.*

Proof. Since $\partial_- M'$ and $\partial_+ M$ are equivalent parameterized π -surfaces, their system of colors agree and so (T', g', z') and (T, z, g) are composable. Denote $(T'', g'', z'') = (T', g', z') \circ (T, z, g)$. Let D' and D be π -colored tangle diagrams for (T', g', z') and (T, z, g) . By [41, LEMMA 4.4], the tangle $T'T$ (whose a diagram is $D'D$) determines the manifold $M'M$. By construction of g'' from g and g' , the colors of the vertical segments of $D'D$ obtained by using g'' agree with those of D' (resp. D) obtained by using g' (resp. g). We conclude by remarking that the homomorphism g'' is in fact equals to that induced by f'' . \square

4.4.7. 3-dimensional homotopy quantum field theory for τ_H . Fix a finite type unimodular ribbon Hopf π -coalgebra $H = \{H_\alpha\}_{\alpha \in \pi}$ and a right π -integral $\lambda = (\lambda_\alpha)_{\alpha \in \pi}$ for H . We assume that $\lambda_1(\theta_1) \neq 0$ and $\lambda_1(\theta_1^{-1}) \neq 0$, where $\theta = \{\theta_\alpha\}_{\alpha \in \pi}$ denotes the twist of H .

Let (M, f) be a (pointed) π -cobordism with boundary $\partial M = (-\partial_- M) \amalg \partial_+ M$. Denote by k (resp. l) the genus of $\partial_- M$ (resp. $\partial_+ M$) and by $c_- = (\alpha_1, \beta_1, \dots, \alpha_k, \beta_k)$ (resp. $c_+ = (\alpha'_1, \beta'_1, \dots, \alpha'_l, \beta'_l)$) the system of colors of the parameterized π -surface $\partial_- M$ (resp. $\partial_+ M$). Let (T, z, g) be a special π -tangle with $2k$ inputs and $2l$ outputs which represents the π -cobordism (M, f) . Recall that c_- (resp. c_+) is the system of bottom (resp. upper) colors of (T, z, g) . Denote by n the number of circle components of T . We set

$$\psi_H(M, f) = \lambda_1(\theta_1)^{b_-(L)-nL} \lambda_1(\theta_1^{-1})^{-b_-(L)} \psi_H(T, z, g) : F_{c_+} \rightarrow F_{c_-},$$

where L is the framed link formed by the circle components of T and $\psi_H(T, z, g)$ is the map constructed in §4.4.3.

LEMMA 4.26. *The map $\psi_H(M, f)$ is well-defined and only depends on the equivalence class of the π -cobordism (M, f) . Moreover, if (M', f') and (M, f) are two composable π -cobordisms, then there exists $k \in \mathbb{k}^*$ such that:*

$$\psi_H((M', f') \circ (M, f)) = k \psi_H(M, f) \circ \psi_H(M', f').$$

Proof. Let (M, f) be a π -cobordism. Let us show that $\psi_H(M, f)$ is well-defined and only depends on the equivalence class of the π -cobordism (M, f) . Present (M, f) by a special π -tangle (T, z, g) . Let D be a π -colored diagram for (T, z, g) . By Lemma 4.22, it suffices to verify that

$J(D) = \lambda_1(\theta_1)^{b-(L)-n_L} \lambda_1(\theta_1^{-1})^{-b-(L)} \psi_H(T, z, g)$ remains unchanged when a move of type (c), (d), or (e) described in Lemma 4.24 is applied to D .

The fact that $J(D)$ is invariant when a Kirby 1-move or a special Kirby (± 1) -move is applied to D has been shown in the proof of Theorem 4.12 (these moves are local and their effects are cancelled by normalization).

Let us show that $J(D)$ remains unchanged by a τ -move near the top-line described in Figure 4.39(b). Since $\prod_{j=1}^l [\alpha'_j, \beta'_j] = 1$, the splitting rules described in Lemma 4.15 allows us to write down the algebraization (near the top-line) by using $R_{1,\gamma}$ and $R_{\gamma,1}$. Write $R_{1,\gamma} = y_1 \otimes z_\gamma$ and $R_{\gamma,1} = c_\gamma \otimes d_1$. Since $\varepsilon(S_1(y_1))z_\gamma = 1_\gamma = \varepsilon(d_1)c_\gamma$ by Lemmas 1.1(d) and 2.4(a), since the $2l$ outputs of D are the endpoints of l cup-like arcs, and by using the rules of Figures 4.5 and 4.7, the same reasoning as for the proof of (4.18) (applied with $\Delta_{c'}(S_1(y_1))$ and $\Delta_{c'}(d_1)$) gives the equalities depicted in Figure 4.41. Hence $J(D)$ remains unchanged by a τ -move near the top-line.

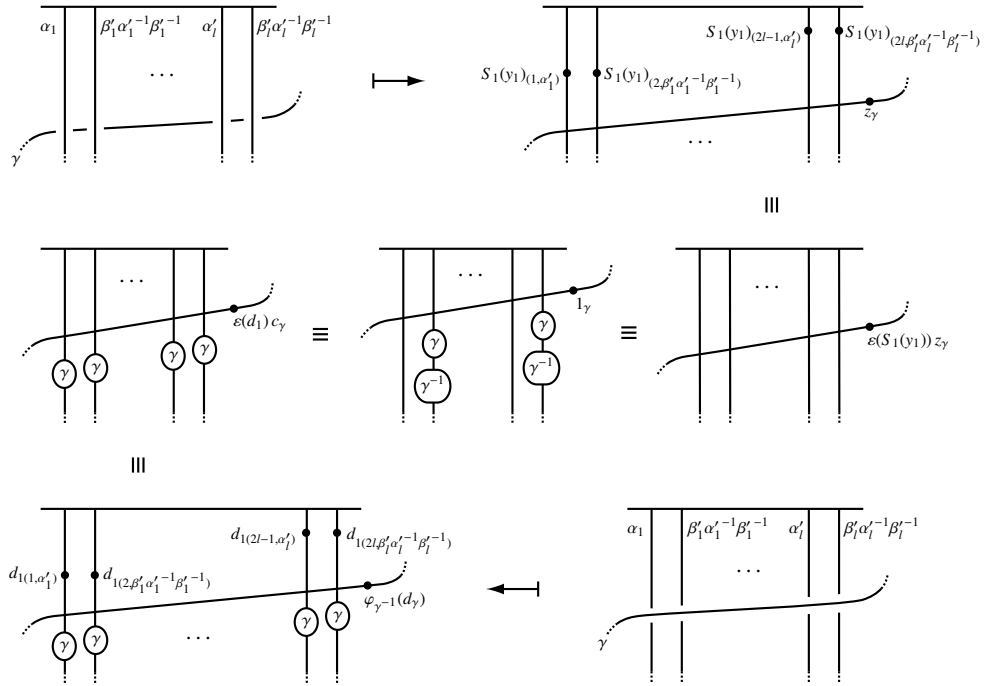

FIGURE 4.41.

The fact that $J(D)$ remains unchanged by a τ -move near the bottom-line (as described in Figure 4.40(a)) follows from the invariance of $J(D)$ by a τ -move near the top-line, see Figure 4.42. Note that it is crucial here that the coborded surfaces are connected.

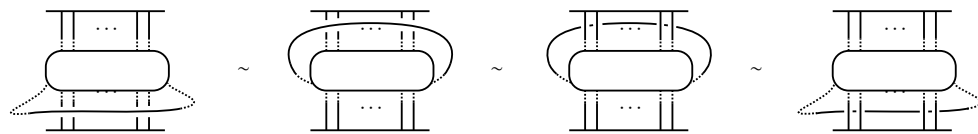

FIGURE 4.42.

Let us verify that $J(D)$ remains unchanged by a full left handed rotation near the top-line (see Figure 4.40). Recall that, by (4.8), the π -colored tangle diagrams $K_{\alpha'_1, \beta'_1 \alpha'_1^{-1} \beta'_1^{-1}, \dots, \alpha'_l, \beta'_l \alpha'_l^{-1} \beta'_l^{-1}}$ of Figure 4.17(a) and $I_{\alpha'_1, \beta'_1 \alpha'_1^{-1} \beta'_1^{-1}, \dots, \alpha'_l, \beta'_l \alpha'_l^{-1} \beta'_l^{-1}}$ of Figure 4.17(b) are related by

$$I_{\alpha'_1, \beta'_1 \alpha'_1^{-1} \beta'_1^{-1}, \dots, \alpha'_l, \beta'_l \alpha'_l^{-1} \beta'_l^{-1}} \sim \lambda_1(\theta_1)^{-1} T_{\alpha'_1, \beta'_1 \alpha'_1^{-1} \beta'_1^{-1}, \dots, \alpha'_l, \beta'_l \alpha'_l^{-1} \beta'_l^{-1}}.$$

Therefore, since an isolated trivial knot with framing 1 which is colored by $1 \in \pi$ contributes to $\lambda_1(\theta_1)$ (see Figure 4.18) and by using a τ -move near the top-line, we obtain the equalities depicted in Figure 4.43. Hence $J(D)$ remains unchanged when a full left handed rotation is applied to D near the top-line. The invariance of $J(D)$ under a full right handed rotation near the top-line or a full left/right handed rotation near the bottom-line can be done similarly.

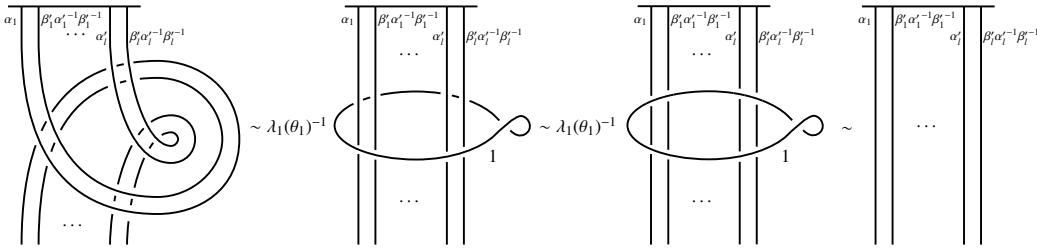

FIGURE 4.43.

Finally, the contravariance and projectivity of ψ_H with respect to the composition of π -cobordisms is a direct consequence of Lemma 4.23 and of the fact that $\lambda_1(\theta_1) \neq 0$ and $\lambda_1(\theta_1^{-1}) \neq 0$. \square

Denote by Cob_3^π the category whose objects are equivalence classes of parameterized π -surfaces and morphisms are equivalence classes of π -cobordisms. Following [48], a *homotopy quantum field theory in dimension 2 + 1* with *target space* the Eilenberg-Mac Lane space $K(\pi, 1)$ may be viewed as a projective covariant functor from the category Cob_3^π to the category $\text{Vect}_{\mathbb{k}}$ of finite-dimensional \mathbb{k} -spaces.

THEOREM 4.27. *The invariant τ_H of π -manifolds (constructed in Section 4.2) extends to a homotopy quantum field theory in dimension 2 + 1 (for connected surfaces and connected cobordisms) with target space the Eilenberg-Mac Lane space $K(\pi, 1)$.*

Proof. For any parameterized π -surface Σ , we set $\Psi_H(\Sigma) = T_c^*$ where c is the system of colors of Σ . Recall that c remains unchanged under equivalence of the parameterized π -surface Σ . For any π -cobordism (M, f) , we set

$$\Psi_H(M, f) = {}^t\psi_H(M, f) : \Psi_H(\partial_- M) \rightarrow \Psi_H(\partial_+ M),$$

where ${}^t\psi_H(M, f)$ denotes the dual map. By Lemma 4.26, $\Psi_H(M, f)$ only depends on the equivalence class of the π -cobordism (M, f) .

Let (Σ, p, g, ϕ) be a parameterized π -surface. Consider the cylinder $\Sigma \times [0, 1]$ with the product orientation, where $[0, 1]$ is oriented from left to right. The map $g : \pi_1(\Sigma, p) \rightarrow \pi$ is induced (in homotopy) by a map $\tilde{g} : \Sigma \rightarrow X$ such that $\tilde{g}(p) = x$. Denote the projection $\Sigma \times [0, 1] \rightarrow \Sigma$ by pr_Σ . Then $(\Sigma \times [0, 1], \tilde{g} \circ \text{pr}_\Sigma)$ is a π -cobordism between (Σ, p, g, ϕ) and itself which represents the identity id_Σ of (Σ, p, g, ϕ) in the category Cob_3^π . Using Lemma 4.26, there exists $k \in \mathbb{k}^*$ such that

$$\Psi_H(\text{id}_\Sigma)^2 = k \Psi_H(\text{id}_\Sigma^2) = k \Psi_H(\text{id}_\Sigma).$$

Up to multiplication by a scalar, $\Psi_H(\text{id}_\Sigma)$ is a projector acting in the vector space $\Psi_H(\Sigma)$. We denote the image of this projector by $\overline{\Psi}_H(\Sigma)$.

By Lemma 4.26, for any π -cobordism (M, f) , there exists $k, k' \in \mathbb{k}^*$ such that

$$\Psi_H(M, f) = k \Psi_H(\text{id}_{\partial_+ M}) \circ \Psi_H(M, f) = k' \Psi_H(M, f) \circ \Psi_H(\text{id}_{\partial_- M}).$$

Therefore $\Psi_H(M, f)$ maps $\overline{\Psi}_H(\partial_- M)$ into $\overline{\Psi}_H(\partial_+ M)$. We denote by $\overline{\Psi}_H(M, f)$ the restriction $\Psi_H(M, f)|_{\overline{\Psi}_H(\partial_- M)} : \overline{\Psi}_H(\partial_- M) \rightarrow \overline{\Psi}_H(\partial_+ M)$.

Using Lemma 4.26, one easily verifies that $\overline{\Psi}_H : \text{Cob}_3^\pi \rightarrow \text{Vect}_{\mathbb{k}}$ define a projective covariant functor from the category Cob_3^π to the category $\text{Vect}_{\mathbb{k}}$.

Finally, since $\overline{\Psi}_H(\emptyset) = \mathbb{k}$ and by the definitions of the maps ψ_H and of the invariant τ_H , we have that $\psi_H(M, f)$ and so $\overline{\Psi}_H(M, f)$ are multiplication (in \mathbb{k}) by $\tau_H(M, f)$ when the manifold M is closed. \square

CHAPTER 5

Kuperberg-like invariants of group-manifolds

In [21], Kuperberg constructed an invariant of 3-manifolds by presenting them by Heegaard diagrams. The aim of the present chapter is to generalize this construction to bundles over 3-manifolds.

Given a discrete group π , Kuperberg's method is generalized by presenting the base space of a principal π -bundle over a 3-manifold (called π -manifold) by a Heegaard diagram which is colored with π by using the monodromy of the bundle, and to which is associated some structure constants of an involutory Hopf π -coalgebra. We show that the Reidemeister-Singer moves colored in some sense by π report the equivalence of π -manifolds, and we verify the invariance under these moves by using the properties of involutory Hopf π -coalgebras established in Chapter 1.

This obtained invariant is not trivial (we give examples of computation for some $\mathbb{Z}/2\mathbb{Z}$ -bundles over lens spaces by using the Hopf $\mathbb{Z}/2\mathbb{Z}$ -coalgebra described in [49]) and coincide with that of Kuperberg when $\pi = 1$.

This chapter is organized as follows. In Section 5.1, we construct an invariant of π -colored Heegaard diagrams. In Section 5.2, we show that this invariant is in fact an invariant of pointed π -manifolds. Finally, in Section 5.3, we give an example of an explicit computation of such invariants.

5.1. Invariants of π -colored Heegaard diagrams

Throughout this chapter, $H = (\{H_\alpha, 1_\alpha, m_\alpha\}, \Delta, \varepsilon, S)$ will denote a finite type involutory Hopf π -coalgebra such that $\dim H_1 \neq 0$ in the ground field \mathbb{k} of H . Note that H is then semisimple and cosemisimple (by Corollary 1.30).

5.1.1. Diagrammatic formalism of Hopf group-coalgebras. The structure maps of the Hopf π -coalgebra H can be represented symbolically as in [21]. The products $m_\alpha : H_\alpha \otimes H_\alpha \rightarrow H_\alpha$, the units 1_α , the comultiplication $\Delta_{\alpha,\beta} : H_{\alpha\beta} \rightarrow H_\alpha \otimes H_\beta$, the counit $\varepsilon : H_1 \rightarrow \mathbb{k}$, and the antipode $S_\alpha : H_\alpha \rightarrow H_{\alpha^{-1}}$ are represented as in Figure 5.1(a). The inputs (incoming arrows) for the product symbols are read counterclockwise and the outputs arrows (outgoing arrows) for the comultiplication symbols are read clockwise.

The combinatorics of the diagrams involving such symbolical representations of structure maps may be thought of as (sum of) products of structure constants. For example, if $(e_i)_i$ is a basis of H_1 and $\delta_i^{j,k} \in \mathbb{k}$ are the structure constants of $\Delta_{1,1}$ defined by

$$\Delta_{1,1}(e_i) = \sum_{j,k} \delta_i^{j,k} e_j \otimes e_k,$$

then the element $C \in H_1$ represented in Figure 5.1(b) is given by $C = \sum_{i,k} \delta_i^{i,k} e_k$. Similarly, if $(f_i)_i$ is a basis of H_α and $\mu_{i,j}^k \in \mathbb{k}$ are the structure constants of m_α defined by

$$m_\alpha(f_i \otimes f_j) = \sum_k \mu_{i,j}^k f_k,$$

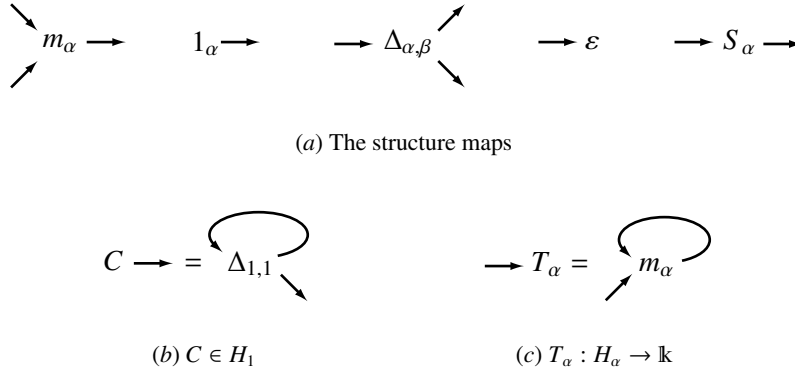

FIGURE 5.1. Diagrammatic formalism

then the morphism $T_\alpha : H_\alpha \rightarrow \mathbb{k}$ represented in Figure 5.1(c) is given by $T_\alpha(f_i) = \sum_k \mu_{k,i}^k$. Note that $T_\alpha(x) = \text{Tr}(r(x))$ for any $x \in H_\alpha$, where $r(x) \in \text{End}_{\mathbb{k}}(H_\alpha)$ denotes the right multiplication by x and Tr is the usual trace of \mathbb{k} -linear endomorphisms.

In light of the associativity and coassociativity axioms (see Section 1.1), we adopt the abbreviations of Figure 5.2.

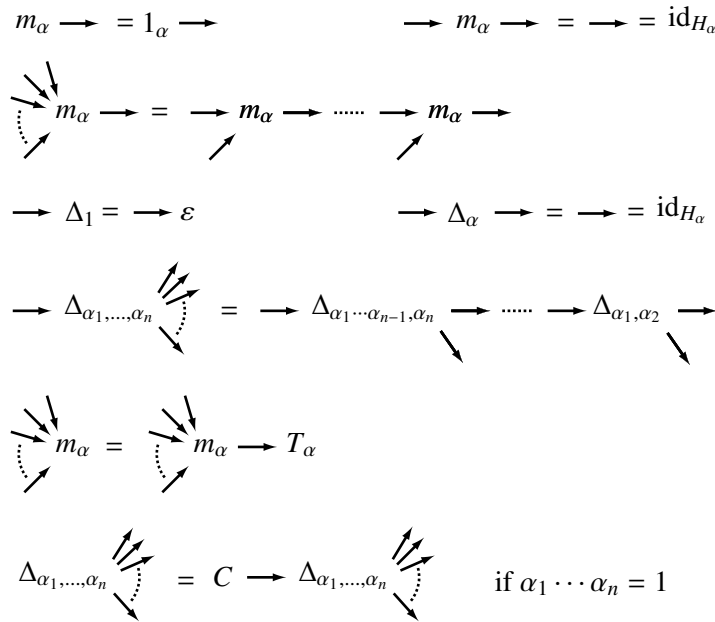

FIGURE 5.2. Diagrammatic abbreviations

LEMMA 5.1. $T = (T_\alpha)_{\alpha \in \pi}$ is a non-zero two-sided π -integral for H and C is a non-zero two-sided integral for H_1 which verify that $T_1(1_1) = \varepsilon(C) = T_1(C) = \dim H_1$. Moreover $S_1(C) = C$ and $T_{\alpha^{-1}} \circ S_\alpha = T_\alpha$ for all $\alpha \in \pi$.

Proof. Recall that H is semisimple and cosemisimple (by Corollary 1.30). Therefore, by Theorem 1.24 and Corollary 1.27, there exists a two-sided π -integral $\lambda = (\lambda_\alpha)_{\alpha \in \pi}$ for H such that $\lambda_\alpha(1_\alpha) = 1$ for all $\alpha \in \pi$ with $H_\alpha \neq 0$. Let Λ be a left π -integral for H_1 such that $\lambda_1(\Lambda) = 1$. By Lemma 1.28(b), we have that $T_\alpha(x) = \text{Tr}(r(x)) = \varepsilon(\Lambda)\lambda_\alpha(x)$ for any $x \in H_\alpha$. Therefore $T = (T_\alpha)_{\alpha \in \pi}$ is a multiple of $\lambda = (\lambda_\alpha)_{\alpha \in \pi}$ and so is a two-sided π -integral for H , which is non-zero since H_1 is semisimple and so $\varepsilon(\Lambda) \neq 0$ (by [45, THEOREM 5.1.8]). Likewise $C = \lambda_1(1_1)\Lambda = \Lambda$ (by Lemma 1.28(b) applied to the Hopf algebra H_1^*) and so C is a non-zero left integral for H_1 . Moreover C is a right integral for H_1 (since H_1 is semisimple and so its integrals are two-sided).

Since $\lambda_1(1_1) = \lambda_1(\Lambda) = 1$ and by Lemma 1.28(b), we have that $T_1(C) = T_1(1_1) = \varepsilon(C) = \varepsilon(\Lambda) = \text{Tr}(\text{id}_{H_1}) = \dim H_1$.

Since H is cosemisimple, the distinguished π -grouplike element of H is trivial (by Corollary 1.27). Therefore Theorem 1.16(c) gives that $T_{\alpha^{-1}} \circ S_\alpha = T_\alpha$ for all $\alpha \in \pi$. Finally, $S_1(C)$ is a left integral for H_1 and so there exists $k \in \mathbb{k}$ such that $S_1(C) = kC$. Then $k\varepsilon(C) = \varepsilon(S_1(C)) = \varepsilon(C)$ by Lemma 1.1(d). Therefore $k = 1$ (since $\varepsilon(C) = \dim H_1 \neq 0$) and so $S_1(C) = C$. \square

LEMMA 5.2. *The tensors represented by the two last diagrams of Figure 5.2 are cyclically symmetric.*

Proof. Let $\alpha \in \pi$. Since $(T_\beta)_{\beta \in \pi}$ is a right π -integral for H (by Lemma 5.1) and the Hopf algebra H_1 is semisimple and so unimodular, Theorem 1.16(a) gives that

$$T_\alpha(xy) = T_\alpha(S_{\alpha^{-1}}S_\alpha(y \leftarrow \varepsilon)x) = T_\alpha(yx)$$

for all $x, y \in H_\alpha$. Therefore $T_\alpha(x_1x_2 \cdots x_n) = T_\alpha(x_2 \cdots x_nx_1)$ for all $x_1, \dots, x_n \in H_\alpha$.

Since H is cosemisimple and so its distinguished π -grouplike element is trivial (by Corollary 1.27) and C is a left integral for H_1 (by Lemma 5.1), Corollary 1.18 gives that $C_{(1,\alpha)} \otimes C_{(2,\alpha^{-1})} = S_{\alpha^{-1}}S_\alpha(C_{(2,\alpha)})1_\alpha \otimes C_{(1,\alpha^{-1})} = C_{(2,\alpha)} \otimes C_{(1,\alpha^{-1})}$ for all $\alpha \in \pi$. Therefore, for all $\alpha_1, \dots, \alpha_n \in \pi$ such that $\alpha_1 \cdots \alpha_n = 1$, we obtain

$$\begin{aligned} C_{(1,\alpha_1)} \otimes \cdots \otimes C_{(n-1,\alpha_{n-1})} \otimes C_{(n,\alpha_n)} &= (C_{(1,\alpha_n^{-1})})_{(1,\alpha_1)} \otimes \cdots \otimes (C_{(1,\alpha_n^{-1})})_{(n-1,\alpha_{n-1})} \otimes C_{(2,\alpha_n)} \\ &= (C_{(2,\alpha_n^{-1})})_{(1,\alpha_1)} \otimes \cdots \otimes (C_{(2,\alpha_n^{-1})})_{(n-1,\alpha_{n-1})} \otimes C_{(1,\alpha_n)} \\ &= C_{(2,\alpha_1)} \otimes \cdots \otimes C_{(n,\alpha_{n-1})} \otimes C_{(1,\alpha_n)}. \end{aligned}$$

\square

5.1.2. Colored Heegaard diagrams. By a *Heegaard diagram*, we shall mean a triple $D = (S, u, l)$ where S is a closed, connected, and oriented surface of genus $g \geq 1$ and $u = \{u_1, \dots, u_g\}$ and $l = \{l_1, \dots, l_g\}$ are two systems of pairwise disjoint closed curves on S such that the complement to $\cup_k u_k$ (resp. $\cup_i l_i$) is connected. Note that if a sphere with g handles is cut along g disjoint circles that do not split it, then a sphere from which $2g$ disks have been deleted is obtained (since the removal of one disk decreases the Euler characteristic by 1 and cutting along a circle does not change the Euler characteristic).

The circles u_k (resp. l_i) are called the *upper* (resp. *lower*) *circles* of the diagram. By general position we can (and we always do) assume that u and l are transverse. Note that $u \cap l$ is then a finite set. The Heegaard diagram D is said to be *oriented* if all its lower and upper circles are oriented.

Let $D = (S, u, l)$ be an oriented Heegaard diagram. Denote by g the genus of S . Fix an alphabet $X = \{x_1, \dots, x_g\}$ in g letters. For any $1 \leq i \leq g$, travelling along the lower circle l_i gives a word $w_i(x_1, \dots, x_g)$ as follows:

- Start with the empty word $w_i = \emptyset$;

- Make a round trip along l_i following its orientation. Each time l_i encounters an upper circle u_k at some crossing $c \in l_i \cap u_k$ (for some $1 \leq k \leq g$), replace w_i by $w_i x_k^v$ where:

$$v = \begin{cases} +1 & \text{if } (d_c l_i, d_c u_k) \text{ is an oriented basis for } T_c S, \\ -1 & \text{otherwise;} \end{cases}$$

- After a complete turn along l_i , one gets w_j .

Note that the word w_i is well-defined up to conjugacy by some word in the letters x_1, \dots, x_g (this is due to the indeterminacy in the choice of the starting point on l_i).

We say that the Heegaard diagram D is π -colored if each upper circle u_k is provided with an element $\alpha_k \in \pi$ such that $w_i(\alpha_1, \dots, \alpha_g) = 1 \in \pi$ for all $1 \leq i \leq g$. The system $\alpha = (\alpha_1, \dots, \alpha_g)$ is called the *color* of D .

Two π -colored Heegaard diagrams are said to be *equivalent* if one can be obtained from the other by a finite sequence of the following moves (or their inverse):

TYPE I: HOMEOMORPHISM OF THE SURFACE. By using an orientation-preserving homeomorphism of a (closed, connected, and oriented) surface S to a (closed, connected, and oriented) surface S' , the upper (resp. lower) circles on S are carried to the upper (resp. lower) circles on S' . The colors of the upper circles remain unchanged.

TYPE II: ORIENTATION REVERSAL. The orientation of an upper or lower circle is changed to its opposite. For an upper circle u_i , its color α_i is changed to its inverse α_i^{-1} .

TYPE III: ISOTOPY OF THE DIAGRAM. We isotop the lower circles of the diagram relative to the upper circles. If this isotopy is in general position, it reduces to a sequence of two-point moves shown in Figure 5.3. The colors of the upper circles remain unchanged.

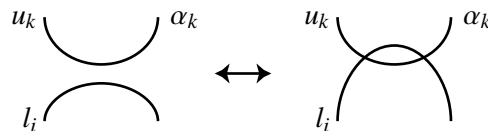

FIGURE 5.3. Two-point move

TYPE IV: STABILIZATION. We remove a disk from S which is disjoint from all upper and lower circles and replace it by a punctured torus with one upper and one lower (oriented) circles. One of them corresponds to the standard meridian and the other to the standard longitude of the added torus, see Figure 5.4. The added upper circle is colored with $1 \in \pi$.

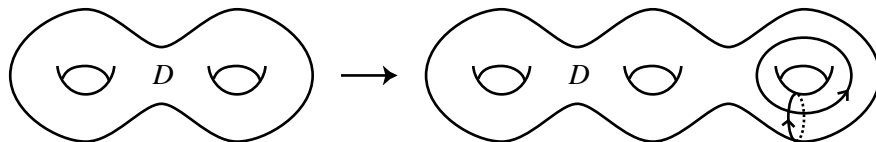

FIGURE 5.4. Stabilization

TYPE V: SLIDING A CIRCLE PAST ANOTHER. Let C_1 and C_2 be two circles of a π -colored Heegaard diagram, both upper or both lower and let b be a band on S which connects C_1 to C_2 (that is, $b : I \times I \rightarrow S$ is an embedding of $[0, 1] \times [0, 1]$ for which $b(I \times I) \cap C_i = b(i \times I)$, $i = 1, 2$) but does not cross any other circle. The circle C_1 is replaced by

$$C'_1 = C_1 \#_b C_2 = C_1 \cup C_2 \cup b(I \times \partial I) \setminus b(\partial I \times I).$$

The circle C_2 is replaced by a copy C'_2 of itself which is slightly isotoped such that it has no point in common with C'_1 . The new circle C'_1 (resp. C'_2) inherits of the orientation induced by C_1 (resp. C_2), see Figure 5.5.

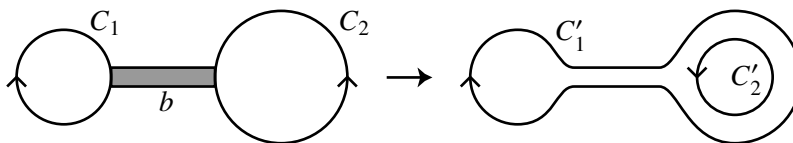

FIGURE 5.5. Circle slide

If the two circles are both lower, then the colors of the upper circle remain unchanged. Suppose that the two circles are both upper, say $C_1 = u_i$ and $C_2 = u_j$ with colors α_i and α_j respectively. Up to first applying a move of type II to u_i and/or u_j , we can assume that $(d_p b(\cdot, \frac{1}{2}), d_p u_i)$ is a negatively-oriented basis for $T_p S$ and $(d_q b(\cdot, \frac{1}{2}), d_q u_j)$ is a positively-oriented basis for $T_q S$, where $p = b(0, \frac{1}{2}) \in u_i$ and $q = b(1, \frac{1}{2}) \in u_j$. Then the color of $u'_i = C'_1$ is α_i and the color of $u'_j = C'_2$ is $\alpha_i^{-1} \alpha_j$. The colors of the other upper circles remain unchanged.

One can remark that all these moves transform a π -colored Heegaard diagram into another π -colored Heegaard diagram. Indeed, for a move of type I, each word w_i is replaced by a conjugate of itself. For a move of type II applied to an upper circle u_k , each word $w_i(x_1, \dots, x_k, \dots, x_g)$ is replaced by a conjugate of $w_i(x_1, \dots, x_k^{-1}, \dots, x_g)$. For a move of type II applied to a lower circle l_i , the word w_i is replaced by a conjugate of w_i^{-1} . For a move of type III between u_k and l_i , the word w_i is replaced by a conjugate of itself from which $x_k x_k^{-1}$ or $x_k^{-1} x_k$ has been inserted. For a move of type IV, the new word $w_{g+1}(x_1, \dots, x_{g+1})$ is $x_{g+1}^{\pm 1}$. For a move of type V applied to two lower circles, say l_i slides past l_j , the word w_i is replaced by a conjugate of itself from which a conjugate of $w_j^{\pm 1}$ has been inserted and the other words remain unchanged (up to conjugation). For a move of type V applied to two upper circles, say u_i slides past u_j , each word $w_k(x_1, \dots, x_j, \dots, x_g)$ is replaced by a conjugate of $w_k(x_1, \dots, x_i x_j, \dots, x_g)$ (see the assumptions on the orientation of the circles u_i and u_j). Therefore the conditions $w_i(\alpha_1, \dots, \alpha_g) = 1$ are still verified when performing one of these moves.

5.1.3. Invariants of π -colored Heegaard diagrams. Let $D = (S, u, l)$ be a π -colored Heegaard diagram with color $\alpha = (\alpha_1, \dots, \alpha_g)$.

- (A) To each upper circle u_k , we associate the tensor of Figure 5.6(a), where c_1, \dots, c_n are the crossings between u_k and l which appear in this order when making a round trip along u_k following its orientation. Since this tensor is cyclically symmetric (see Lemma 5.2), this assignment does not depend on the choice of the starting point on u_k .

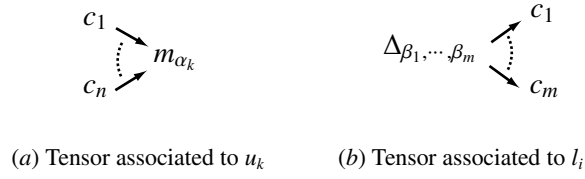
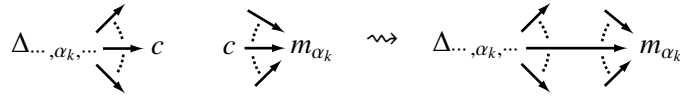

FIGURE 5.6.

(B) To each lower circle l_i , we associate the tensor of Figure 5.6(b), where c_1, \dots, c_m are the crossings between l_i and u which appear in this order when making a round trip along l_i following its orientation, and the $\beta_j \in \pi$ are defined as follows: if l_i intersects u_k at c_j , then $\beta_j = \alpha_k^\nu$ with $\nu = +1$ if $(d_{c_j}l_i, d_{c_j}u_k)$ is an oriented basis for $T_{c_j}S$ and $\nu = -1$ otherwise. Note that $\beta_1 \cdots \beta_m = w_i(\alpha_1, \dots, \alpha_g) = 1$ and so the tensor associated to l_i is well defined. Since this tensor is cyclically symmetric (see Lemma 5.2), this assignment does not depend on the choice of the starting point on l_i .

(C) Let c be a crossing point between an upper and a lower circle, say between u_k and l_i . Let ν be as in Step (B). If $\nu = +1$, we contract the tensors assigned to l_i and u_k as follows:



If $\nu = -1$, we contract the tensors assigned to l_i and u_k as follows:

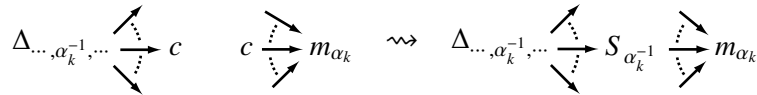

(D) After all contractions, one gets $Z(D) \in \mathbb{k}$.

We set

$$K_H(D) = (\dim H_1)^g Z(D).$$

THEOREM 5.3. *Let $H = \{H_\alpha\}_{\alpha \in \pi}$ be a finite type involutory Hopf π -coalgebra with $\dim H_1 \neq 0$ in the ground field \mathbb{k} of H . Then K_H is an invariant of π -colored Heegaard diagrams.*

Proof. We have to verify that K_H is invariant under the moves of type I-V. Clearly, K_H is invariant under a move of type I.

Consider a move of type II applied to an upper u_k circle with color α_k , that is, u_k is replaced by $u'_k = u_k$ with the opposite orientation and with color α_k^{-1} . Let c_1, \dots, c_n are the crossings between u_k and the lower circles which appear in this order following the orientation. Then the tensor associated to u_k (resp. u'_k) is:

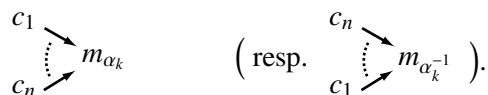

Recall that the contraction rule applied to a crossing point $c \in u_k \cap l_i$ is:

$$\Delta_{\dots, \alpha_k^\nu, \dots} \xrightarrow{\phi} m_{\alpha_k}$$

where $\nu = +1$ and $\phi = \text{id}_{H_{\alpha_k}}$ if $(d_c l_i, d_c u_k)$ is a positively-oriented basis of $T_p S$ and $\nu = -1$ and $\phi = S_{\alpha_k^{-1}}$ otherwise. Then the contraction rule applied to the corresponding crossing point $c' \in u'_k \cap l_i$ is:

$$\Delta_{\dots, \alpha_k^\nu, \dots} \xrightarrow{\psi} m_{\alpha_k^{-1}}$$

where $\psi = \text{id}_{H_{\alpha_k^{-1}}}$ if $(d_c l_i, d_c u'_k)$ is a positively-oriented basis of $T_p S$ and $\psi = S_{\alpha_k}$ otherwise. Now $\psi = \phi \circ S_{\alpha_k}$ since the antipode is involutory. Therefore the invariance follows from the equality:

$$\begin{array}{ccc} c_n \longrightarrow S_{\alpha_k} & \xrightarrow{\quad} & m_{\alpha_k^{-1}} \\ c_1 \longrightarrow S_{\alpha_k} & \xrightarrow{\quad} & \end{array} = \begin{array}{ccc} c_1 \longrightarrow & & m_{\alpha_k} \\ c_n \longrightarrow & & \end{array}$$

which comes from the anti-multiplicativity of the antipode (see Lemma 1.1(a)) and the fact that $T_{\alpha^{-1}} \circ S_{\alpha} = T_{\alpha}$ for any $\alpha \in \pi$ (by Lemma 5.1).

For a move of type II applied to a lower circle, the invariance follows from the equality:

$$\Delta_{\beta_1, \dots, \beta_m} \xrightarrow{\quad} m_{\alpha} = \Delta_{\beta_1^{-1}, \dots, \beta_m^{-1}} \xrightarrow{\quad} m_{\alpha}$$

which comes from the anti-comultiplicativity of the antipode (see Lemma 1.1(c)) and the fact that $S_1(C) = C$ (by Lemma 5.1).

Consider now a two-point move between an upper circle with color α and a lower circle. Up to first applying a move of type II, we can consider that these two circles are oriented so that the invariance is a consequence of the following equality:

$$\Delta_{\dots, \alpha, \alpha^{-1}, \dots} \xrightarrow{S_{\alpha^{-1}}} m_{\alpha} = \Delta_{\dots, 1, \dots} \xrightarrow{\varepsilon} m_{\alpha} = \Delta_{\dots, \dots} \xrightarrow{\quad} m_{\alpha}$$

which comes from (1.5).

A move of type IV contributes $C \rightarrow T_1 = \dim H_1$ (see Lemma 5.1) to $Z(D)$, which is cancelled by normalization.

Consider a move of type V applied to two upper circles, say u_i (with color α_i) slides past u_j (with color α_j). We assume, as a representative case, that both circles have three crossings with

the lower circles:

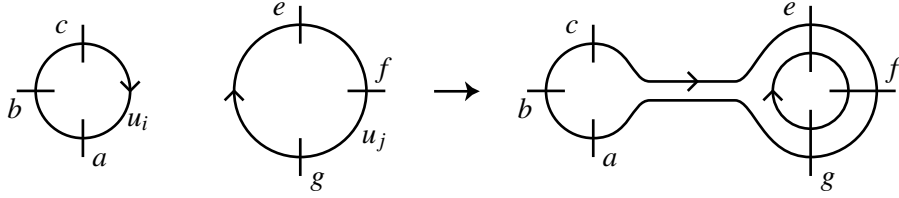

Using the anti-multiplicativity of the antipode (which allows us to consider only the positively-oriented case of the contraction rule), we have that the following factor of $Z(D)$:

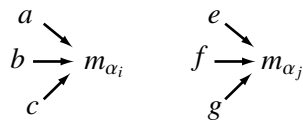

is replaced by:

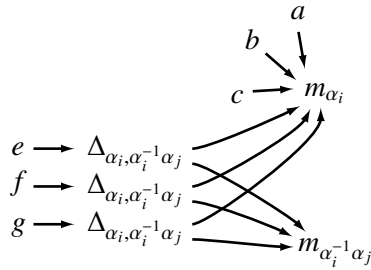

By using the multiplicativity of the comultiplication and the fact that $(T_\alpha)_{\alpha \in \pi}$ is a left π -integral for H (see Lemma 5.1), we obtain that these two factors are equal, see Figure 5.7.

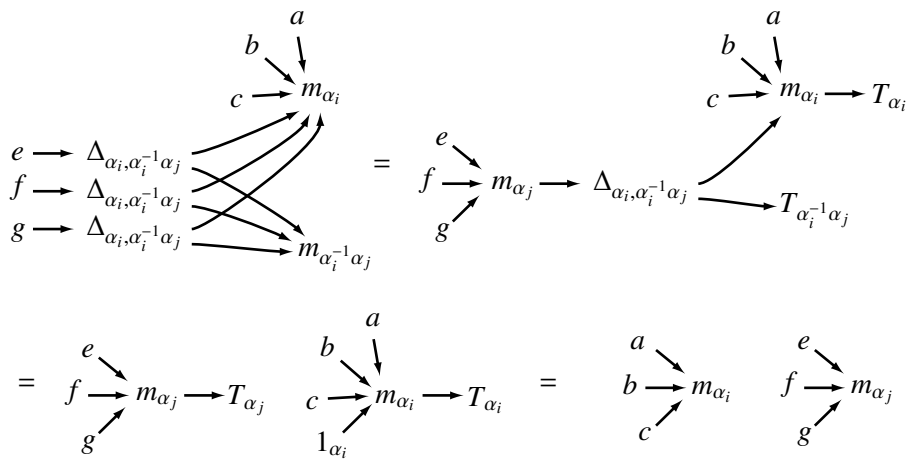

FIGURE 5.7.

Finally, suppose that a lower circle slides past another lower circle. We assume, as a representative case, that these two circles have both three crossings with the upper circles. Let $\alpha_1, \alpha_2, \alpha_3$ (resp. $\beta_1, \beta_2, \beta_3$) be the colors of the upper circles intersected (following the orientation) by the

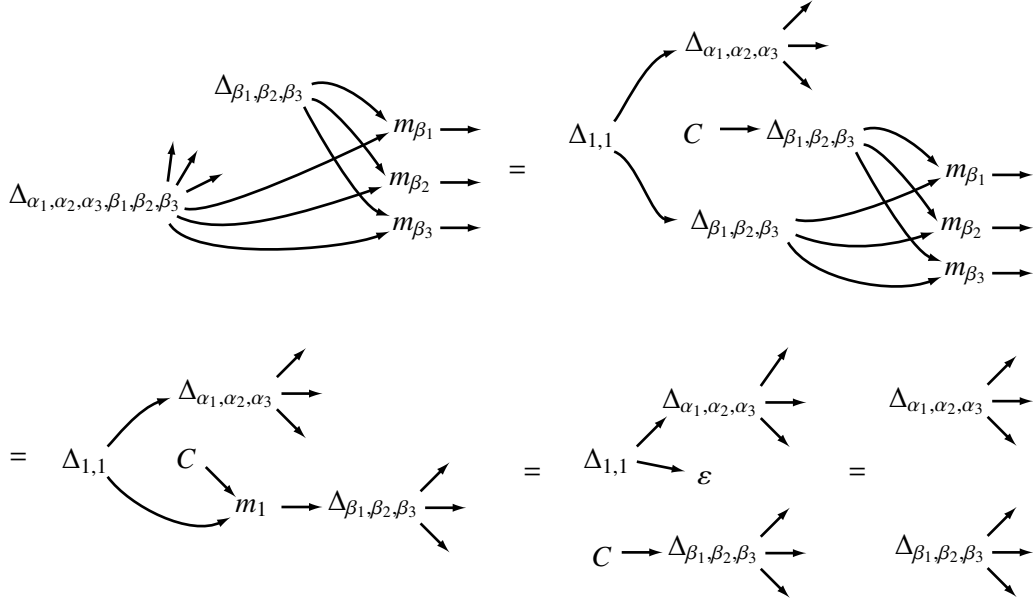

FIGURE 5.8.

first (resp. second) lower circle considered. Then the invariance follows from the equality of Figure 5.8 which comes from the multiplicativity of the comultiplication and the fact that C is a right integral for H_1 (see Lemma 5.1). This completes the proof of the theorem. \square

Recall that if π is abelian, then a Hopf π -coalgebra is always crossed (e.g., by setting $\varphi_\beta = \text{id}$).

LEMMA 5.4. *If the Hopf π -coalgebra $H = \{H_\alpha\}_{\alpha \in \pi}$ is crossed (for example when π is abelian), then $K_H(D)$ does not depend on the conjugacy class of the color of the π -colored Heegaard diagram D .*

Proof. Suppose that $H = \{H_\alpha\}_{\alpha \in \pi}$ admits a crossing $\varphi = \{\varphi_\beta : H_\alpha \rightarrow H_{\beta\alpha\beta^{-1}}\}_{\alpha, \beta \in \pi}$. Let $D = (S, u, l)$ be a π -colored Heegaard diagram of genus g with color $\alpha = (\alpha_1, \dots, \alpha_g)$. Fix $\beta \in \pi$. Then $\beta\alpha\beta^{-1} = (\beta\alpha_1\beta^{-1}, \dots, \beta\alpha_g\beta^{-1})$ is another color of (S, u, l) . We denote this new π -colored Heegaard diagram by D^β . We have to verify that $K_H(D^\beta) = K_H(D)$.

Let $1 \leq k, i \leq g$ and denote by c_1, \dots, c_n (resp. c'_1, \dots, c'_m) the crossings between u_k and l (resp. l_i and u) which appear in this order when making a round trip along u_k (resp. l_i) following its orientation. Recall that, for D (resp. D^β), the tensor of Figure 5.9(a) (resp. Figure 5.9(b)) is associated to the upper circle u_k , and the tensor of Figure 5.9(c) (resp. Figure 5.9(d)) is associated to the lower circle l_i where, if l_i intersects some u_n at d_j , $\beta_j = \alpha_n^\nu$ with $\nu = 1$ if $(d_j l_i, d_j u_n)$ is an oriented basis for $T_{d_j} S$ and $\nu = -1$ otherwise.

By Lemma 2.12, since H is cosemisimple, the morphism $\widehat{\varphi} : \pi \rightarrow \mathbb{k}^*$ of Corollary 2.2 is trivial and so $\varphi_\beta(C) = C$ (by Lemma 2.3(a)) and $T_{\beta\alpha\beta^{-1}}\varphi_\beta = T_\alpha$ for all $\alpha \in \pi$ (by Corollary 2.2). Therefore, using (2.1) and (2.2), we have the equalities of Figure 5.10.

Hence, since $\varphi_\beta = \varphi_{\beta^{-1}} = \text{id}_{H_\alpha}$ and $S_{\beta\alpha\beta^{-1}}\varphi_\beta = \varphi_\beta S_\alpha$ for all $\alpha \in \pi$ by (2.4) and Lemma 2.1, contracting the tensors associated to D^β and D by using rules of Step (C) leads to the same scalar $Z(D^\beta) = Z(D)$. Finally $K_H(D^\beta) = (\dim H_1)^g Z(D^\beta) = (\dim H_1)^g Z(D) = K_H(D)$. \square

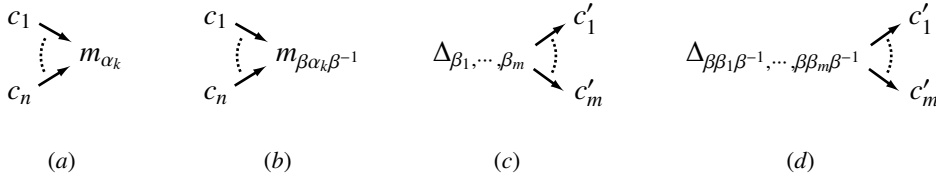

FIGURE 5.9.

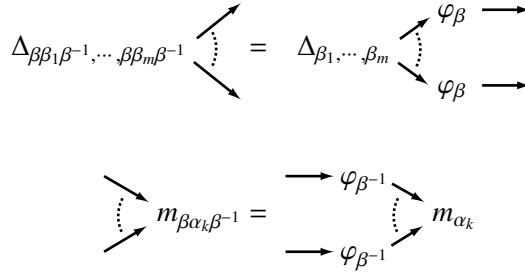

FIGURE 5.10.

5.2. Invariants of pointed π -manifolds

In this section, we show that the invariant of π -colored Heegaard diagrams constructed in Section 5.1 allows us to define an invariant K_H of pointed π -manifolds. When the Hopf π -coalgebra $H = \{H_\alpha\}_{\alpha \in \pi}$ is crossed, K_H is an invariant of π -manifolds.

5.2.1. Heegaard diagram of pointed π -manifolds. We first recall that a *Heegaard splitting of genus g* of a closed, connected, and oriented 3-manifold M is an ordered pair (M_u, M_l) of submanifolds of M , both homeomorphic to a handlebody of genus g , such that $M = M_u \cup M_l$ and $M_u \cap M_l = \partial M_u = \partial M_l$. The handlebody M_u (resp. M_l) is called *upper* (resp. *lower*) and the surface $\partial M_u = \partial M_l$ is called a *Heegaard surface* (of genus g) for M .

It is well known that every closed, connected, and oriented 3-manifold M has a Heegaard splitting (e.g., by taking a closed regular neighborhood of the one-dimensional skeleton of a triangulation of M and the closure of its complement).

Let (M_u, M_l) be a Heegaard splitting of genus g of a closed, connected, and oriented 3-manifold M . Since M_u is homeomorphic to a handlebody of genus g , there exists a finite collection $\{D_1, \dots, D_g\}$ of pairwise disjoint properly embedded 2-disks in M_u which cut M_u into a 3-ball. Likewise, there exists a finite collection $\{D'_1, \dots, D'_g\}$ of pairwise disjoint properly embedded 2-disks in M_l which cut M_l into a 3-ball. For $1 \leq i \leq g$, set $u_i = \partial D_i$ and $l_i = \partial D'_i$. We can (and we do) suppose that these circles meet transversely. Denote the Heegaard surface $M_u \cap M_l$ by S . It is oriented as follows: for any point $p \in S$, a basis (e_1, e_2) of $T_p S$ is positive if, when completing (e_1, e_2) with a vector e_3 pointing from M_l to M_u , we obtain a positively-oriented a basis (e_1, e_2, e_3) of $T_p M$. Then $D = (S, u = \{u_1, \dots, u_g\}, l = \{l_1, \dots, l_g\})$ is a Heegaard diagram in the sense of Section 5.1.2. Such a Heegaard diagram is called a *Heegaard diagram (of genus g) of M* .

5.2.2. Kuperberg-like invariants of pointed π -manifolds. Let (M, x, f) be a pointed π -manifold. Let $D = (S, u, l)$ be a Heegaard diagram of genus g of M . Recall that $S = \partial M_u = \partial M_l$ where

(M_u, M_l) is a Heegaard splitting of M . We arbitrarily orient the upper and lower circles so that D is oriented. We can (and we do) assume that $x \in S \setminus \{u, l\}$.

Since $S \setminus u$ is homeomorphic to a sphere from which $2g$ disks have been deleted, there exists g pairwise disjoint (except in x) loops $\gamma_1, \dots, \gamma_g$ on (S, x) such that, for any $1 \leq i \leq g$,

- γ_i intersects the upper circle u_i in exactly one point p_i in such a way that $(d_{p_i}\gamma_i, d_{p_i}u_i)$ is a positively-oriented basis of $T_{p_i}S$;
- γ_i does not intersect any other upper circle.

Then the homotopy classes $a_i = [\gamma_i] \in \pi_1(M, x)$ do not depend on the choice of the loops γ_i verifying the above conditions (since each γ_i is homotopic to a unique leaf of the x -based g -leafed rose formed by the core of the handlebody M_u). Moreover, by the Seifert-Van Kampen Theorem, we have the presentation

$$\pi_1(M, x) = \langle a_1, \dots, a_g \mid w_1(a_1, \dots, a_g), \dots, w_g(a_1, \dots, a_g) \rangle,$$

where the words $w_i(x_1, \dots, x_g)$ are defined as in Section 5.1.2.

For any $1 \leq i \leq g$, set $\alpha_i = f(a_i) \in \pi$. Then $\alpha = (\alpha_1, \dots, \alpha_g)$ is a color of the oriented Heegaard diagram D . We say that the (oriented) Heegaard diagram D of M is *colored by f* .

Finally, we set

$$K_H(M, x, f) = K_H(D),$$

where K_H is the invariant of π -colored Heegaard diagrams of Theorem 5.3.

THEOREM 5.5. *Let $H = \{H_\alpha\}_{\alpha \in \pi}$ be a finite type involutory Hopf π -coalgebra with $\dim H_1 \neq 0$ in the ground field \mathbb{k} of H . Then K_H is an invariant of pointed π -manifolds.*

When $\pi = 1$, one recovers the Kuperberg invariant [21] of 3-manifolds.

We show in Section 5.3 that the invariant K_H is not trivial.

Proof. Let (M, x, f) and (M', x', f') be two equivalent pointed π -manifolds. Let D (resp. D') be an oriented Heegaard diagrams of M (resp. M') colored by f (resp. f'). By virtue of Theorem 5.3, it suffices to prove that D and D' are equivalent π -colored Heegaard diagrams, i.e., D can be obtained from D' by a finite sequence of moves of type I-V (or their inverses) described in Section 5.1.2.

Since (M, x, f) and (M', x', f') are equivalent pointed π -manifolds, there exists an orientation-preserving homeomorphism $h : M \rightarrow M'$ with $f(x) = x'$ and $f = f' \circ h_*$, where $h_* : \pi_1(M, x) \rightarrow \pi_1(M', x')$ is the homomorphism induced by h . By the Reidemeister-Singer Theorem (see [43, THEOREM 8] or [21, THEOREM 4.1]), there exist:

- a finite sequence $M_0 = M, M_1, \dots, M_{n-1}, M_n = M'$ of closed, connected, and oriented 3-manifolds;
- a Heegaard diagram $D_k = (S_k, u^k = \{u_1^k, \dots, u_{g_k}^k\}, l^k = \{l_1^k, \dots, l_{g_k}^k\})$ of genus g_k of M_k for each $0 \leq k \leq n$, with $D_0 = D$ and $D_n = D'$;
- a finite sequence of orientation-preserving homeomorphisms $h_1 : M_0 \rightarrow M_1, \dots, h_n : M_{n-1} \rightarrow M_n$;

such that $h = h_n \circ \dots \circ h_1$ and, for any $1 \leq k \leq n$, the diagrams D_{k-1} and D_k are related by a move (or its inverse) of the following type:

TYPE A: HOMEOMORPHISM. $S_k = h_k(S_{k-1})$, $u^k = h_k(u^{k-1})$, and $l^k = h_k(l^{k-1})$;

TYPE B: ISOTOPY. $S_k = h_k(S_{k-1})$, $u^k = h_k(u^{k-1})$, and l^k is isotopic to $h_k(l^{k-1})$ relative to u^k ;

TYPE C: STABILIZATION. $S_k = h_k(S_{k-1}) \# T^2$, $u^k = h_k(u^{k-1}) \cup \{C_1\}$, and $l^k = h_k(l^{k-1}) \cup \{C_2\}$, where T^2 is a torus and $\{C_1, C_2\}$ is the set formed by the standard meridian and longitude of T^2 ;

TYPE D: LOWER CIRCLE SLIDE. $S_k = h_k(S_{k-1})$, $u^k = h_k(u^{k-1})$, and l^k is obtained from $h_k(l^{k-1})$ by sliding one circle of $h_k(l^{k-1})$ past another circle of $h_k(l^{k-1})$, avoiding the other upper and lower circles of $h_k(S_{k-1})$;

TYPE E: UPPER CIRCLE SLIDE. $S_k = h_k(S_{k-1})$, $l^k = h_k(l^{k-1})$, and u^k is obtained from $h_k(u^{k-1})$ by sliding one circle of $h_k(u^{k-1})$ past another circle of $h_k(l^{k-1})$, avoiding the other upper and lower circles of $h_k(S_{k-1})$.

Set $x_0 = x \in M_0$ and define $x_k = h_k \circ \cdots \circ h_1(x) \in M_k$ for any $1 \leq k \leq n$. Note that $x_n = x'$ since $h(x) = x'$. Without loss of generality, we can assume that $x_k \in S_k \setminus \{u^k, l^k\}$. Set $f_0 = f : \pi_1(M_0, x_0) \rightarrow \pi$ and define $f_k = f \circ (h_k \circ \cdots \circ h_1)_*^{-1} : \pi_1(M_k, x_k) \rightarrow \pi$ for any $1 \leq k \leq n$. Since $f = h_* \circ f'$, we have that $f_n = f'$.

We arbitrarily orient the upper circles u_i^k and the lower circles l_i^k (so that each Heegaard diagram D_k is oriented) and denote by $\alpha^k = (\alpha_1^k, \dots, \alpha_{g_k}^k)$ the coloration of the diagram D_k by the homomorphism f_k .

Up to applying some moves of type II or to well-choosing the orientation of the added circles in a stabilization move (or its inverse), we can assume that the orientation of the upper and lower circles are transported by the homeomorphisms h_i . Note that if we change the orientation of an upper circle u_i^k to its inverse, then the color $\alpha_i^k = f([\gamma_i^k])$ is replaced by $f([\gamma_i^k]^{-1}) = (\alpha_i^k)^{-1}$, where γ_i^k is a loop on (S_k, x_k) which crosses (in a positively-oriented way) the upper circle u_i^k in exactly one point and does not intersect any other upper circle.

We have to verify that, for any $1 \leq k \leq n$, the colors of the diagrams D_{k-1} and D_k are related as described in the moves of type I-V of Section 5.1.2. Fix $1 \leq k \leq n$.

Suppose that D_k is obtained from D_{k-1} by a move of type A. Let $1 \leq i \leq g_k = g_{k-1}$ and γ_i^{k-1} be a loop on (S_{k-1}, x_{k-1}) which crosses (in a positively-oriented way) the upper circle u_i^{k-1} in exactly one point and does not intersect any other upper circle of D_{k-1} . Then $\gamma_i^k = h_k(\gamma_i^{k-1})$ is a loop on (S_k, x_k) which crosses (in a positively-oriented way) the upper circle $h_k(u_i^{k-1}) = u_i^k$ in exactly one point and does not intersect any other upper circle of D_k . Therefore

$$\alpha_i^k = f_k([\gamma_i^k]) = f_k([h_k(\gamma_i^{k-1})]) = f_k \circ (h_k)_*([\gamma_i^{k-1}]) = f_{k-1}([\gamma_i^{k-1}]) = \alpha_i^{k-1}.$$

Hence the π -colored Heegaard diagrams D_{k-1} and D_k are related by a move of type I.

Suppose that D_k is obtained from D_{k-1} by a move of type B. Then the colors of the upper circles u_i^k and u_i^{k-1} agree (by the same argument as above, since $S_k = h_k(S_{k-1})$ and $u^k = h_k(u^{k-1})$). Therefore the π -colored Heegaard diagram D_k is obtained from the π -colored Heegaard diagram D_{k-1} by a finite sequence of move of type I and III (by decomposing the isotopy into two-point moves, see §5.1.2).

Suppose that D_k is obtained from D_{k-1} by a move of type C. Since $u^k = h_k(u^{k-1}) \cup \{C_1\}$, the color of the upper circle $u_i^k = h_k(u_i^{k-1})$ agrees with those of the upper circle u_i^{k-1} for any $1 \leq i \leq g_{k-1} = g_k - 1$. Let ℓ be a path connecting the point x_k to the circle C_2 which does not intersect any upper circle of D_k . Then the loop $\ell^{-1}C_2\ell$ crosses C_1 in exactly one point and does not intersect any other upper circle of D_k . Set $\nu = +1$ if $\ell^{-1}C_2\ell$ crosses C_1 in a positively-oriented way and $\nu = -1$ otherwise. Therefore

$$\alpha_{g_k}^k = f_k([\ell^{-1}C_2\ell]) = f_k([\ell^{-1}C_2\ell])^\nu.$$

Now the circle C_2 is contractible in M_k . Thus $[\gamma^{-1}C_2\gamma] = 1 \in \pi_1(M_k, x_k)$ and so $\alpha_{g_k}^k = 1 \in \pi$. Hence the π -colored Heegaard diagram D_k is obtained from the π -colored Heegaard diagram D_{k-1} by a move of type I and then a move of type IV.

Suppose that D_k is obtained from D_{k-1} by a move of type D. Since $S_k = h_k(S_{k-1})$ and $u^k = h_k(u^{k-1})$, the colors of the upper circles of D_k and D_{k-1} agree. Then the π -colored Heegaard

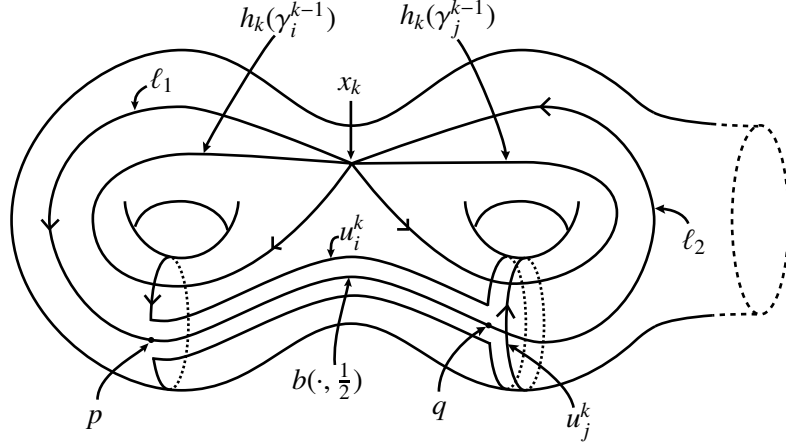

FIGURE 5.11.

diagram D_k is obtained from the π -colored Heegaard diagram D_{k-1} by a move of type I and then a move of type V.

Finally, suppose that D_k is obtained from D_{k-1} by a move of type E, i.e., suppose that u^k is obtained from $h_k(u^{k-1})$ by sliding a circle $h_k(u_i^{k-1})$ past another circle $h_k(u_j^{k-1})$. Let $b : I \times I \rightarrow S_k$ be a band which connects $h_k(u_i^{k-1})$ to $h_k(u_j^{k-1})$ (that is, $b(I \times I) \cap h_k(u_i^{k-1}) = b(0 \times I)$ and $b(I \times I) \cap h_k(u_j^{k-1}) = b(1 \times I)$) but does not intersect any other circle. We can also assume that $x_k \notin b(I \times I)$. Then

$$u_i^k = h_k(u_i^{k-1}) \#_b h_k(u_j^{k-1}) = h_k(u_i^{k-1}) \cup h_k(u_j^{k-1}) \cup b(I \times \partial I) \setminus b(\partial I \times I)$$

and u_j^k is a copy $h_k(u_j^{k-1})$ which is slightly isotoped such that it has no point in common with u_i^k . Set $p = b(0, \frac{1}{2}) \in h_k(u_i^{k-1})$ and $q = b(1, \frac{1}{2}) \in h_k(u_j^{k-1})$. Up to first applying a move of type II to u_i^{k-1} and/or u_j^{k-1} , we can assume that $(d_p b(\cdot, \frac{1}{2}), d_p h_k(u_i^{k-1}))$ is a negatively-oriented basis for $T_p S_k$ and $(d_q b(\cdot, \frac{1}{2}), d_q h_k(u_j^{k-1}))$ is a positively-oriented basis for $T_q S_k$. Then the orientations of u_i^k induced by $h_k(u_i^{k-1})$ and $h_k(u_j^{k-1})$ coincide and u_i^k is provided with this orientation. Let γ_i^{k-1} (resp. γ_j^{k-1}) be a loop on (S_{k-1}, x_{k-1}) which crosses (in a positively-oriented way) the upper circle u_i^{k-1} (resp. u_j^{k-1}) in exactly one point and does not intersect any other upper circle of D_{k-1} neither the band $b(I \times I)$. Let $\ell_1 : I \rightarrow S_k$ be a path with $\ell_1(0) = x_k$ and $\ell_1(1) = p$ which does not intersect any upper circle of D_k and such that $(d_p \ell_1, d_p h_k(u_i^{k-1}))$ is a negatively-oriented basis for $T_p S_k$. Let $\ell_2 : I \rightarrow S_k$ be a path with $\ell_2(0) = q$ and $\ell_2(1) = x_k$ which does not intersect any upper circle of D_k and such that $(d_q \ell_2, d_q h_k(u_j^{k-1}))$ is a positively-oriented basis for $T_q S_k$, see Figure 5.11.

Set $\gamma_i^k = h_k(\gamma_i^{k-1})$ (resp. $\gamma_j^k = \ell_2 b(\cdot, \frac{1}{2}) \ell_1$). It is a loop on (S_k, x_k) which crosses (in a positively-oriented way) the upper circle u_i^k (resp. u_j^k) in exactly one point and does not intersect any other upper circle of D_k . Therefore we have

$$\alpha_i^k = f_k([\gamma_i^k]) = f_k([h_k(\gamma_i^{k-1})]) = f_k \circ (h_k)_*([\gamma_i^{k-1}]) = f_{k-1}([\gamma_i^{k-1}]) = \alpha_i^{k-1}.$$

and, since γ_j^k is homotopic (in M_k) to the loop $h_k(\gamma_j^{k-1})h_k(\gamma_i^{k-1})^{-1}$,

$$\begin{aligned} \alpha_j^k &= f_k([\gamma_j^k]) \\ &= f_k([h_k(\gamma_j^{k-1})h_k(\gamma_i^{k-1})^{-1}]) \end{aligned}$$

$$\begin{aligned}
&= f_k \circ (h_k)_*([\gamma_j^{k-1}(\gamma_i^{k-1})^{-1}]) \\
&= f_{k-1}([\gamma_i^{k-1}]^{-1}[\gamma_j^{k-1}]) \\
&= (\alpha_i^{k-1})^{-1}\alpha_j^{k-1}.
\end{aligned}$$

Hence the π -colored Heegaard diagram D_k is obtained from the π -colored Heegaard diagram D_{k-1} by a move of type I and then a move of type V. This completes the proof of the theorem. \square

In the next corollary, we verify that if the Hopf π -coalgebra $H = \{H_\alpha\}_{\alpha \in \pi}$ is crossed, then K_H is an invariant of π -manifolds. Let (M, ξ) be a π -manifold. Choose a point \tilde{x} in the total space \tilde{M} of ξ . Denote by x the projection of \tilde{x} under the covering $\tilde{M} \rightarrow M$ and by $f : \pi_1(M, x) \rightarrow \pi$ the monodromy of ξ at \tilde{x} . This leads a pointed π -manifold (M, x, f) . When H admits a crossing, we set $K_H(M, \xi) = K_H(M, x, f)$.

COROLLARY 5.6. *Let $H = \{H_\alpha\}_{\alpha \in \pi}$ be a finite type involutory Hopf π -coalgebra with $\dim H_1 \neq 0$ in the ground field \mathbb{k} of H . If H is crossed (for example when π is abelian), then K_H is an invariant of π -manifolds.*

Proof. We have to verify that the scalar $K_H(M, x, f)$ does not depend on the choice of the base point \tilde{x} in the total space \tilde{M} of the π -manifold (M, ξ) . Let \tilde{x}' be another point in \tilde{M} . Denote by x' the projection of \tilde{x}' under the covering $\tilde{M} \rightarrow M$ and by $f' : \pi_1(M, x') \rightarrow \pi$ the monodromy of ξ at \tilde{x}' . Since M is connected, there exists a path $\gamma : [0, 1] \rightarrow M$ connecting $x = \gamma(0)$ to $x' = \gamma(1)$. Pushing x to x' along γ inside a tubular neighborhood of $\text{Im}(\gamma)$ in M yields an orientation-preserving self-homeomorphism h of M such that the induced homomorphism $h_* : \pi_1(M, x) \rightarrow \pi_1(M, x')$ is given by $h_*([\ell]) = [\gamma\ell\gamma^{-1}]$ for any loop ℓ in (M, x) . Since π is a discrete group, the path $\gamma : [0, 1] \rightarrow M$ uniquely lifts to a path $\tilde{\gamma} : [0, 1] \rightarrow \tilde{M}$ such that $\tilde{\gamma}(0) = \tilde{x}$. Since \tilde{x}' and $\tilde{\gamma}(1)$ belong to the same fiber (over x'), there exists $\beta \in \pi$ such that $\tilde{\gamma}(1) = \beta \cdot \tilde{x}'$. Using the definition of the monodromy, we obtain that $f' = \beta^{-1}(f \circ h_*^{-1})\beta$.

Let $D = (S, u, l)$ be a Heegaard diagram of genus g of M whose upper and lower circles are arbitrarily oriented. Denote by $\alpha = (\alpha_1, \dots, \alpha_g)$ the coloration of D by f . Then the colorations of the (oriented) Heegaard diagram $h(D) = (h(S), h(u), h(l))$ by $f \circ h_*^{-1}$ or f' are respectively $\alpha = (\alpha_1, \dots, \alpha_g)$ and $\beta^{-1}\alpha\beta = (\beta^{-1}\alpha_1\beta, \dots, \beta^{-1}\alpha_g\beta)$. Hence we have that

$$\begin{aligned}
K_H(M, x', f') &= K_H(h(D)_{\beta^{-1}\alpha\beta}) \\
&= K_H(h(D)_\alpha) \quad \text{by Lemma 5.4} \\
&= K_H(D_\alpha) \quad \text{by Theorem 5.3} \\
&= K_H(M, x, f),
\end{aligned}$$

where D_α (resp. $h(D)_\alpha$, $h(D)_{\beta^{-1}\alpha\beta}$) denotes the π -colored Heegaard diagram D (resp. $h(D)$, $h(D)$) with color α (resp. α , $\beta^{-1}\alpha\beta$). \square

5.2.3. Basic properties of K_H . Let (M, x, f) be a pointed π -manifold. Recall that H^{op} and H^{cop} denotes the opposite or coopposite Hopf π -coalgebra to H (see Section 1.1). Denote by $-M$ the manifold M with the opposite orientation. Then

$$(5.1) \quad K_H(-M, x, f) = K_{H^{\text{cop}}}(M, x, f) = K_{H^{\text{op}}}(M, x, f).$$

Indeed, starting from an oriented Heegaard diagram $D = (S, u, l)$ for M , reversing the orientation of M resumes to reversing the orientation of the Heegaard surface S , and so the first equality of (5.1) may be easily obtained by reversing the orientation of the lower circles and the second one by reversing the orientation of the upper circles.

Let (M_1, x_1, f_1) and (M_2, x_2, f_2) be two pointed π -manifolds. Take closed 3-balls $B_1 \subset M_1$ and $B_2 \subset M_2$ such that $x_1 \in \partial B_1$ and $x_2 \in \partial B_2$. Glue $M_1 \setminus \text{Int}B_1$ and $M_2 \setminus \text{Int}B_2$ along a

homeomorphism $h : \partial B_1 \rightarrow \partial B_2$ chosen so that $h(x_1) = x_2$ and that the orientations in $M_1 \setminus \text{Int}B_1$ and $M_2 \setminus \text{Int}B_2$ induced by those in M_1, M_2 are compatible. This gluing yields a closed, connected, and oriented 3-manifold $M_1 \# M_2$. For $i = 1$ or 2 , consider the embeddings $j_i : M_i \setminus \text{Int}B_i \hookrightarrow M_i$ and $k_i : M_i \setminus \text{Int}B_i \hookrightarrow M_1 \# M_2$ and set $x = k_1(x_1) = k_2(x_2)$. By the Van Kampen theorem, since $\partial B_2 \cong h(\partial B_1)$ is simply-connected, there exists a unique group homomorphism $f : \pi_1(M_1 \# M_2, x) \rightarrow \pi$ such that $f \circ (k_i)_* = f_i \circ (j_i)_*$ ($i = 1, 2$). Consider the pointed π -manifold $(M_1 \# M_2, x, f)$. Then

$$(5.2) \quad K_H(M_1 \# M_2, x, f) = K_H(M_1, x_1, f_1) K_H(M_2, x_2, f_2).$$

Indeed we can choose a Heegaard diagram for M which is a connected sum of Heegaard diagrams for M_1 and M_2 and such that the colorations of these diagrams by the homomorphisms f, f_1 , or f_2 are compatible with this connected sum.

5.2.4. The invariants τ_H and K_H . Let $H = \{H_\alpha\}_{\alpha \in \pi}$ be a finite type involutory ribbon Hopf π -coalgebra such that $\dim H_1 \neq 0$ in the ground field \mathbb{k} of H and that $\lambda_1(\theta_1) \neq 0 \neq \lambda_1(\theta_1^{-1})$ for at least one (and thus all) non-zero right π -integral for H . Note that H is unimodular since it is semisimple (by Corollary 1.30). The invariants of π -manifolds τ_H (see Theorem 4.12) and K_H (see Corollary 5.6) are then well defined.

Considering [47, THEOREM 4.1.1] and [2, THEOREM 1] which relate the Turaev-Viro invariant of 3-manifolds with respectively that of Reshetikhin-Turaev [40, 47] and that of Kuperberg [21] and in view of Theorem 4.18, it seems reasonable to conjecture that, up to another choice of the normalization for τ_H ,

$$(5.3) \quad K_H(M, \xi) = \tau_H(M, \xi) \tau_H(-M, \xi)$$

for any π -manifold (M, ξ) , where $-M$ denotes the manifold M with the opposite orientation. Note that the ribbon structure is superfluous data for the computation of the left hand side of (5.3).

5.3. An example

Let $H = \{H_0, H_1\}$ be the finite type involutory Hopf $\mathbb{Z}/2\mathbb{Z}$ -coalgebra over \mathbb{C} of Example 2.18. Let us consider the lens spaces $L(2n, 1)$ for $n \geq 1$. Each of these spaces has two representations f_n^0 and f_n^1 of their fundamental group $\pi_1(L(2n, 1)) \cong \mathbb{Z}/2n\mathbb{Z}$ to $\mathbb{Z}/2\mathbb{Z}$, given by $f_n^0(1 \pmod{2n\mathbb{Z}}) = 0 \pmod{2\mathbb{Z}}$ and $f_n^1(1 \pmod{2n\mathbb{Z}}) = 1 \pmod{2\mathbb{Z}}$.

Let us recall (see, e.g., [36]) that a Heegaard diagram $\{u_1, l_1\}$ of genus 1 of the lens space $L(2n, 1)$ is given, on the torus $\mathbb{T} = \mathbb{R}^2/\mathbb{Z}^2$, by $u_1 = \mathbb{R}(0, 1) + \mathbb{Z}^2$ and $l_1 = \mathbb{R}(1, \frac{1}{2n}) + \mathbb{Z}^2$. See Figure 5.12 for the case $n = 2$.

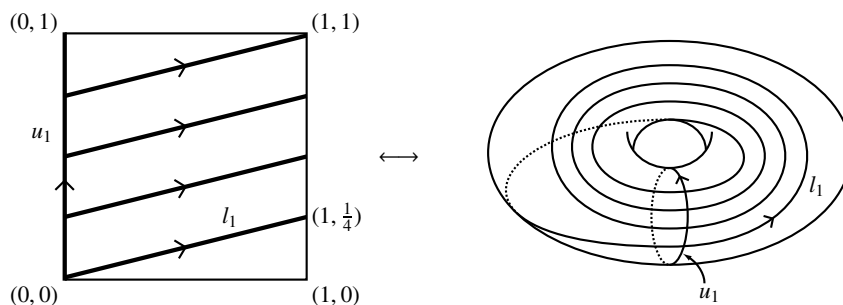

FIGURE 5.12. Heegaard diagram for $L(4, 1)$

Fix $k = 0$ or 1 and set $\alpha = f_n^k(1 \pmod{2n\mathbb{Z}}) \in \mathbb{Z}/2\mathbb{Z}$. Denote by D_α the π -colored Heegaard diagram obtained from $(\mathbb{T}, \{u_1, l_1\})$ by providing the circle u_1 with the color α . Then

$K_H(L(2n, 1), f_n^k) = \dim H_0 K_H(D_\alpha) = 4K_H(D_\alpha)$, where $K_H(D_\alpha) \in \mathbb{C}$ equals the tensor depicted in Figure 5.13(a).

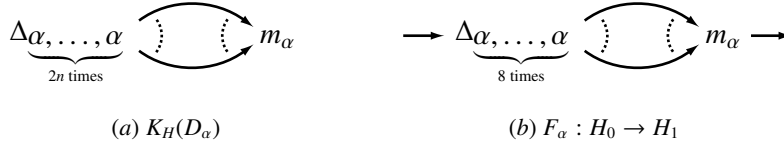

FIGURE 5.13.

Let $F_\alpha : H_0 \rightarrow H_1$ be the map defined in Figure 5.13(b). We verify in Appendix B that $F_\alpha(x) = \varepsilon(x) 1_\alpha$ for all $x \in H_\alpha$. Then, using the (co)-associativity of a (co)-multiplication, we get the equalities of Figure 5.14. Therefore $K_H(L(2(n+4), 1), f_{n+4}^k) = K_H(L(2n, 1), f_n^k)$ for any $n \geq 1$.

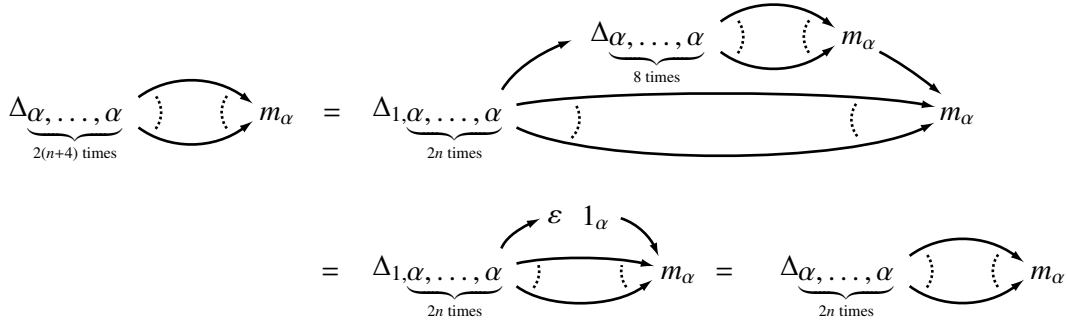

FIGURE 5.14.

Hence, by using the computations performed in Appendix B, we obtain the table of Figure 5.15. This example shows that the invariant K_H constructed in the previous section is not trivial.

	$n \equiv 0 \pmod 4$	$n \equiv 1 \pmod 4$	$n \equiv 2 \pmod 4$	$n \equiv 3 \pmod 4$
$K_H(L(2n, 1), f_n^0)$	64	64	64	64
$K_H(L(2n, 1), f_n^1)$	64	32	0	32

FIGURE 5.15.

Appendix A

In this appendix, we give some results concerning the Hopf $(\frac{1}{N}\mathbb{Z})/\mathbb{Z}$ -coalgebra $A = \{A_\alpha\}_{\alpha \in (\frac{1}{N}\mathbb{Z})/\mathbb{Z}}$ of Example 2.19. They are used for topological purpose in Section 4.13.

Fix $N \geq 1$ and $r \geq 2$ and set $t = \exp(\frac{i\pi}{2r})$ and $q = t^2 = \exp(\frac{i\pi}{r})$. Recall (see Example 2.19) that, for any $\alpha \in (\frac{1}{N}\mathbb{Z})/\mathbb{Z}$, A_α is the associative algebra over \mathbb{C} with generators $a^{\frac{1}{N}}$, e , and f , subject to the following relations:

$$\begin{aligned} a^{\frac{1}{N}}e &= q^{\frac{1}{N}}ea^{\frac{1}{N}} & a^{\frac{1}{N}}f &= q^{-\frac{1}{N}}fa^{\frac{1}{N}} & ef - fe &= \frac{a^2 - a^{-2}}{q - q^{-1}} \\ e^r &= 0 & f^r &= 0 & a^{4r} &= t^{-4r\alpha}. \end{aligned}$$

The family $A = \{A_\alpha\}_{\alpha \in \pi}$ is a Hopf π -coalgebra by setting:

$$\begin{aligned} \Delta_{\alpha,\beta}(a^{\frac{1}{N}}) &= a^{\frac{1}{N}} \otimes a^{\frac{1}{N}} & \Delta_{\alpha,\beta}(e) &= e \otimes a^{-1} + a \otimes e & \Delta_{\alpha,\beta}(f) &= f \otimes a^{-1} + a \otimes f \\ \epsilon(a) &= 1 & \epsilon(e) &= 0 & \epsilon(f) &= 0 \\ S_\alpha(a^{\frac{1}{N}}) &= a^{-\frac{1}{N}} & S_\alpha(e) &= -q^{-1}e & S_\alpha(f) &= -qf. \end{aligned}$$

When $A = \{A_\alpha\}_{\alpha \in (\frac{1}{N}\mathbb{Z})/\mathbb{Z}}$ is endowed with the trivial crossing (that is, $\varphi_\beta|_{A_\alpha} = \text{id}_{A_\alpha}$), it is a ribbon Hopf $(\frac{1}{N}\mathbb{Z})/\mathbb{Z}$ -coalgebra with R -matrix

$$R_{\alpha,\beta} = \frac{1}{4r} \sum_{n=0}^{r-1} \sum_{k,l \in \mathbb{Z}/4r\mathbb{Z}} \frac{(q - q^{-1})^n}{[n]!} t^{-(l+\alpha)n + (k-\beta)(l+\alpha-n) - n} f^n a^{k-\beta} \otimes e^n a^{-(l+\alpha)}$$

and twist $\theta_\alpha = a^{2(r-1)}u_\alpha^{-1}$, where the u_α are the Drinfeld elements of A .

Note that $\{a^m e^k f^l \mid 0 \leq k, l < r, m \in \frac{1}{N}\mathbb{Z}, 0 \leq m < 4r\}$ is a basis for A_α .

LEMMA A.1. For any $\alpha \in (\frac{1}{N}\mathbb{Z})/\mathbb{Z}$, set $\lambda_\alpha = \overline{a^{2(r-1)}e^{r-1}f^{r-1}}$, where the bar over the expression denotes the characteristic function of this element of the algebra A_α . Then $(\lambda_\alpha)_{\alpha \in (\frac{1}{N}\mathbb{Z})/\mathbb{Z}}$ is a right $(\frac{1}{N}\mathbb{Z})/\mathbb{Z}$ -integral for A .

Proof. We first recall that, if x, y are elements of an associative \mathbb{C} -algebra such that $yx = wxy$ for some $w \in \mathbb{C} \setminus \{1\}$, then, for any $n \geq 1$,

$$(A.1) \quad (x + y)^n = \sum_{k=0}^n \begin{bmatrix} n \\ k \end{bmatrix}_w x^{n-k} y^k, \text{ where } [n]_w = \frac{w^n - 1}{w - 1} \text{ and } \begin{bmatrix} n \\ k \end{bmatrix}_w = \frac{[n]_w!}{[k]_w! [n-k]_w!}.$$

Fix $0 \leq k, l < r$ and $m \in \frac{1}{N}\mathbb{Z}$ with $0 \leq m < 4r$. For any $\alpha, \beta \in \pi$, using (1.4) and (A.1), we have

$$\Delta_{\alpha,\beta}(e^k) = (e \otimes a^{-1} + a \otimes e)^k = \sum_{i=0}^k \begin{bmatrix} k \\ i \end{bmatrix}_{q^2} (e \otimes a^{-1})^{k-i} (a \otimes e)^i = \sum_{i=0}^k \begin{bmatrix} k \\ i \end{bmatrix}_{q^2} e^{k-i} a^i \otimes a^{i-k} e^i$$

and

$$\Delta_{\alpha,\beta}(f^l) = (a \otimes f + f \otimes a^{-1})^l = \sum_{j=0}^l \begin{bmatrix} l \\ j \end{bmatrix}_{q^2} (a \otimes f)^{l-j} (f \otimes a^{-1})^j = \sum_{j=0}^l \begin{bmatrix} l \\ j \end{bmatrix}_{q^2} a^{l-j} f^j \otimes f^{l-j} a^{-j}.$$

Therefore

$$\begin{aligned}\Delta_{\alpha,\beta}(a^m e^k f^l) &= \sum_{i=0}^k \sum_{j=0}^l \begin{bmatrix} k \\ i \end{bmatrix}_{q^2} \begin{bmatrix} l \\ j \end{bmatrix}_{q^2} a^m e^{k-i} a^{i+l-j} f^j \otimes a^{m+i-k} e^i f^{l-j} a^{-j} \\ &= \sum_{i=0}^k \sum_{j=0}^l \begin{bmatrix} k \\ i \end{bmatrix}_{q^2} \begin{bmatrix} l \\ j \end{bmatrix}_{q^2} q^{-(k-i)(i+l-j)-j(l-j)+ij} a^{m+i+l-j} e^{k-i} f^j \otimes a^{m+i-k-j} e^i f^{l-j}.\end{aligned}$$

Since $0 \leq j \leq l \leq r-1$ and $0 \leq k-i \leq k \leq r-1$, a necessary condition for $\lambda_\alpha(a^{m+i+l-j} e^{k-i} f^j) = \frac{1}{(a^{2(r-1)} e^{r-1} f^{r-1})} (a^{m+i+l-j} e^{k-i} f^j)$ to be non-zero is that $j = l = r-1$, $k = r-1$ and $i = 0$, and so $m = 2(r-1)$. Thus $(\lambda_\alpha \otimes \text{id}_{A_\beta}) \Delta_{\alpha,\beta}(a^m e^k f^l)$ equals $a^{2(r-1)+0-(r-1)-(r-1)} e^0 f^{(r-1)-(r-1)} = 1_\beta$ if $m = 2(r-1)$, $k = r-1$, and $l = r-1$ and equals 0 otherwise. Hence $(\lambda_\alpha \otimes \text{id}_{A_\beta}) \Delta_{\alpha,\beta}(a^m e^k f^l) = \lambda_{\alpha\beta}(a^m e^k f^l) 1_\beta$ and so $(\lambda_\alpha)_{\alpha \in (\frac{1}{N}\mathbb{Z})/\mathbb{Z}}$ is a right $(\frac{1}{N}\mathbb{Z})/\mathbb{Z}$ -integral for A . \square

We fix $\alpha \in (\frac{1}{N}\mathbb{Z})/\mathbb{Z}$ and denote by c the unique element of $\frac{1}{N}\mathbb{Z} \cap [0, 1[$ such that $\alpha \equiv c \pmod{1}$. For any $i \in \mathbb{Z}/4r\mathbb{Z}$, we set

$$\Lambda_i^\alpha = \frac{1}{4r} \sum_{j \in \mathbb{Z}/4r\mathbb{Z}} t^{(i+c)j} a^j \in A_\alpha.$$

LEMMA A.2. *In A_α , we have that $a^n = \sum_{i \in \mathbb{Z}/4r\mathbb{Z}} t^{-n(c+i)} \Lambda_i^\alpha$ for any $n \in \mathbb{Z}$.*

Proof. Let $n \in \mathbb{Z}$. Write $n = 4rq + p$ where $q, p \in \mathbb{Z}$ and $0 \leq p < 4r$. Then

$$\begin{aligned}\sum_{i \in \mathbb{Z}/4r\mathbb{Z}} t^{-n(c+i)} \Lambda_i^\alpha &= \frac{1}{4r} \sum_{i, j \in \mathbb{Z}/4r\mathbb{Z}} t^{-n(c+i)} t^{(i+c)j} a^j \\ &= \sum_{j=0}^{4r-1} \left(\frac{1}{4r} \sum_{i=0}^{4r-1} t^{(j-p)i} \right) t^{-4rqc} t^{(j-p)c} a^j \quad \text{since } t^{-4rqi} = 1 \\ &= t^{-4rqc} \sum_{j=0}^{4r-1} \delta_{j,p} t^{(j-p)c} a^j \\ &= t^{-4rqc} a^p = a^n \quad \text{since } a^{4r} = t^{-4rc}.\end{aligned}$$

\square

By Lemma A.2 and the fact that $\Lambda_i^\alpha \Lambda_j^\alpha = \delta_{i,j} \Lambda_i^\alpha$, where $\delta_{i,j}$ is the Kronecker symbol, we obtain that the set $\{\Lambda_i^\alpha \mid i \in \mathbb{Z}/4r\mathbb{Z}\}$ forms a basis of orthogonal idempotents for the algebra $\mathbb{C}\langle a \rangle \subset A_\alpha$.

LEMMA A.3. $\theta_\alpha = t^{-c^2} \Gamma_\alpha a^{2(r-1)-2c} \sum_{n=0}^{r-1} \frac{(q-q^{-1})^n}{[n]!} t^{n^2+3n} a^{-2n} e^n f^n$, where $\Gamma_\alpha = \sum_{j \in \mathbb{Z}/4r\mathbb{Z}} t^{j^2} \Lambda_j^\alpha$.

Proof. Recall that $\alpha \equiv c \pmod{1}$. By Lemma 2.5(a), we have

$$\begin{aligned}u_\alpha^{-1} &= m_\alpha(\text{id}_{H_\alpha} \otimes S_{-\alpha} S_\alpha) \sigma_{\alpha,\alpha}(R_{\alpha,\alpha}) \\ &= \frac{1}{4r} \sum_{n=0}^{r-1} \sum_{k,l \in \mathbb{Z}/4r\mathbb{Z}} \frac{(q-q^{-1})^n}{[n]!} t^{-(l+\alpha)n+(k-\alpha)(l+\alpha-n)-n} e^n a^{-(l+\alpha)} S_{-\alpha} S_\alpha(f^n a^{k-\alpha}) \\ &= \frac{1}{4r} \sum_{n=0}^{r-1} \sum_{k,l \in \mathbb{Z}/4r\mathbb{Z}} \frac{(q-q^{-1})^n}{[n]!} t^{-(l+\alpha)n+(k-\alpha)(l+\alpha-n)+3n} e^n a^{-(l+\alpha)} f^n a^{k-\alpha}\end{aligned}$$

$$\begin{aligned}
&= \frac{1}{4r} \sum_{n=0}^{r-1} \sum_{k,l \in \mathbb{Z}/4r\mathbb{Z}} \frac{(q - q^{-1})^n}{[n]!} t^{(l+\alpha)n + (k-\alpha)(l+\alpha-n) + 3n} a^{k-l-2\alpha} e^n f^n \\
&\quad (j = l - n, i = k - l + 2n) \\
&= \frac{1}{4r} \sum_{n=0}^{r-1} \sum_{i,j \in \mathbb{Z}/4r\mathbb{Z}} \frac{(q - q^{-1})^n}{[n]!} t^{j^2 + n^2 + 3n - \alpha^2 + i(j+\alpha)} a^{i-2n-2\alpha} e^n f^n \\
&= \sum_{n=0}^{r-1} \frac{(q - q^{-1})^n}{[n]!} t^{n^2 + 3n - c^2} \sum_{j \in \mathbb{Z}/4r\mathbb{Z}} t^{j^2} \left(\frac{1}{4r} \sum_{i \in \mathbb{Z}/4r\mathbb{Z}} t^{(j+c)i} a^i \right) a^{-2n-2c} e^n f^n \\
&= \sum_{n=0}^{r-1} \frac{(q - q^{-1})^n}{[n]!} t^{n^2 + 3n - c^2} \left(\sum_{j \in \mathbb{Z}/4r\mathbb{Z}} t^{j^2} \Lambda_j^\alpha \right) a^{-2n-2c} e^n f^n \\
&= t^{-c^2} \Gamma_\alpha a^{-2c} \sum_{n=0}^{r-1} \frac{(q - q^{-1})^n}{[n]!} t^{n^2 + 3n} a^{-2n} e^n f^n.
\end{aligned}$$

We conclude by using the fact that $\theta_\alpha = a^{2(r-1)} u_\alpha^{-1}$. \square

LEMMA A.4. Suppose that $r = 2$. Let $\alpha \in (\frac{1}{N}\mathbb{Z})/\mathbb{Z}$ and $p \geq 1$ with $p\alpha = 0$. Then

$$\lambda_\alpha(\theta_\alpha^p) = \begin{cases} -\frac{ip}{2} & \text{if } \alpha = 0, \\ 0 & \text{otherwise.} \end{cases}$$

Proof. Note that $q = \exp(\frac{i\pi}{2}) = i$. Recall that $\alpha = c + \mathbb{Z}$. Since $p\alpha = 0$, we have that $pc \in \mathbb{Z}$. By Lemma A.3, we have

$$\theta_\alpha = t^{-c^2} \Gamma_\alpha a^{2-2c} (1 + (i - i^{-1})t^4 a^{-2} ef) = t^{-c^2} \Gamma_\alpha a^{2-2c} (1 - 2ia^{-4}X),$$

where $X = a^2 ef$. Note that $aX = Xa$. Since

$$X^2 = a^2 ef a^2 ef = a^4 ef ef = a^4 e (ef - \frac{a^2 - a^{-2}}{i - i^{-1}}) f = \frac{1}{-2i} (-a^6 ef + a^2 ef) = \frac{1}{-2i} (1 - a^4)X,$$

and so $X^n = \frac{(1-a^4)^{n-1}}{(-2i)^{n-1}} X$ for any $n \geq 1$, we obtain that

$$\begin{aligned}
\theta_\alpha^p &= t^{-pc^2} \Gamma_\alpha^p a^{2p-2pc} (1 - 2ia^{-4}X)^p \\
&= t^{-pc^2} \Gamma_\alpha^p a^{2p-2pc} \left(1 + \sum_{n=1}^p \binom{p}{n} (-2i)^n a^{-4n} X^n \right) \\
&= t^{-pc^2} \Gamma_\alpha^p a^{2p-2pc} \left(1 + \sum_{n=1}^p \binom{p}{n} (-2i)^n a^{-4n} \frac{(1-a^4)^{n-1}}{(-2i)^{n-1}} X \right) \\
&= U_\alpha + V_\alpha X,
\end{aligned}$$

where

$$U_\alpha = t^{-pc^2} \Gamma_\alpha^p a^{2p-2pc} \in \mathbb{C}\langle a \rangle \quad \text{and} \quad V_\alpha = -2i t^{-pc^2} \Gamma_\alpha^p a^{2p-2pc} \sum_{n=1}^p \binom{p}{n} a^{-4n} (1-a^4)^{n-1} \in \mathbb{C}\langle a \rangle.$$

Since $\{\Lambda_j^\alpha \mid j \in \mathbb{Z}/8\mathbb{Z}\}$ is a set of orthogonal idempotents and by using Lemma A.2, we have

$$\Gamma_\alpha^p = \left(\sum_{j \in \mathbb{Z}/8\mathbb{Z}} t^{j^2} \Lambda_j^\alpha \right)^p = \sum_{j \in \mathbb{Z}/8\mathbb{Z}} t^{pj^2} \Lambda_j^\alpha,$$

$$a^{2p-2pc} = \sum_{j \in \mathbb{Z}/8\mathbb{Z}} t^{-(2p-2pc)(c+j)} \Lambda_j^\alpha,$$

$$a^{-4n} = \sum_{j \in \mathbb{Z}/8\mathbb{Z}} t^{4n(c+j)} \Lambda_j^\alpha,$$

and

$$(1 - a^4)^{n-1} = \left(\sum_{j \in \mathbb{Z}/8\mathbb{Z}} (1 - t^{-4(c+j)}) \Lambda_j^\alpha \right)^{n-1} = \sum_{j \in \mathbb{Z}/8\mathbb{Z}} (1 - t^{-4(c+j)})^{n-1} \Lambda_j^\alpha.$$

Therefore

$$(A.2) \quad \begin{aligned} V_\alpha &= -2i t^{-pc^2} \sum_{n=1}^p \sum_{j \in \mathbb{Z}/8\mathbb{Z}} \binom{p}{n} t^{pj^2 - (2p-2pc)(c+j) + 4n(c+j)} (1 - t^{-4(c+j)})^{n-1} \Lambda_j^\alpha \\ &= -2i t^{pc^2 - 2pc} \sum_{n=1}^p \sum_{j \in \mathbb{Z}/8\mathbb{Z}} \binom{p}{n} t^{pj^2 - (2p-2pc)j + 4n(c+j)} (1 - t^{-4(c+j)})^{n-1} \Lambda_j^\alpha \end{aligned}$$

Remark that if we write $V_\alpha = \sum_{j \in \mathbb{Z}/8\mathbb{Z}} v_j \Lambda_j^\alpha$ with $v_j \in \mathbb{C}$, then

$$\begin{aligned} \lambda_\alpha(\theta_\alpha^p) &= \lambda_\alpha(U_\alpha) + \lambda_\alpha(V_\alpha X) \\ &= 0 + \sum_{j \in \mathbb{Z}/8\mathbb{Z}} v_j \lambda_\alpha(\Lambda_j^\alpha X) \quad \text{since } U_\alpha \in \mathbb{C}\langle a \rangle \\ &= \sum_{j \in \mathbb{Z}/8\mathbb{Z}} v_j \lambda_\alpha\left(\frac{1}{8} \sum_{k \in \mathbb{Z}/8\mathbb{Z}} t^{(j+c)k} a^k X\right) \\ &= \frac{1}{8} \sum_{j, k \in \mathbb{Z}/8\mathbb{Z}} v_j t^{(j+c)k} \overline{(a^2 e f)} (a^{k+2} e f) \\ &= \frac{1}{8} \sum_{j \in \mathbb{Z}/8\mathbb{Z}} v_j. \end{aligned}$$

Hence, using (A.2),

$$\begin{aligned} \lambda_\alpha(\theta_\alpha^p) &= -\frac{i}{4} t^{pc^2 - 2pc} \sum_{j \in \mathbb{Z}/8\mathbb{Z}} \sum_{n=1}^p \binom{p}{n} t^{pj^2 - (2p-2pc)j + 4n(c+j)} (1 - t^{-4(c+j)})^{n-1} \\ &= -\frac{i}{4} t^{pc^2 - 2pc} \sum_{j \in \mathbb{Z}/8\mathbb{Z}} t^{pj^2 - (2p-2pc)j} \sum_{n=1}^p \binom{p}{n} (t^{4(c+j)})^n (1 - t^{-4(c+j)})^{n-1}. \end{aligned}$$

If $\alpha = 0$ (that is, $c = 0$), then

$$\begin{aligned} \lambda_0(\theta_0^p) &= -\frac{i}{4} \sum_{j \in \mathbb{Z}/8\mathbb{Z}} t^{pj^2 - 2pj} \sum_{n=1}^p \binom{p}{n} (-1)^{jn} (1 - (-1)^j)^{n-1} \\ &= -\frac{i}{4} \left(\sum_{j \in \mathbb{Z}/8\mathbb{Z}, j \text{ even}} t^{pj^2 - 2pj} \sum_{n=1}^p \binom{p}{n} 0^{n-1} + \sum_{j \in \mathbb{Z}/8\mathbb{Z}, j \text{ odd}} t^{pj^2 - 2pj} \sum_{n=1}^p \binom{p}{n} (-1)^n 2^{n-1} \right) \\ &= -\frac{i}{8} \left(\sum_{j \in \mathbb{Z}/8\mathbb{Z}, j \text{ even}} t^{pj^2 - 2pj} p + \sum_{j \in \mathbb{Z}/8\mathbb{Z}, j \text{ odd}} t^{pj^2 - 2pj} \sum_{n=1}^p \binom{p}{n} (-2)^n \right) \\ &= -\frac{i}{8} \left(p \sum_{j \in \mathbb{Z}/8\mathbb{Z}, j \text{ even}} t^{pj^2 - 2pj} + ((-1)^p - 1) \sum_{j \in \mathbb{Z}/8\mathbb{Z}, j \text{ odd}} t^{pj^2 - 2pj} \right) \end{aligned}$$

$$\begin{aligned}
&= -\frac{i}{8} \left(p(1 + 1 + t^{8p} + t^{24p}) + ((-1)^p - 1)(t^{-p} + t^{3p} + t^{15p} + t^{35p}) \right) \\
&= -\frac{i}{8} \left(4p + 2t^{-p}((-1)^p - 1)(1 + (-1)^p) \right) \\
&= -\frac{ip}{2}.
\end{aligned}$$

Suppose that $\alpha \neq 0$ (that is, $c \neq 0$). For any $j \in \mathbb{Z}/8\mathbb{Z}$, set $x_j = t^{-4(c+j)} = (-1)^j \exp(-i\pi c) \neq \pm 1$. Then

$$\begin{aligned}
\sum_{n=1}^p \binom{p}{n} (t^{4(c+j)})^n (1 - t^{-4(c+j)})^{n-1} &= \sum_{n=1}^p \binom{p}{n} x_j^{-n} (1 - x_j)^{n-1} \\
&= x_j^{-p} (1 - x_j)^{-1} \sum_{n=1}^p \binom{p}{n} (x_j)^{p-n} (1 - x_j)^n \\
&= x_j^{-p} (1 - x_j)^{-1} (1^p - x_j^p) \\
&= -\frac{1 - x_j^{-p}}{1 - x_j}.
\end{aligned}$$

Hence

$$\begin{aligned}
\lambda_\alpha(\theta_\alpha^p) &= \frac{i}{4} t^{pc^2-2pc} \sum_{j \in \mathbb{Z}/8\mathbb{Z}} t^{pj^2-(2p-2pc)j} \frac{1 - x_j^{-p}}{1 - x_j} \\
&= \frac{i}{4} t^{pc^2-2pc} \left(\frac{1 - x_0^{-p}}{1 - x_0} \sum_{j \in \mathbb{Z}/8\mathbb{Z}, j \text{ even}} t^{pj^2-(2p-2pc)j} + \frac{1 - (-x_0)^{-p}}{1 + x_0} \sum_{j \in \mathbb{Z}/8\mathbb{Z}, j \text{ odd}} t^{pj^2-(2p-2pc)j} \right) \\
&= \frac{i}{4} t^{pc^2-2pc} \left(\frac{1 - x_0^{-p}}{1 - x_0} (1 + t^{4pc} + t^{8p+8pc} + t^{24p+12pc}) \right. \\
&\quad \left. + \frac{1 - (-x_0)^{-p}}{1 + x_0} (t^{-p+2pc} + t^{3p+6pc} + t^{15p+10pc} + t^{35p+14pc}) \right) \\
&= \frac{i}{2} t^{pc^2-2pc} \left(\frac{1 - x_0^{-p}}{1 - x_0} (1 + x_0^{-p}) + \frac{1 - (-x_0)^{-p}}{1 + x_0} t^{-p+2pc} (1 + (-x_0)^{-p}) \right) \\
&= \frac{i}{2} t^{pc^2-2pc} \left(\frac{1 - x_0^{-2p}}{1 - x_0} + t^{-p+2pc} \frac{1 - x_0^{-2p}}{1 + x_0} \right) \\
&= 0 \quad \text{since } pc \in \mathbb{Z} \text{ and so } x_0^{-2p} = \exp(2i\pi pc) = 1.
\end{aligned}$$

This completes the proof of the lemma. \square

Appendix B

In this appendix, we use the software Maple 6 (under a Dell Inspiron 8000 with Prentium III) to give some computations used in Section 5.3. These computations concern the finite type involutory Hopf $\mathbb{Z}/2\mathbb{Z}$ -coalgebra $H = \{H_0, H_1\}$ over \mathbb{C} of Example 2.18.

Recall that $\{e_1, e_2, e_3, e_4\}$ is the (standard) basis of $H_0 = \mathbb{C} \oplus \mathbb{C} \oplus \mathbb{C} \oplus \mathbb{C}$ and $\{e_{1,1}, e_{1,2}, e_{2,1}, e_{2,2}\}$ is the (standard) basis of $H_1 = \text{Mat}_2(\mathbb{C})$. To simplify the notations, we set $f_1 = e_{1,1}$, $f_2 = e_{2,2}$, $f_3 = e_{2,1}$, and $f_4 = e_{1,2}$.

We first define two arrays m and d which memorize the structure constants of the products of H_0 and H_1 and of the comultiplication $\Delta = \{\Delta_{0,0}, \Delta_{0,1}, \Delta_{1,0}, \Delta_{1,1}\}$ of H . They are defined, for any $1 \leq i, j, k \leq 4$, by

$$\begin{aligned} m[0, i, j, k] &= \langle e_k^*, e_i \cdot e_j \rangle & m[1, i, j, k] &= \langle f_k^*, f_i \cdot f_j \rangle \\ d[0, 0, i, j, k] &= \langle e_j^* \otimes e_k^*, \Delta_{0,0}(e_i) \rangle & d[0, 1, i, j, k] &= \langle e_j^* \otimes f_k^*, \Delta_{0,1}(f_i) \rangle \\ d[1, 0, i, j, k] &= \langle f_j^* \otimes e_k^*, \Delta_{1,0}(f_i) \rangle & d[1, 1, i, j, k] &= \langle f_j^* \otimes f_k^*, \Delta_{1,1}(e_i) \rangle \end{aligned}$$

where \langle, \rangle denotes the usual pairing between a \mathbb{k} -space and its dual.

```

> delta := (x,y) -> if (x=y) then 1 else 0 fi;
    delta := proc(x, y) option operator, arrow; if x = y then 1 else 0 end if end proc
> m:= array(0..1,1..4,1..4,1..4);
    m := array(0..1, 1..4, 1..4, 1..4, [])
> for i to 4 do for j to 4 do for k to 4 do
> m[0,i,j,k]:=delta(i,j)*delta(j,k) od od od;
> e:= (x,y) -> if (x=1) then if (y=1) then 1 else 3 fi else if (y=1)
> then 4 else 2 fi fi;
    e := proc(x, y)
    option operator, arrow;
    if x = 1 then if y = 1 then 1 else 3 end if else if y = 1 then 4 else 2 end if end if
    end proc
> for i to 2 do for j to 2 do for k to 2 do
> for l to 2 do for u to 2 do for v to 2 do
> m[1,e(i,j),e(k,l),e(u,v)]:=delta(i,u) *delta(j,k)*delta(l,v)
> od od od od od od;
> d:=array(0..1,0..1,1..4,1..4,1..4);
    d := array(0..1, 0..1, 1..4, 1..4, 1..4, [])
> for i from 0 to 1 do for j from 0 to 1 do for k to 4 do
> for l to 4 do for x to 4 do d[i,j,k,l,x]:=0 od od od od od;
> d[0,0,1,1,1]:=1:          d[0,0,1,2,2]:=1:
> d[0,0,1,3,3]:=1:          d[0,0,1,4,4]:=1:
> d[0,0,2,1,2]:=1:          d[0,0,2,2,1]:=1:

```

```

> d[0,0,2,3,4]:=1:          d[0,0,2,4,3]:=1:
> d[0,0,3,1,3]:=1:          d[0,0,3,2,4]:=1:
> d[0,0,3,3,1]:=1:          d[0,0,3,4,2]:=1:
> d[0,0,4,1,4]:=1:          d[0,0,4,2,3]:=1:
> d[0,0,4,3,2]:=1:          d[0,0,4,4,1]:=1:
> d[1,1,1,1,1]:=1/2:        d[1,1,1,2,2]:=1/2:
> d[1,1,1,3,3]:=1/2:        d[1,1,1,4,4]:=1/2:
> d[1,1,2,1,2]:=1/2:        d[1,1,2,2,1]:=1/2:
> d[1,1,2,3,4]:=I/2:        d[1,1,2,4,3]:=-I/2:
> d[1,1,3,1,1]:=1/2:        d[1,1,3,2,2]:=1/2:
> d[1,1,3,3,3]:=-1/2:       d[1,1,3,4,4]:=-1/2:
> d[1,1,4,1,2]:=1/2:        d[1,1,4,2,1]:=1/2:
> d[1,1,4,3,4]:=-I/2:       d[1,1,4,4,3]:=I/2:
> d[1,0,1,1,1]:=1:          d[1,0,1,2,2]:=1:
> d[1,0,1,1,3]:=1:          d[1,0,1,2,4]:=1:
> d[1,0,2,3,1]:=1:          d[1,0,2,4,2]:=I:
> d[1,0,2,3,3]:=-1:         d[1,0,2,4,4]:=-I:
> d[1,0,3,4,1]:=1:          d[1,0,3,3,2]:=-I:
> d[1,0,3,4,3]:=-1:         d[1,0,3,3,4]:=I:
> d[1,0,4,2,1]:=1:          d[1,0,4,1,2]:=1:
> d[1,0,4,2,3]:=1:          d[1,0,4,1,4]:=1:
> d[0,1,1,1,1]:=1:          d[0,1,1,2,2]:=1:
> d[0,1,1,3,1]:=1:          d[0,1,1,4,2]:=1:
> d[0,1,2,1,3]:=1:          d[0,1,2,2,4]:=-I:
> d[0,1,2,3,3]:=-1:         d[0,1,2,4,4]:=I:
> d[0,1,3,1,4]:=1:          d[0,1,3,2,3]:=I:
> d[0,1,3,3,4]:=-1:         d[0,1,3,4,3]:=-I:
> d[0,1,4,1,2]:=1:          d[0,1,4,2,1]:=1:
> d[0,1,4,3,2]:=1:          d[0,1,4,4,1]:=1:

```

The procedure `proc(a,n,in1,in2)` allows to compute the following scalar

$$e_{in1} \longrightarrow \underbrace{\Delta a, \dots, a}_{2n \text{ times}} \begin{array}{c} \curvearrowright \\ \curvearrowleft \end{array} m_a \longrightarrow x,$$

where $x = e_{in2}$ if $a = 0$ and $x = f_{in2}$ if $a = 1$.

```

> rec:=proc(a,n,in1,in2) local i1,i2,i3,i4; else
> if n=1 then sum(sum(d[a,a,in1,i1,i2]*m[a,i1,i2,in2],i1=1..4), i2=1..4)
> sum(sum(sum(sum(d[0,0,in1,i1,i2]*rec(a,n-1,i2,i4)*rec(a,1,i1,i3)
> *m[a,i3,i4,in2],i4=1..4),i3=1..4),i2=1..4),i1=1..4) fi end;

```

```

rec := proc(a, n, in1, in2)

```

```

local i1, i2, i3, i4;

```

```

if n = 1 then sum(sum( $d_{a,a,in1,i1,i2} * m_{a,i1,i2,in2}$ , i1 = 1..4), i2 = 1..4)

```

```

else sum(sum(sum(sum(

```

```

 $d_{0,0,in1,i1,i2} * rec(a, n - 1, i2, i4) * rec(a, 1, i1, i3) * m_{a,i3,i4,in2}$ ,

```

```

i4 = 1..4), i3 = 1..4), i2 = 1..4), i1 = 1..4)

```

```

end if

```

```

end proc

```

For any $1 \leq i, j \leq 4$, let us set $F(0, i, j) = \langle e_j^*, \varepsilon(e_i)1_0 \rangle$ and $F(1, i, j) = \langle f_j^*, \varepsilon(e_i)1_1 \rangle$.

- > F:=proc(c, jn1, jn2) if (c=0) then delta(jn1,1) else
- > delta(jn1,1)*(delta(jn2,1)+delta(jn2,2)) fi end;

```

F := proc(c, jn1, jn2)
      if c = 0 then  $\delta(jn1, 1)$  else  $\delta(jn1, 1) * (\delta(jn2, 1) + \delta(jn2, 2))$  end if
end proc

```

The procedure F allows us to verify that $F_\alpha(x) = \varepsilon(x)1_\alpha$ for any $\alpha \in \mathbb{Z}/2\mathbb{Z}$ and $x \in H_\alpha$, where F_α is defined as in Section 5.3.

- > difference:=0;
- difference := 0*
- > for k from 0 to 1 do for i to 4 do for j to 4 do
- > difference:=difference+ abs(rec(k,4,i,j)-F(k,i,j)) od od od;
- > difference;

0

Finally the function $\text{inv}(n, a)$ gives the value of $K_H(L(2n, 1), f_n^a)$.

- > inv:=(n, a) -> 4* sum(sum(sum(sum(
- > d[0,0,'j1','j1','j2']*rec(a,n,'j2','j3')*m[a,'j3','j4','j4'],
- > 'j1'=1..4), 'j2'=1..4), 'j3'=1..4), 'j4'=1..4);

inv := (n, a) → 4

$$\left(\sum_{j_4'=1}^4 \left(\sum_{j_3'=1}^4 \left(\sum_{j_2'=1}^4 \left(\sum_{j_1'=1}^4 d_{0,0,'j_1','j_1','j_2'} \text{rec}(a, n, 'j_2', 'j_3') m_{a,'j_3','j_4','j_4'} \right) \right) \right) \right)$$

- > inv(1,0); inv(1,1);

64

32

- > inv(2,0); inv(2,1);

64

0

- > inv(3,0); inv(3,1);

64

32

- > inv(4,0); inv(4,1);

64

64

Bibliography

- [1] E. Abe, *Hopf algebras*, Cambridge University Press, Cambridge, 1980.
- [2] J. W. Barrett and B. W. Westbury, *The equality of 3-manifold invariants*, Math. Proc. Cambridge Philos. Soc. **118** (1995), no. 3, 503–510.
- [3] C. Blanchet, N. Habegger, G. Masbaum, and P. Vogel, *Three-manifold invariants derived from the Kauffman bracket*, Topology **31** (1992), no. 4, 685–699.
- [4] ———, *Topological quantum field theories derived from the Kauffman bracket*, Topology **34** (1995), no. 4, 883–927.
- [5] A. Bruguières, *Catégories prémodulaires, modularisations et invariants des variétés de dimension 3*, Math. Annalen **316** (2000), no. 2, 215–236.
- [6] G. Burde and H. Zieschang, *Knots*, Walter de Gruyter & Co., Berlin, 1985.
- [7] V. G. Drinfeld, *Quantum groups*, Proc. I.C.M. Berkeley 1986, Vol. 1, 2 (Berkeley, Calif., 1986) (Providence, RI), Amer. Math. Soc., 1987, pp. 798–820.
- [8] ———, *On almost cocommutative Hopf algebras*, Leningrad Math. J. **1** (1990), no. 2, 321–342.
- [9] B. Enriquez, *Private communication*, 2001.
- [10] R. Fenn and C. Rourke, *On Kirby’s calculus of links*, Topology **18** (1979), no. 1, 1–15.
- [11] W. Fulton, *Algebraic topology*, Springer-Verlag, New York, 1995.
- [12] M. A. Hennings, *Hopf algebras and regular isotopy invariants for link diagrams*, Math. Proc. Camb. Phil. Soc. **109** (1991), no. 1, 59–77.
- [13] ———, *Invariants of links and 3-manifolds obtained from Hopf algebras*, J. of London Math. Soc. **54** (1996), no. 3, 594–624.
- [14] V. F. R. Jones, *A polynomial invariant for knots via von Neumann algebras*, Bull. Amer. Math. Soc. (N.S.) **12** (1985), no. 1, 103–111.
- [15] C. Kassel, *Quantum Groups*, Springer-Verlag, Berlin, New York, 1995.
- [16] C. Kassel, M. Rosso, and V. Turaev, *Quantum groups and knot invariants*, Société Mathématique de France, Paris, 1997.
- [17] L. H. Kauffman and D. E. Radford, *Invariants of 3-manifolds derived from finite dimensional Hopf algebras*, J. of Knot Theory and its Ramifications **4** (1995), no. 1, 131–162.
- [18] T. Kerler, *Genealogy of non-perturbative quantum-invariants of 3-manifolds: the surgical family*, Geometry and physics (Aarhus, 1995), Dekker, New York, 1997, pp. 503–547.
- [19] R. Kirby, *A calculus of framed links in S^3* , Invent. Math. **45** (1978), no. 3, 35–56.
- [20] R. Kirby and P. Melvin, *The 3-manifold invariants of Witten and Reshetikhin-Turaev for $\mathfrak{sl}(2, \mathbb{C})$* , Invent. Math. **105** (1991), no. 3, 473–545.
- [21] G. Kuperberg, *Involutive Hopf algebras and 3-manifold invariants*, Internat. J. Math. **2** (1991), no. 1, 41–66.
- [22] S. Mac Lane, *Categories for the working mathematician*, second ed., Springer-Verlag, New York, 1998.
- [23] R. G. Larson and D. E. Radford, *Finite dimensional cosemisimple Hopf algebras in characteristic 0 are semisimple*, Journal of Algebra **117** (1988), no. 2, 267–289.
- [24] R. G. Larson and M. E. Sweedler, *An associative orthogonal bilinear form for Hopf algebras*, Amer. J. Math **91** (1969), 75–93.
- [25] W. B. R. Lickorish, *Three-manifolds and the Temperley-Lieb algebra*, Math. Ann. **290** (1991), no. 4, 657–670.
- [26] ———, *The skein method for three-manifold invariants*, J. Knot Theory Ramifications **2** (1993), no. 2, 171–194.
- [27] ———, *An introduction to knot theory*, Springer-Verlag, New York, 1997.
- [28] ———, *Skeins, $\mathfrak{su}(N)$ three-manifold invariants and TQFT*, Comment. Math. Helv. **75** (2000), no. 1, 45–64.
- [29] V. Lyubashenko, *Invariants of 3-manifolds and projective representations of mapping class groups via quantum groups at roots of unity*, Comm. Math. Phys. **172** (1995), no. 3, 467–516.
- [30] ———, *Tangles and Hopf algebras in braided categories*, J. Pure Appl. Algebra **98** (1995), no. 3, 245–278.
- [31] S. Majid, *Braided groups*, J. Pure Appl. Algebra **86** (1993), no. 2, 187–221.
- [32] C. Nastasescu and B. Torrecillas, *Graded coalgebras*, Tsukuba J. Math. **17** (1993), no. 2, 461–479.

- [33] W. D. Nichols and M. B. Zoeller, *Finite-dimensional Hopf algebras are free over grouplike subalgebras*, J. Pure Applied Algebra **56** (1989), no. 1, 51–57.
- [34] T. Ohtsuki, *Colored ribbon Hopf algebras and universal invariants of framed links*, J. Knot Theory and Its Rami. **2** (1993), no. 2, 211–232.
- [35] ———, *Invariants of 3-manifolds derived from universal invariants of framed links*, Math. Proc. Cambridge Philos. Soc. **117** (1995), no. 2, 259–273.
- [36] V. V. Prasolov and A. B. Sossinsky, *Knots, links, braids and 3-manifolds*, American Mathematical Society, Providence, RI, 1997.
- [37] D. E. Radford, *The order of the antipode of a finite dimensional Hopf algebra is finite*, Amer. J. Math. **98** (1976), no. 2, 333–355.
- [38] ———, *On the antipode of a quasitriangular Hopf algebra*, Journal of Algebra **151** (1992), no. 1, 1–11.
- [39] ———, *The trace function and Hopf algebras*, Journal of Algebra **163** (1994), no. 3, 583–622.
- [40] N. Yu Reshetikhin and V. G. Turaev, *Ribbon graphs and their invariants derived from quantum groups*, Comm. Math. Phys. **127** (1990), no. 1, 1–26.
- [41] ———, *Invariants of 3-manifolds via link polynomials and quantum groups*, Invent. Math. **103** (1991), no. 3, 547–597.
- [42] M. Rosso, *Représentations des groupes quantiques*, Astérisque (1991), no. 201-203, Exp. No. 744, 443–483 (1992), Séminaire Bourbaki, Vol. 1990/91.
- [43] J. Singer, *Three-dimensional manifolds and their Heegaard diagrams*, Trans. Amer. Math. Soc. **35** (1933), no. 1, 88–111.
- [44] E. H. Spanier, *Algebraic Topology*, Springer-Verlag, Berlin, New York, 19??, Corrected reprint of the 1966 original.
- [45] M. E. Sweedler, *Hopf algebras*, W.A. Benjamin, INC., New York, 1969.
- [46] ———, *Integrals for Hopf algebras*, Annals of Math. (2) **89** (1969), 323–335.
- [47] V. G. Turaev, *Quantum invariants of knots and 3-manifolds*, Walter de Gruyter & Co., Berlin, 1994.
- [48] ———, *Homotopy field theory in dimension 3 and group-categories*, preprint GT/0005291, 2000.
- [49] L. Vainerman, *Private communication*, 2001.
- [50] A. Virelizier, *Hopf group-coalgebras*, Journal of Pure and Applied Algebra, to appear.
- [51] E. Witten, *Quantum field theory and the Jones polynomial*, Comm. Math. Phys. **121** (1989), no. 3, 351–399.
- [52] M. Zunino, *Doubles quantiques des structures croisées*, in preparation.

Table of symbols

$*$ 2 1_α 2 C^{op} 51 C^* 2 C_α 2 C_n 98 $\text{Conv}(C, A)$ 2 D 97 D_L^{split} 98 F_c 107 F_α 52 G_α 35 \tilde{H} 4 H^* 4 H_α 2 H_α^{Bd} 63 H_α^{cop} 3 H_α^{op} 3 $H_\alpha^{\text{op,cop}}$ 3 H_α^φ 42 H_α^\square 11 $I_{\alpha_1, \dots, \alpha_n}$ 91 $\text{Inv}_{\{H, \text{tr}\}}$ 78 K_H 131 $K_H(D)$ 126 $K_{\alpha_1, \dots, \alpha_n}$ 91 \tilde{L}_i 74 (L, z, g) 74 $M \otimes H$ 9 (M, ξ) 88 (M, ξ, \tilde{x}) 88 (M, x, f) 89 $(M_1 \# M_2, \xi_1 \# \xi_2)$ 95 M_α 5 $\overline{M_\alpha^{\text{coH}}}$ 5 $\overline{M_\alpha}$ 6 M_l 130 M_u 130 R_g 112 R'_g 113 $R_{\alpha, \beta}$ 27 $\text{Rep}_\alpha(H)$ 49	(S, u, l) 123 S_α 2, 55 S_α^{cop} 3 $S_\alpha^{\text{op,cop}}$ 3 $S_{i,j}$ 97 (T, z, g) 106 T_α 122 T_c 107 $T_{D_L^{\text{split}}}$ 99 Tr 22 U_g 112 U'_g 113 $Z(D)$ 126 Δ_α 55 $\Delta_{\alpha, \beta}$ 2 $\Delta_{\alpha, \beta}^{\text{op,cop}}$ 3 Δ_\pm 97 Λ 10 Σ_g 113 Σ'_g 113 δ_c 108 \doteq 48 \doteq 59 \equiv 83 ε 2 ε_α 55 η 55 λ_α 10 $\lambda_{(\gamma, \nu)}$ 76 $\mathcal{T}_{(C, D)}$ 98 μ_α^{semi} 99 μ_α 56 ν 14 φ_β 25 $\widehat{\varphi}$ 26 π 2 $\psi_H(T, z, g)$ 109 ψ_ρ 6 $\rho_{\alpha, \beta}$ 5 $\sigma_{U, V}$ 2 $\sigma_{\beta, \alpha}$ 27 τ_H 89
--	--

θ_U	47
θ_α	34
$b_-(L)$	89
$c_{(1,\alpha)} \otimes c_{(2,\beta)}$	2
coev_U	45
$\widetilde{\text{coev}}_U$	47
$d : F \xrightarrow{\cdot} b$	51
$\dim_{\mathbb{q}} U$	48
ev_U	45
$\widetilde{\text{ev}}_U$	47
g_α	13
h_α	33
i_L	89
\mathbb{k}	2
\mathbb{k}^c	42
ℓ_α	32
l_i	123
m_α	2
$m_{(0,\alpha)} \otimes m_{(1,\beta)}$	5
$m_{\alpha,\beta}$	55
p_g	113
q_g	112
$r_{12\gamma}$	27
tr_α	36
$\text{tr}_{\mathbb{q}}(f)$	48
u_α	28
u_k	123
$w_i(x_1, \dots, x_g)$	123

Index

A	
antipode	2
bijective	3
B	
braiding	46
C	
category	
\mathbb{k} -linear	45
automorphism of a	46
direct sum	51
simple object of a	51
splitting as a disjoint union	45
π -category	45
braided	46
components of a	46
crossed	46
dual morphism in a	47
finitely semisimple	51
modular	97
neutral component of a	46
premodular	51
rank of a	97
ribbon	47
central injection	39
central prolongation	39
central map of a	39
crossed	40
quasitriangular	41
ribbon	42
π -coalgebra	2
cosemisimple	19
cobordism	113
π -cobordism	114
composition of	116
equivalence of	114
coend	51
cointegral	56
coinvariants	5
subcomodule of	5
π -colored link diagram	74
equivalence of	74
π -comodule	5
π -subcomodule of a	5
cosemisimple	19
direct sum of	19
morphism	5
non-zero	19
reduced	20
simple	19
structure maps of a	5
sum of	19
comultiplication	2
convolution	
algebra	2
product	2
counit	2
crossing	25
multiplicative	25
trivial	27
D	
dinatural transformation	51
component of a	51
universal	51
Drinfeld elements	28
dual π -graded algebra	2
F	
flat diagram	
algebraic decoration of a	77
component of a	77
of a π -link	77
of a π -tangle	108
of a component	77
flat fiber bundle	90
framed	
link	74
tangle	106
framing number	74
G	
generic diagram	74
graded module	6
cosemisimple	19
rational	6

- submodule of a 6
 - grouplike element
 - distinguished 14
 - π -grouplike element 13
 - distinguished 13
 - spherical 35
- H**
- Heegaard
 - splitting 130
 - surface 130
 - Heegaard diagram 123
 - π -colored 124
 - color of a 124
 - colored by a morphism 131
 - equivalence of 124
 - lower circle of a 123
 - of a 3-manifold 130
 - oriented 123
 - upper circle of a 123
 - homotopy quantum field theory 118
 - Hopf π -coalgebra
 - copposite 27, 32, 35
 - mirror 32, 35
 - opposite 27
 - Hopf π -algebra in a category 55
 - Hopf π -coalgebra 2
 - braided 63
 - copposite 3
 - crossed 25
 - involutory 22
 - mirror 27
 - of finite type 3
 - opposite 3
 - opposite and copposite 3
 - quasitriangular 27
 - ribbon 34
 - semisimple 18
 - unimodular 36
 - Hopf π -comodule 8
 - π -subcomodule of a 8
 - morphism of 8
 - trivial 9
- I**
- integral 10
 - π -integral 10
 - categorical 56
 - non-zero 10
- K**
- Kirby moves 91
- L**
- π -link 74
 - H -compatible 76
 - equivalence of 74
 - longitude 74
- M**
- π -manifold 88
 - equivalence of 88
 - pointed 88
 - mirror image 85
 - monodromy 88
- O**
- opposite category 51
- Q**
- quantum
 - dimension 48
 - trace 48
- R**
- R -matrix 27
- S**
- space
 - base 88
 - target 118
 - total 88
 - surface
 - lower 130
 - parameterized 113
 - standard 113
 - upper 130
 - π -surface 113
 - equivalence of 113
 - parameterized 113
 - system of colors of a 113
 - surgery 89
- T**
- π -tangle 106
 - associated to a π -cobordism 114
 - color of an endpoint of a 106
 - composition of 112
 - equivalence of 106
 - special 106
 - systems of colors of a 107
 - π -trace 36
 - twist
 - of a ribbon π -category 47
 - of a ribbon π -coalgebra 34

V

vertical segment 74
color of a 74

